

©Copyright Xandex Inc. All Rights Reserved.  
The information disclosed herein is deemed to be confidential, proprietary, and a trade secret of Xandex, Inc. This information may not be used, reproduced or disclosed without the express prior written consent of Xandex, Inc.

REVISIONS

REV	DESCRIPTION	CHANGE NUMBER	BY	DATE	APPROVED
B	REDRAW ON ACAD	1058	HG	12/01/95	DT
C	TITLE WAS: ...PLUS 102	1163	MD	10/29/96	DT
D	ADD NOTE 9	1568	JMc	10/17/97	

NOTES:

- FOR USE WITH PACIFIC WESTERN SYSTEMS PROBERS. CABLED PROBING APPLICATION.
- MOUNTING PLATE IS CONNECTED TO PROBER USING TWO #6-32 X 3/8 PAN HD. SCREWS (NOT SUPPLIED).
- THIS INKER USES THE DM-1 AND DM-1.25 CARTRIDGES ONLY.
- INKER ARM IS ADJUSTABLE ALONG THE "Z" AXIS BY  $\pm .187$ .
- THE MOUNTING ARM ANGLE OF APPROACH CAN BE ADJUSTED  $\pm 10^\circ$ .
- ALL DIMENSIONS SHOWN WITH ADJUSTMENTS IN NEUTRAL POSITION.
- HOLDER ALLOWS ADDITIONAL ADJUSTMENT OF "Z" AXIS BY MOVING SLIDE BRACKET.
- COMPONENTS MAY BE ORDERED SEPARATELY: INKER BASE 102 (#320-0102) AND CARTRIDGE HOLDER H1-24A7 (#310-1212). FOR 5 MIL CARTRIDGES USE HOLDER H2-24A7 (#310-2212).
- FOR 5 MIL CARTRIDGES, RETROFIT CARTRIDGE HOLDER USING PLUNGER STOP ASSEMBLY #210-0016.

FILE NAME 9000090D	ITEM QTY PART NUMBER	DESCRIPTION
APPROVALS DATE DRAWN HOLLY G. 10/23/95	INTERPRET DRAWING PER ANSI Y14.5 - 1982	 1125 N. McDOWELL BLVD. PETALUMA, CA 95954 (707) 763 7799
CHECKED	TOLERANCES UNLESS OTHERWISE SPECIFIED	
DATE ENG'G DAVE T. 4/9/96	DIMENSIONS ARE IN INCHES	TITLE INKER MODEL PWS 102 (KIT #330-2102)
REF. ENG'G	DECIMALS	DO NOT SCALE DRAWING
NEXT ASSEMBLIES.....USED ON	1 PL $\pm$ FRACTIONS $\pm$	SIZE SCALE SHEET DRAWING NUMBER REV
	2 PL $\pm$ ANGLES $\pm$	A 1/1 1 of 2 900-0090 D
	3 PL $\pm$	
	4 PL $\pm$ ALL SURFACES	

©Copyright Xandex Inc. All Rights Reserved.  
The information disclosed herein is deemed to be confidential, proprietary, and a trade secret of Xandex, Inc. This information may not be used, reproduced or disclosed without the express prior written consent of Xandex, Inc.

REVISIONS

REV	DESCRIPTION	CHANGE NUMBER	BY	DATE	APPROVED
-	SEE SHEET 1				

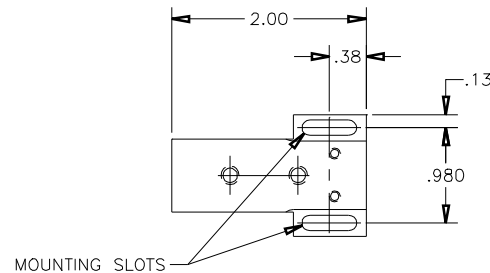
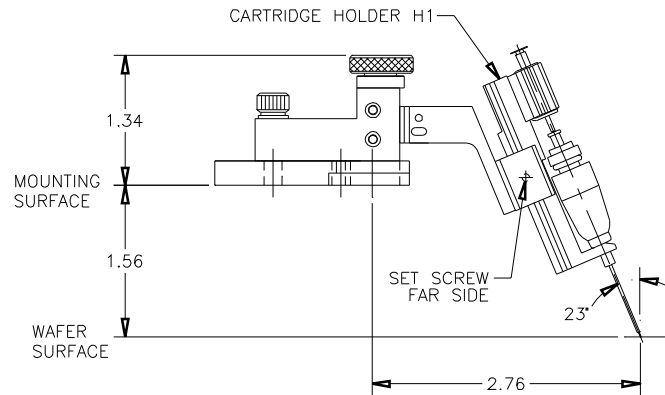

1125 N. McDOWELL BLVD.  
PETALUMA, CA 95954  
(707) 763 7799

TITLE  
INKER MODEL PWS  
(KIT #330-2102)

FILE NAME 900-0090D	DO NOT SCALE DRAWING
SIZE SCALE SHEET DRAWING NUMBER REV	A 1/1 2 of 2 900-0090 D