

©Copyright Xandex Inc., All Rights Reserved.  
The information disclosed herein is deemed to be confidential, proprietary, and a trade secret of Xandex, Inc. This information may not be used, reproduced or disclosed without the express prior written consent of Xandex, Inc.

REVISIONS					
REV	DESCRIPTION	CHANGE NUMBER	BY	DATE	APPROVED
B	REDRAW ON ACAD	1058	HG	12/01/95	DT
C	ADD NOTE 9	1568	JMc	10/17/97	

**NOTES:**

- FOR USE WITH KLA PROBER MODELS 10XX AND 12XX. CABLED PROBING APPLICATION.
- MOUNTING PLATE IS CONNECTED TO PROBER USING TWO M3-.5 METRIC SCREWS (SUPPLIED).
- THIS INKER USES THE DM-1 AND DM-1.25 CARTRIDGES ONLY.
- INKER ARM IS ADJUSTABLE ALONG THE "Z" AXIS BY  $\pm .187$ .
- THE MOUNTING ARM ANGLE OF APPROACH CAN BE ADJUSTED  $\pm 10^\circ$ .
- ALL DIMENSIONS SHOWN WITH ADJUSTMENTS IN NEUTRAL POSITION.
- HOLDER ALLOWS ADDITIONAL ADJUSTMENT OF "Z" AXIS BY MOVING SLIDE BRACKET.
- COMPONENTS MAY BE ORDERED SEPARATELY: INKER BASE 103 (#320-0103) AND CARTRIDGE HOLDER H1-24C7 (#310-1232). FOR 5 MIL CARTRIDGES USE HOLDER H2-24C7 (#310-2232).
- FOR 5 MIL CARTRIDGES, RETROFIT CARTRIDGE HOLDER USING PLUNGER STOP ASSEMBLY #210-0016.

FILE NAME	9000091C	ITEM	QTY	PART NUMBER	DESCRIPTION			
APPROVALS	DATE	INTERPRET DRAWING		<b>XANDEX</b> INC.	1125 N. McDOWELL BLVD. PETALUMA, CA 95954 (707) 763 7799			
DRAWN	10/23/95	PER ANSI Y14.5 - 1982						
CHECKED		TOLERANCES		TITLE INKER MODEL KLA 103 (KIT #330-1103)				
***		UNLESS OTHERWISE SPECIFIED						
ENGRG	DAVE T. 4/8/96	DIMENSIONS ARE IN INCHES		DO NOT SCALE DRAWING				
DRG		DECIMALS						
NEXT ASSEMBLIES.....USED ON		1 PL $\pm$	FRACTIONS $\pm$	SIZE	SCALE	SHEET	DRAWING NUMBER	REV
		2 PL $\pm$	ANGLES $\pm$	A	1/1	1 of 2	900-0091	C
		3 PL $\pm$	ALL SURFACES					
		4 PL $\pm$						

©Copyright Xandex Inc., All Rights Reserved.  
The information disclosed herein is deemed to be confidential, proprietary, and a trade secret of Xandex, Inc. This information may not be used, reproduced or disclosed without the express prior written consent of Xandex, Inc.

REVISIONS					
REV	DESCRIPTION	CHANGE NUMBER	BY	DATE	APPROVED
-	SEE SHEET 1				

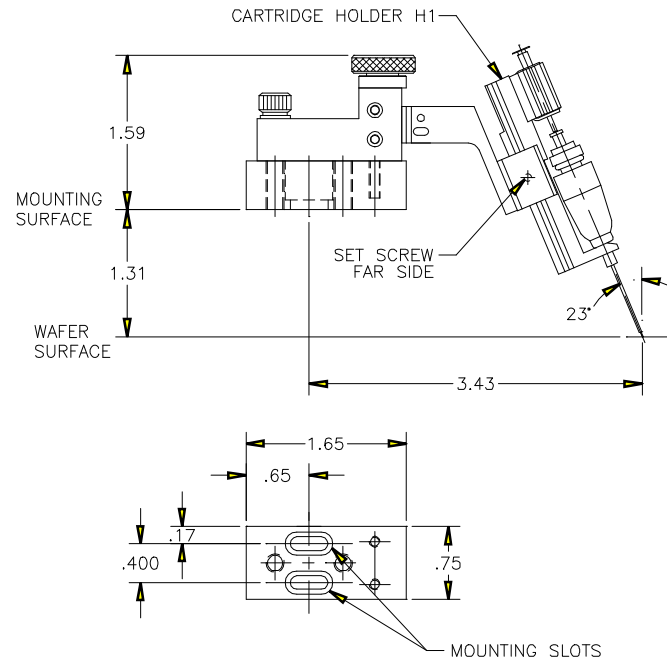

<b>XANDEX</b> INC.		TITLE INKER MODEL KLA 103 (KIT #330-1103)	
1125 N. McDOWELL BLVD. PETALUMA, CA 95954 (707) 763 7799		FILE NAME	9000091C
		DO NOT SCALE DRAWING	
SIZE	SCALE	SHEET	DRAWING NUMBER
A	1/1	2 of 2	900-0091
			REV
			C