

©Copyright Xandex Inc., All Rights Reserved. The information disclosed herein is deemed to be confidential, proprietary, and a trade secret of Xandex, Inc. This information may not be used, reproduced or disclosed without the express prior written consent of Xandex, Inc.					
REVISIONS					
REV	DESCRIPTION	CHANGE NUMBER	BY	DATE	APPROVED
B	REDRAWN ON CADD	1579	JMc	11/26/97	

NOTES:

- FOR IMS TEST SYSTEM WITH ELECTROGLAS PROBER, OVERHEAD TEST APPLICATION.
- MOUNTING RING IS CONNECTED TO PROBER INSERT RING USING TWO 4-40 X 1/4 SOC. HD. CAP SCREWS.
- HEX KEY WRENCHES ARE SUPPLIED WITH THIS UNIT.
- THIS INKER USES THE DM-1 AND DM-1.25 CARTRIDGES ONLY.
- ALL DIMENSIONS SHOWN WITH ADJUSTMENTS IN NEUTRAL POSITION.
- HOLDER ALLOWS ADJUSTMENT OF "Z" AXIS BY MOVING IN SLIDE BRACKET.
- COMPONENTS MAY BE ORDERED SEPARATELY: INKER BASE 400 (#320-0400) AND CARTRIDGE HOLDER H7-24E7 (#310-7252).
- FOR 5 MIL CARTRIDGES, RETROFIT CARTRIDGE HOLDER USING PLUNGER STOP ASSEMBLY #210-0016.

FILE NAME 9000103B	ITEM	QTY	PART NUMBER	DESCRIPTION
APPROVALS	DATE	INTERPRET DRAWING PER ANSI Y14.5 - 1982		
DRAWN JMc	2/26/97	1125 N. McDOWELL BLVD. PETALUMA, CA 95954 (707) 763 7799		
CHECKED		TOLERANCES UNLESS OTHERWISE SPECIFIED		
ENG'G		DIMENSIONS ARE IN INCHES		
ENG'G		DECIMALS		
NEXT ASSEMBLIES.....USED ON		1 PL ±	FRACTIONS ±	
		2 PL ±.010	ANGLES ±1°	
		3 PL ±.005	63/ ALL SURFACES	
		4 PL ±		
<b>DO NOT SCALE DRAWING</b>				
SIZE	SCALE	SHEET	DRAWING NUMBER	REV
A	1/1	1 of 2	900-0103	B

©Copyright Xandex Inc., All Rights Reserved. The information disclosed herein is deemed to be confidential, proprietary, and a trade secret of Xandex, Inc. This information may not be used, reproduced or disclosed without the express prior written consent of Xandex, Inc.					
REVISIONS					
REV	DESCRIPTION	CHANGE NUMBER	BY	DATE	APPROVED
-	SEE SHEET 1				

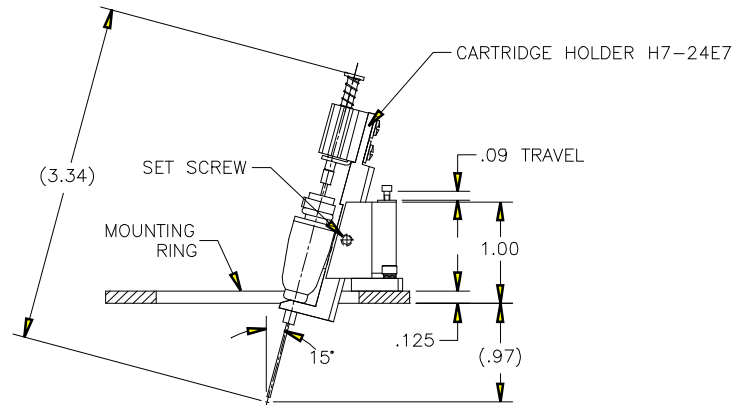
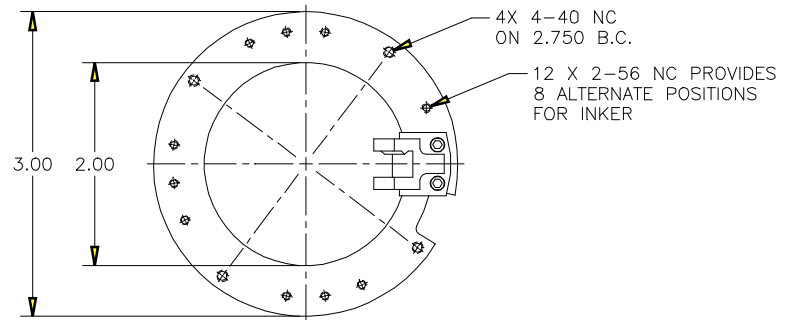

<b>XANDEX INC.</b>		1125 N. McDOWELL BLVD. PETALUMA, CA 95954 (707) 763 7799			
<b>DO NOT SCALE DRAWING</b>					
SIZE	SCALE	SHEET	DRAWING NUMBER	REV	
A	1/1	2 of 2	900-0103	B	

FILE NAME	9000103B	DO NOT SCALE DRAWING
TITLE	INKER MODEL 404 (KIT #330-0404)	
FILE NAME	9000103B	DO NOT SCALE DRAWING
TITLE	INKER MODEL 404 (KIT #330-0404)	
FILE NAME	9000103B	DO NOT SCALE DRAWING
TITLE	INKER MODEL 404 (KIT #330-0404)	