

©Copyright Xandex Inc., All Rights Reserved. The information disclosed herein is deemed to be confidential, proprietary, and a trade secret of Xandex, Inc. This information may not be used, reproduced or disclosed without the express prior written consent of Xandex, Inc.					
REVISIONS					
REV	DESCRIPTION	ECO	BY	DATE	APPROVED
A	INITIAL RELEASE	646	DT	8/13/93	DT
B	ADDED "S" CONFIG.	1333	DT	10/29/96	

NOTES:

1. INKER IS DESIGNED FOR USE ON LTX SYNCHRO AC & AC-"S" TESTERS. TEST HEAD MUST BE OUTFITTED WITH THE CLEAR PLASTIC GUARD (LTX PART NUMBER 852-3410-00).
2. INKER ADAPTER MOUNTS TO TEST HEAD USING (4) 4-40 X 1/2 LONG FLAT HEAD SCREWS (SUPPLIED).
3. X, Y ADJUSTMENT IS $\pm .062$. Z ADJUSTMENT CAPABILITY IS $\pm .125$ PLUS 3N ADDITIONAL .10 ADJUSTMENT TO ACCOMMODATE PROBE TIPS LONGER THAN .080.
4. INKER CAN BE USED WITH:
THE OPTEM HF-65 MICROSCOPE WITH A 0.7X-4.5X OBJECTIVE LENS.
MINIMUM WORKING DISTANCE IS 90mm (3.50").
5. ORDER INKER KIT EG3302 (PART No. 331-3302) FOR AC APPLICATIONS.
6. ORDER INKER KIT EG3306 (PART No. 331-3306) FOR AC-"S" APPLICATIONS.

FILE NAME	ITEM	QTY	PART NUMBER	DESCRIPTION
9000151B				
APPROVALS	DATE	INTERPRET DRAWING		
D. TEGLIA	8/13/93	PER ANSI Y14.5 - 1982		
TOLERANCES				
UNLESS OTHERWISE SPECIFIED				
JCC		DIMENSIONS ARE IN INCHES		
D. TEGLIA	11/5/93	DECIMALS		
NEXT ASSEMBLIES.....USED ON				
331-3302				
331-3306				
FRACTIONS \pm				
ANGLES \pm				
ALL SURFACES \checkmark				
DO NOT SCALE DRAWING				
SIZE	SCALE	SHEET	DRAWING NUMBER	REV
A	1/2	1 of 2	900-0151	B

©Copyright Xandex Inc., All Rights Reserved. The information disclosed herein is deemed to be confidential, proprietary, and a trade secret of Xandex, Inc. This information may not be used, reproduced or disclosed without the express prior written consent of Xandex, Inc.					
REVISIONS					
REV	DESCRIPTION	ECO	BY	DATE	APPROVED
-	SEE SHEET 1				

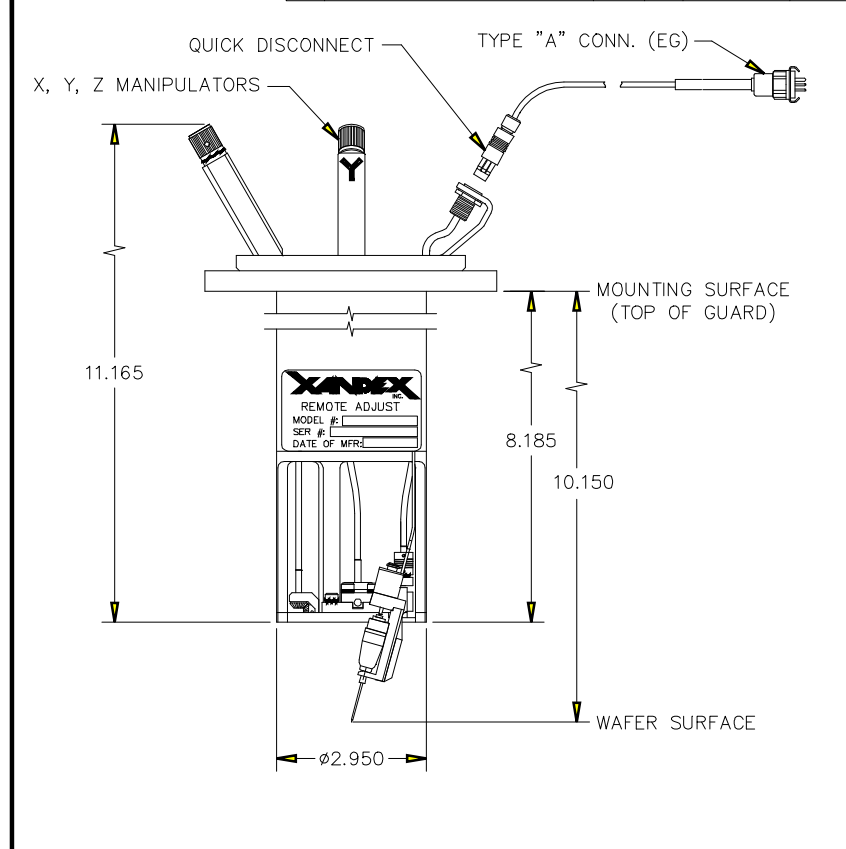

©Copyright Xandex Inc., All Rights Reserved. The information disclosed herein is deemed to be confidential, proprietary, and a trade secret of Xandex, Inc. This information may not be used, reproduced or disclosed without the express prior written consent of Xandex, Inc.					
REVISIONS					
REV	DESCRIPTION	ECO	BY	DATE	APPROVED
-	SEE SHEET 1				

XANDEX INC.					
1125 N. McDOWELL BLVD. PETALUMA, CA 95954 (707) 763 7799					
TITLE INKER SERIES 3300, LTX-AC & AC "S", R/A ELECTRIC					
FILE NAME 9000151B			DO NOT SCALE DRAWING		
SIZE	SCALE	SHEET	DRAWING NUMBER	REV	
A	1/2	2 of 2	900-0151	B	