

©Copyright 1993, Xandex Inc., All Rights Reserved.
 The information disclosed herein is deemed to be confidential, proprietary, and a trade secret of Xandex, Inc. This information may not be used, reproduced or disclosed without the expressed prior written consent of Xandex, Inc.

REVISIONS

REV	DESCRIPTION	ECO	BY	DATE	APPROVED
A	INITIAL RELEASE	586	DT	4/19/93	

NOTES:

1. REMOVE EXISTING Y110 INKER PARTS MOUNTED TO DOVETAIL BRACKET TO ALLOW INSTALLATION OF THE XANDEX HOLDER ASSEMBLY.
2. HOLDER ASSEMBLY IS MOUNTED TO EXISTING Y110 INKER AS SHOWN USING (2) 1-64 X 3/8 SCREWS (SUPPLIED).
3. ADAPTER ASSEMBLY USES DM-1 CARTRIDGES.
4. ORDER PART NUMBER 315-0003, S2-22C10.

FILE NAME 9000152A	ITEM	QTY	PART NUMBER	DESCRIPTION
UNLESS OTHERWISE SPECIFIED DIMENSIONS ARE IN INCHES TOLERANCES ON: 2 PL DECIMALS ± 3 PL DECIMALS ± ANGLES ± FRACTIONS ± MATERIAL: HEAT TREAT OR PLATING	SIGNATURES DRAWN D. TEGLIA CHECKED Q.C. ENGRG NEXT ASSY'S	DATE 04/13/93	 1125 N. McDOWELL BLVD. PETALUMA, CA 95954 (707) 763 7799 TITLE HOLDER ASSEMBLY S2 (Y110 RETROFIT)	
	SIZE A	FSCM NO A	DWG NO 900-0152	REV A
	SCALE 1/1		SHEET 1	OF 2

©Copyright 1993, Xandex Inc., All Rights Reserved.
 The information disclosed herein is deemed to be confidential, proprietary, and a trade secret of Xandex, Inc. This information may not be used, reproduced or disclosed without the expressed prior written consent of Xandex, Inc.

REVISIONS

REV	DESCRIPTION	ECO	BY	DATE	APPROVED
A	SEE SHEET 1				

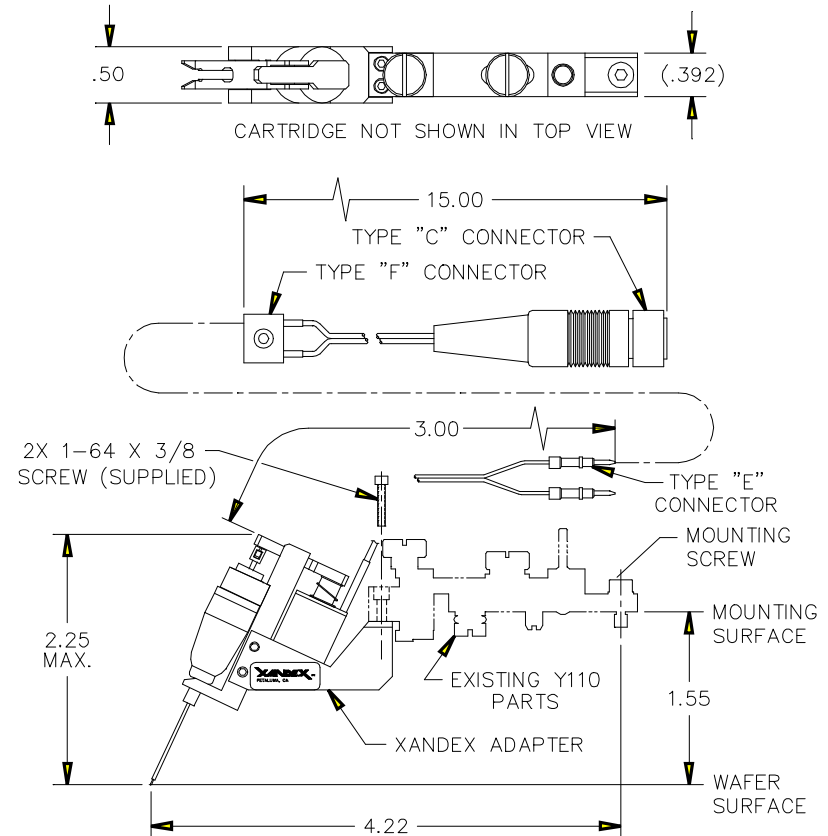

 1125 N. McDOWELL BLVD. PETALUMA, CA 95954 (707) 763 7799		TITLE HOLDER ASSEMBLY S2 (Y110 RETROFIT)	
SIZE A	FSCM NO A	DWG NO 900-0152	REV A
SCALE 1/1	FILE NAME 9000152A	SHEET 2	OF 2