

©Copyright Xandex Inc., All Rights Reserved.  
 The information disclosed herein is deemed to be confidential, proprietary, and a trade secret of Xandex, Inc. This information may not be used, reproduced or disclosed without the express prior written consent of Xandex, Inc.

REVISIONS					
REV	DESCRIPTION	CHANGE NUMBER	BY	DATE	APPROVED
A	INITIAL RELEASE	355	JMG	03/06/98	JMG
B	NOTE 2 WAS .001	D081	JMG	05/22/98	JMG
C	REV TO MAG BASE	1801	RAP	04/30/99	JG
D	MODEL NUMBER WAS 4110	2812	RK	01/20/03	

NOTES:

1. IN FACTORY SETTING, SHUTTLE TRAVELS .050 FROM POSITION SHOWN TO DEPOSIT INK ON WAFER. SHUTTLE TRAVEL IS USER ADJUSTABLE FROM 0 TO .050 INCHES.
2. INKER HAS VERTICAL (Z) ADJUSTMENT CAPABILITY OF  $\pm .18$  IN INCREMENTS OF .0005, FROM NOMINAL POSITION SHOWN.
3. INKER USES "JOYSTICK" FOR X AND Y POSITIONING.
4. INKER USES DM-2 TYPE INK CARTRIDGES.
5. INKER MOUNTS TO EG PROBER USING (2) 4-40 X 3/8 LONG FLAT HEAD SOCKET SCREWS (SUPPLIED).
6. FOR EG PROBERS, ORDER KIT 340-4115.

©Copyright Xandex Inc., All Rights Reserved.  
 The information disclosed herein is deemed to be confidential, proprietary, and a trade secret of Xandex, Inc. This information may not be used, reproduced or disclosed without the express prior written consent of Xandex, Inc.

REVISIONS					
REV	DESCRIPTION	CHANGE NUMBER	BY	DATE	APPROVED
-	SEE SHEET 1	-	-	-	-

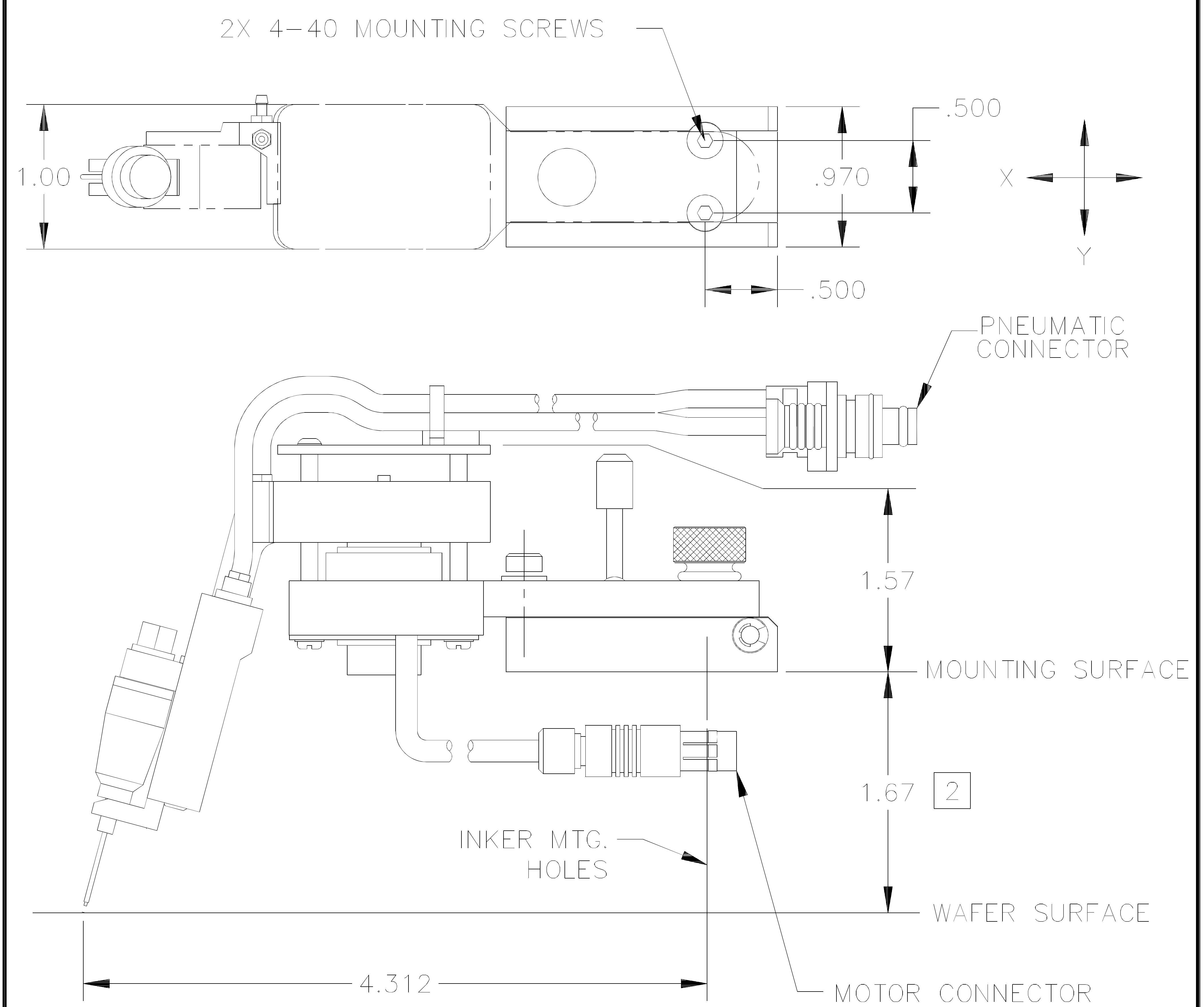

APPROVALS	DATE	ITEM	QTY	PART NUMBER	DESCRIPTION
DRAWN JAMES G.	03/05/98	INTERPRET DRAWING PER ASME Y14.5M-1994			1125 N. McDOWELL BLVD. PETALUMA, CA 94954 (707) 763 7799
CHECKED		TOLERANCES UNLESS OTHERWISE SPECIFIED			
ENGRG JAMES G.	05/22/98	DIMENSIONS ARE IN INCHES DECIMALS			TITLE MOTOR Z INKER, X4115 PNEUMATIC
NEXT ASSEMBLIES.....USED ON		1 PL $\pm$ FRACTIONS $\pm$			DO NOT SCALE DRAWING
		2 PL $\pm .010$ ANGLES $\pm 1^\circ$			SIZE A
		3 PL $\pm .005$			SCALE 1/1
		4 PL $\pm$ 63 $\sqrt$ ALL SURFACES			SHEET 1 OF 2
					DRAWING NUMBER 900-0202
					REV D

1125 N. McDOWELL BLVD. PETALUMA, CA 94954 (707) 763 7799				
TITLE MOTOR Z INKER, X4115 PNEUMATIC				
SEE SHEET 1 FOR NOTES AND TOLERANCE INFORMATION			DO NOT SCALE DRAWING	
SIZE A	SCALE 1/1	SHEET 2 OF 2	DRAWING NUMBER 900-0202	REV D