

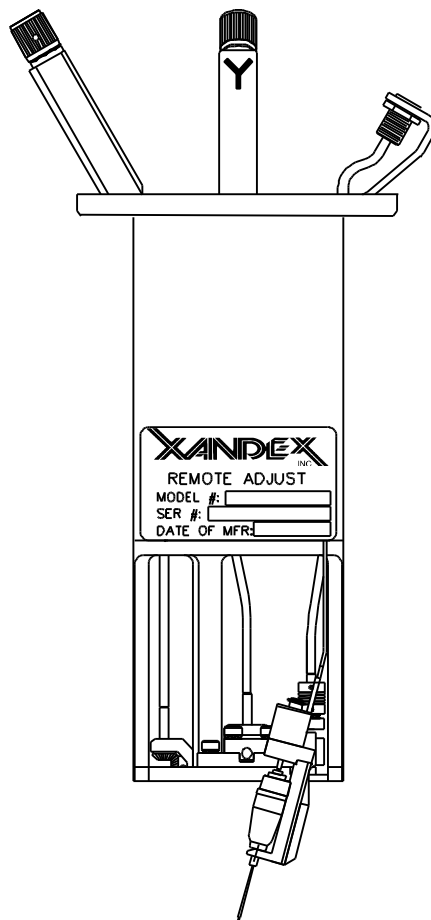

EG3000 SERIES ELECTRIC
REMOTE ADJUST INKER FOR EG20XX / KLA
LTX Trillium Micromaster, Deltamaster PLATFORM
INSTALLATION AND OPERATION MANUAL



OBSOLETE

TABLE OF CONTENTS

SECTION 1. INTRODUCTION.....	1-1
Theory of Operation	1-1
SECTION 2. SYSTEM OVERVIEW.....	2-1
EG3100, EG3110 & EG3200 System Components	2-1
SECTION 3. INSTALLATION.....	3-1
EG3100, EG3110 & EG3200 Inker Adapter Installation	3-1
EG3100, EG3110 & EG3200 Inker Installation	3-1
EG3100, EG3110 & EG3200 Holder Arm.....	3-1
SECTION 4. SYSTEM OPERATION	4-1
Inker Operation.....	4-1
Ink Cartridge	4-2
Ink Cartridge Installation	4-6
Inker Alignment.....	4-7
Cartridge Holder Arm Adjustment	4-8
SECTION 5. INK.....	5-1
General Information.....	5-1
Ink Curing	5-2
Ink Removal	5-3
SECTION 6. MAINTENANCE/TROUBLESHOOTING	6-1
Ink Cartridge Troubleshooting	6-1
Inker Assembly Troubleshooting.....	6-3
Inker Drive Verification	6-5
SECTION 7. OPTIONS	7-1
Ink Dot Counter Box Kit	7-1
SECTION 8. SYSTEM SPECIFICATIONS.....	8-1
APPENDIX A. INKER WARRANTY	8-2
APPENDIX B. DRAWINGS	8-3

Section 1. Introduction

Theory of Operation

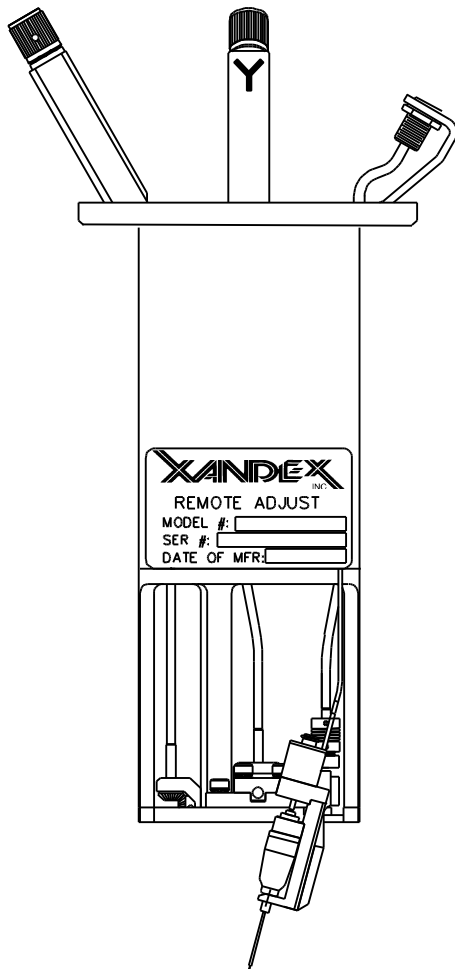

The EG3000 series Electric Remote Adjust is an in-line inker that incorporates easy installation and removal from the tester, with the added ability to change ink cartridges without undocking the test head. Precise X, Y, and Z adjustments to the inker are possible while the test head is docked and the microscope is in position.

This manual includes installation and operation instructions for the following Electric Remote Adjust Inkers;

- EG3100 (LTX Trillium 1 Pogo Stack/ EG 20XX)
- EG3110 (LTX Trillium 1.5 Pogo Stack/ EG 20XX)
- KLA3200 (LTX Trillium 1.5 Pogo Stack/ KLA)

The EG3000 series utilizes standard DieMark™ DM-1 cartridges, is available in a variety of configurations and is installed on the test head with the addition of a simple adapter.

Ink dots are deposited via solenoid actuation of the DieMark™ cartridge nylon filament, which barely contacts the wafer surface. DieMark™ cartridge needle size, fishline diameter, fishline length, and ink viscosity are factory tuned. A standard ink reservoir is combined with a variety of needle and fishline configurations for different applications and dot sizes.

Thank you for selecting ...  ...as your inking choice.

Please spend a few minutes familiarizing yourself with the unit. Most questions you may have will be answered in this manual. If you would like further assistance, please contact your local Xandex distributor or call us at (707) 763-7799 or Toll Free in the U.S: (800) 767-9543. FAX (707) 763-2631. For more information about Xandex and our complete line of quality inking and interfacing products, visit us on the internet at www.xandex.com or email info@xandex.com

This page is intentionally left blank.

Section 2. System Overview

System Components / LTX TRILLIUM MICROMASTER & DELTAMASTER

Kit Part No. 331-3100 (EG3100) 1² Pogo Stack (EG)

Kit Part No. 331-3110 (EG3110) 1.5² Pogo Stack (EG)

Kit Part No. 331-3200 (KLA3200) 1.5² Pogo Stack(KLA)

1. Electric Remote Adjust Inker Assembly
Part No. 320-3101
2. Cable Connector
Part No. 210-0111
(EG applications)
3. Cable Connector
Part No. 210-0112
(KLA applications)
4. Adapter Assembly,
EG3100 / EG3110
/ KLA3200
Part No. 220-0010

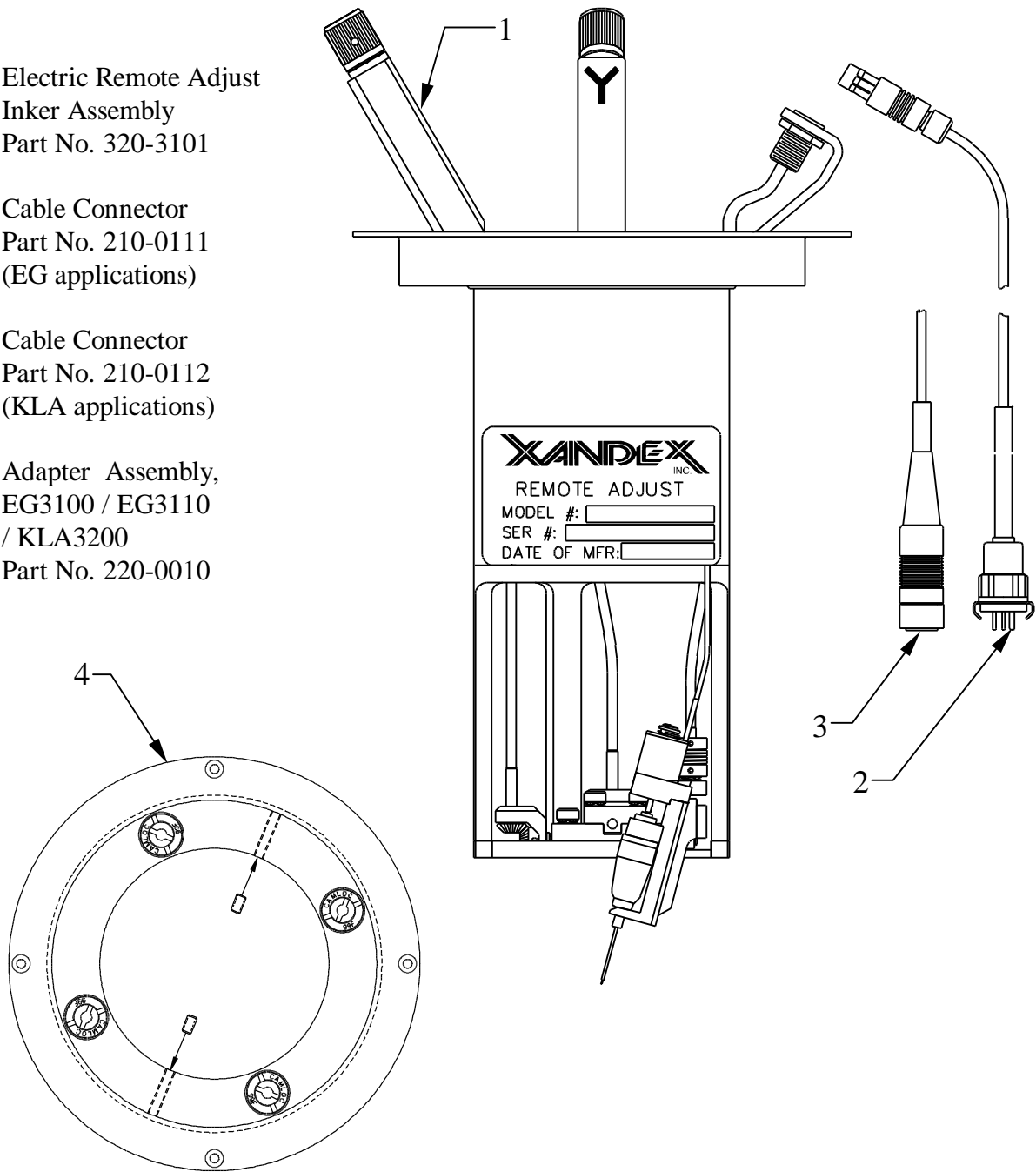

This page is intentionally left blank.

Section 3. Installation

LTX TRILLIUM

The Xandex EG3100 (1" pogo stack) and EG3110 (1.5" pogo stack) Remote Adjust Inkers are designed for use on an LTX Trillium test head docked to an Electroglas prober. The Xandex KLA3200 Remote Adjust Inker is designed for use on an LTX Trillium test head docked to a KLA prober. The inker is installed onto the test head with the addition of an adapter assembly. No other modification to the prober or test head is necessary. Removal of the microscope is necessary only to change ink cartridges, as inker X, Y and Z adjustments can be made with the microscope in place. Remote adjust inkers require the use of the Black Trillium Shield. This is to allow proper inker clearance and mounting. If you do not have one available, you may order one direct from LTX Trillium: Trillium Black Shield P/N A530419-01. The following describes the steps necessary to install the EG3000 Series Remote Adjust Inker.

Adapter Installation

1. Remove the microscope from the test head.
2. Remove any current inker in use from the test head.
3. Remove the white top cover from the test head.
4. Remove the four flat head screws retaining the black guard. Mount the inker adapter ring assembly (P/N 220-0010) on the Black guard.
5. Insert the four flat head screws through the inker adapter ring and black guard and tighten.
6. Re-install the white top cover. The adapter ring will remain permanently affixed.

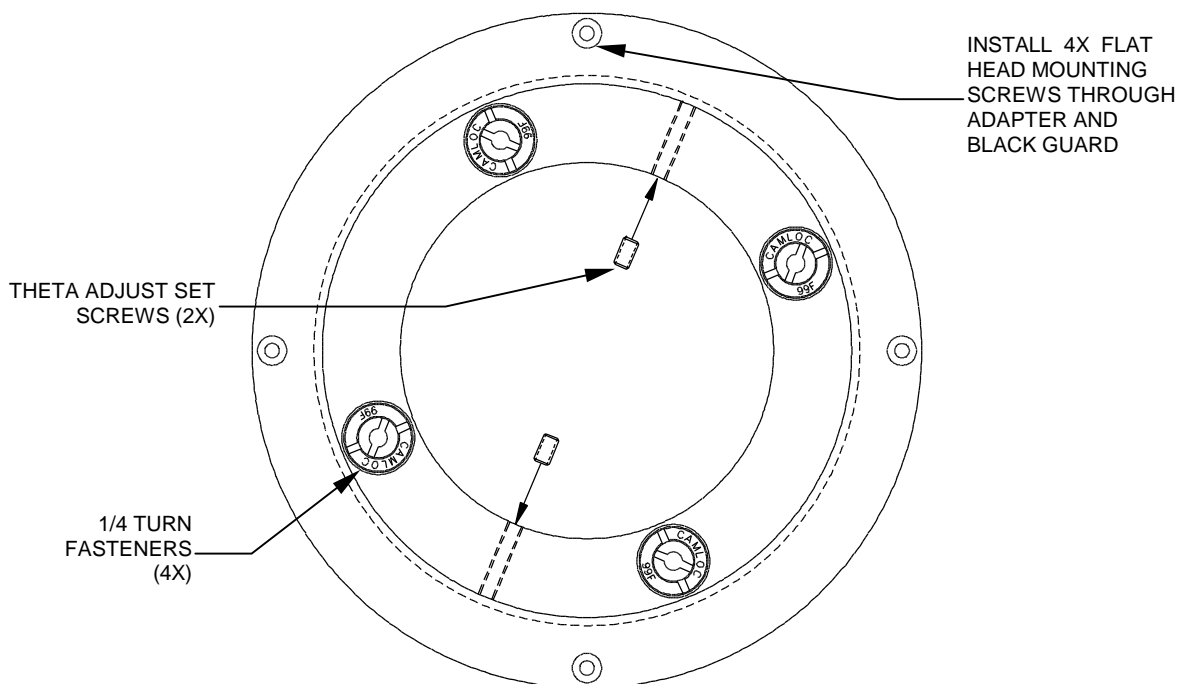

7. If necessary, theta adjustment of the inner ring (which is integral to the adapter ring) can be accomplished by loosening the two Allen head set screws and rotating the inner ring so that the X and Y axis of the Remote Adjust coincide with the X and Y movements of the prober. Re-tighten the set screws after adjustment is complete.

Inker Installation

1. To prepare the inker for installation, set the Z height all the way up by turning the *Z adjust knob* counter-clockwise until the *Z bracket (dovetail)* reaches the top of its travel.
2. Set the inker X and Y positions to their approximate mid-points by turning the *X and Y knobs* clockwise until they reach the end of their travel and then backing them off approximately 1 & 3/4 turns.
3. Plug the *quick disconnect* end of the *cable* (P/N 210-0111 for EG probers or 210-0112 for KLA probers) into the receptacle on the inker. Connect the other end of the *cable* to the inker jack on the prober.
4. Run an inker test on your prober to make sure the inker solenoid actuates.
5. Lower the Remote Adjust inker assembly onto the adapter ring and tighten the four (4) 1/4 turn fasteners.
6. Align the microscope with the hole in the center of the inker and lower the microscope into the test head until you are able to bring the probe tips into focus. The tip of the *cartridge holder* should be visible.
7. Using the *Y adjust knob* on the inker, check the full travel in the Y direction to see if the inker is approximately centered over the probe tips.
8. Repeat the process for the X travel. Without a cartridge in place, use the tip of the cartridge holder as a reference. When viewed through the microscope the X travel of the inker will be centered when the tip of the holder is approximately 0.122 inches from the center of the probe card. As a gauge, full travel in X is approximately 0.125 inches ($\pm 0.062''$).
9. If the inker mechanism appears to be centered, remove the microscope and inker. Proceed to **Section 4 “System Operation”** for setup, alignment and cartridge installation procedures.

Inker Removal

1. Remove the microscope and drop the prober stage to Z down.
2. Unlock the 4 captive 1/4-turn fasteners and lift the inker assembly straight up and out of the test head.

Cartridge Holder Mounting Arm Conversion

The cartridge holder mounting arm can be changed to adapt the Remote Adjust inker to 1" or 1.5" Trillium pogo stacks. For conversion from 1" to 1.5" pogo stacks order Part Number 120-0007. For conversion from 1.5" to 1" pogo stacks order Part Number 120-0005.

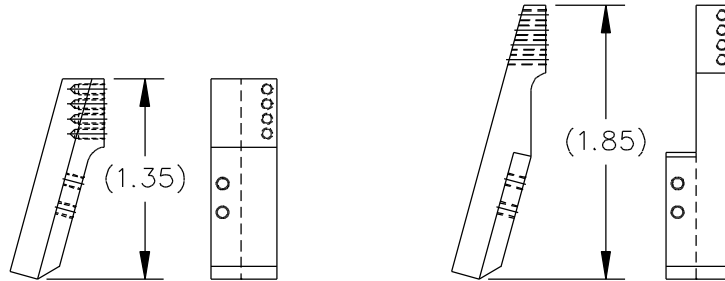

CARTRIDGE HOLDER MOUNTING ARM
P/N 120-0005
1 INCH TRILLIUM POGO STACK

CARTRIDGE HOLDER MOUNTING ARM
P/N 120-0007
1.5 INCH TRILLIUM POGO STACK

1. Remove the ink cartridge (if installed).
2. Remove the two cartridge holder mounting screws, set them aside, and remove the cartridge holder from the mounting arm.
3. Remove the two cartridge holder mounting arm retaining screws, set them aside, and remove the mounting arm from the inker base.
4. Install the new mounting arm onto the inker base using the screws removed in step 3. Apply a dab of Loctite 222 to the screws before installation.
5. Install the cartridge holder on the new mounting arm with the screws removed in step 2. Apply a dab of Loctite 222 to the screws before installation.
6. The mounting arm screw holes are 0.10" apart and allow for arm adjustment of 0.10".
7. Check inker alignment per instructions before re-installing the ink cartridge.

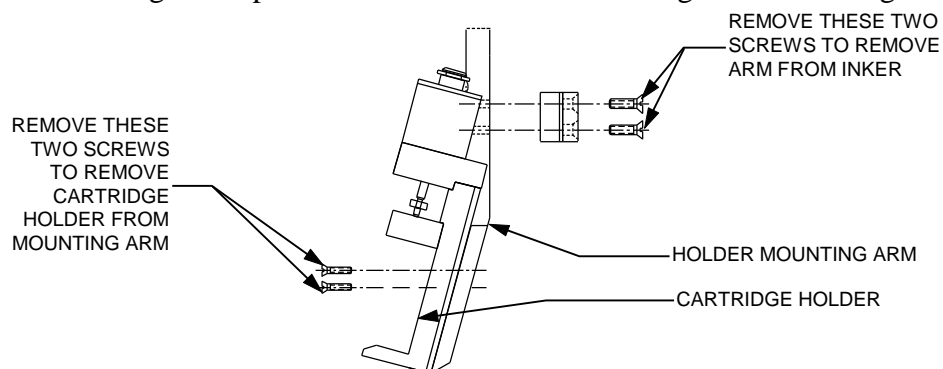

This page is intentionally left blank.

Section 4. System Operation

Remote Adjust Inker Operation

Inker Actuation:

The EG3000 Series Electric Remote Adjust Inker operates via an electronic pulse sent from the prober to actuate the solenoid. Upon actuation, the solenoid plunger drives the cartridge filament to the fully extended position, making slight contact with the wafer surface and depositing an ink droplet forming a dot. The electronic pulse will vary depending on the coil drive voltage (48VDC minimum), as well as the pulse width and duty cycle. It is recommended that the drive voltage of the pulse is at least twice the solenoid coil voltage specification (i.e., 24VDC solenoid = 48VDC drive voltage). The pulse width will vary depending on the drive voltage, as shown below:

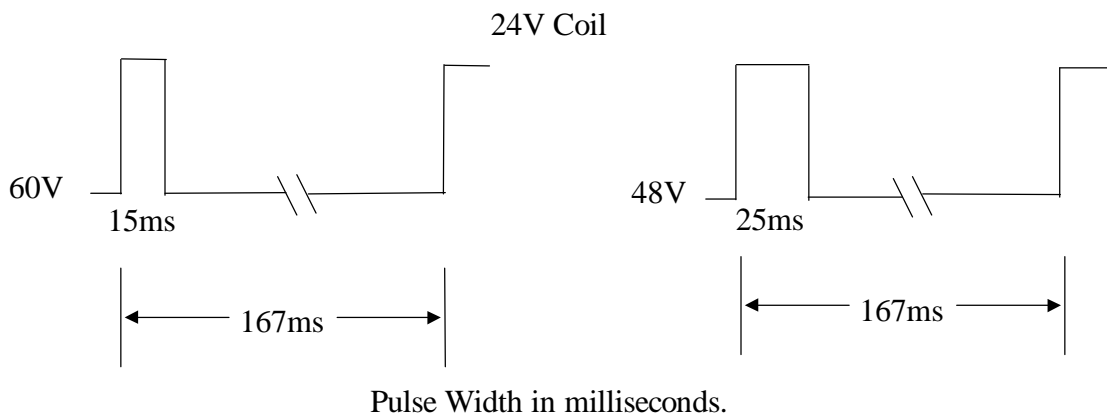

For voltages greater than 60VDC the on time of the cycle must be shortened. Maximum coil operating temperature must not exceed 100°C. The inker should not be operated more than 10 cycles without an ink cartridge installed (the cartridge can be empty) or damage to the solenoid may occur. 167ms is the minimum total cycle time. If faster inking is required, a pneumatic inker is recommended.

The duty cycle is a function of the time the solenoid is energized versus the total cycle time, as shown below where t_1 = time on and t_2 = time off. For example;

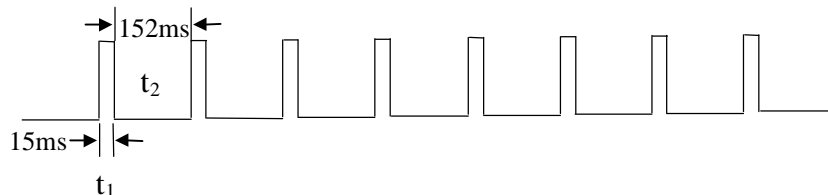

$$\text{Duty Cycle (as \%)} = \frac{t_1}{(t_1 + t_2)} \times 100 \quad \text{or} \quad \frac{15}{(15 + 152)} \times 100 = 8.9\%$$

A duty cycle of 20% is acceptable, <10% is optimal. If problems exist with the inker actuation, please refer to “Inker Drive Verification” as detailed in **Section 6 “Maintenance & Troubleshooting”** of this manual.

Ink Cartridge

EG3000 Series Electric Remote Adjust Inkers use standard DM-1 cartridges, available in a variety of sizes. The DM-1 cartridge has a polypropylene reservoir and monofilament fishline encased in a stainless steel needle. After opening and priming, the monofilament fishline wicks the ink to the filament tip each time the inker fires. The DM-1 cartridge contains approximately 0.60 grams of ink in the reservoir. For dot production figures and related information see **Section 5 “Ink,”** and **Section 8 “System Specifications.”**

DM-1 Ink Cartridge Overview

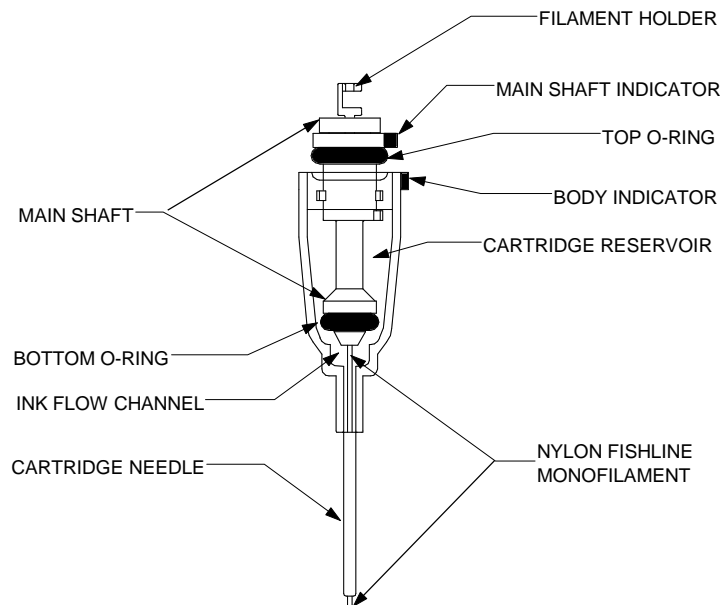

- **Cartridge Description**

A cartridge is an ink reservoir sealed by two O-rings, top and bottom. A monofilament fishline passes through the cartridge main body and needle and is attached at the top to the filament holder.

- **Open Cartridge Description**

A cartridge is opened by pulling the main shaft up to lift the bottom O-ring and open up the ink flow channels.

- **Cartridge Priming**

Priming is necessary to establish continuous ink flow into the cartridge needle. The cartridge is primed by lifting the main shaft (and bottom O-ring) to fill the reservoir under the bottom O-ring with ink and actuating the filament, coating it with ink all the way to the needle tip. The cartridge is ready for use when the ink flow channels are open (i.e., bottom O-ring is raised and the space below the bottom O-ring is full of ink), the filament is coated with ink to the needle tip and the main shaft is locked in position so that it cannot move up or down. Detailed cartridge opening, priming and installation instructions appear later in this section.

Ink Cartridge Labeling

DieMark™ ink cartridges are individually labeled with two distinct labels. One label shows the cartridge dot size and the other label indicates the ink batch number, ink type and expiration date of the cartridge.

Do not remove the labels from the cartridges as this can cause cartridge type and ink types to be confused at cartridge installation, resulting in improper performance. Removal of cartridge labels will also void the cartridge warranty.

DieMarkä Cartridge Type Label

This label contains the cartridge dot size, (10mil, 15mil etc.).

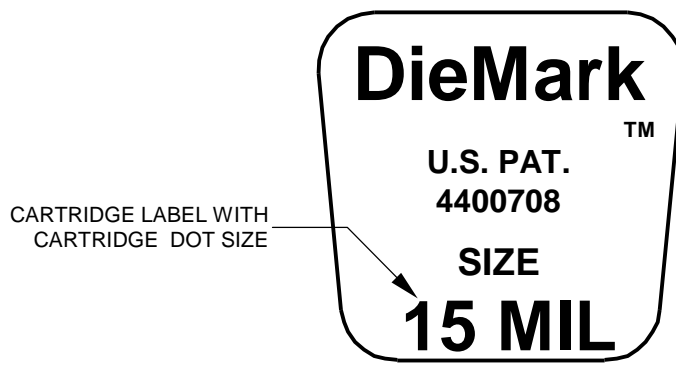

DieMarkä Cartridge Expiration Date Label

This label indicates the ink type, the batch number of the ink contained in the cartridge and the cartridge expiration date. Expiration dates shown are for *unopened* cartridges.

- ◆ Markem® 6990, 6993, 6997 and Xandex 8103 = Four (4) months.
- ◆ Xandex 7824 and 7824T = Two (2) months.

After the cartridge is opened, consistent ink flow can only be expected for up to five (5) days for Markem® 6990, 6993, 6997 and Xandex 8103 and three (3) days for Xandex 7824 and Xandex 7824T.

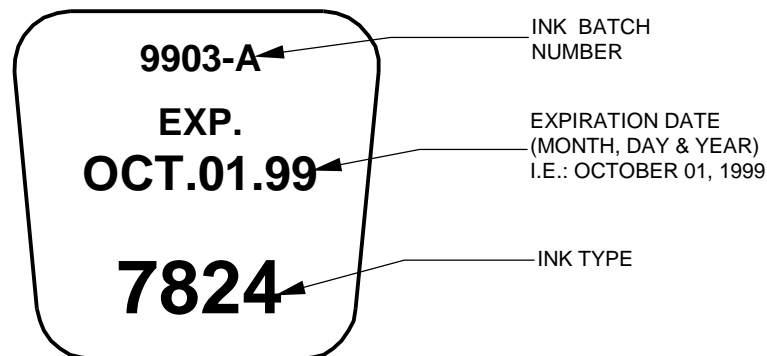

Opening the Cartridge

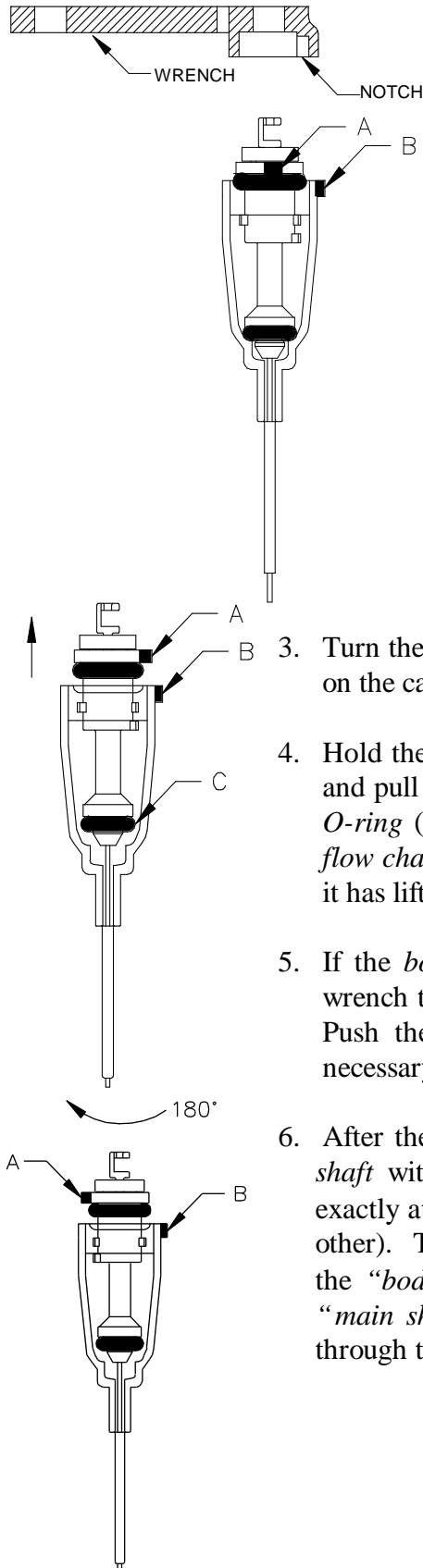

A plastic wrench is used to open and prime a cartridge. The wrench fits very tightly and has a shallow cup with a notch to fit over the top of the main shaft. The notch location is indicated by an alignment "bump" on the end of the wrench.

- Two reference points on the ink cartridge are used in opening and priming the cartridge.
 - An alignment "bump" at the top of main shaft called the "main shaft indicator" (A).
 - An alignment "bump" on the cartridge body near the top called the "body indicator" (B).
- Align the "main shaft indicator" (A) with the notch in the wrench and fit the wrench over the top of the main shaft.
- Turn the "main shaft indicator" (A) towards the "body indicator" (B) on the cartridge until they are aligned.
- Hold the wrench at the cup section, between thumb and index finger, and pull up the main shaft with the wrench until it stops. The bottom O-ring (C) should be lifted from its sealed position, opening the ink flow channels. Visually inspect the bottom O-ring (C) and verify that it has lifted and the ink is flowing into the channels.
- If the bottom O-ring is not lifted, close the cartridge by using the wrench to re-align the "main shaft indicator" and "body indicator". Push the main shaft down to re-seat it. Repeat this procedure if necessary until the bottom O-ring is lifted.
- After the main shaft and the bottom O-ring are lifted, turn the main shaft with the wrench until the indicators (A & B) are positioned exactly at opposite sides of the cartridge (at 180° with respect to each other). There is a small hole at the top of the wrench through which the "body indicator" (B) can be seen when it is at 180° from the "main shaft indicator" (A). Turn the wrench slowly while looking through this hole for the "body indicator" (B).

Priming the Cartridge

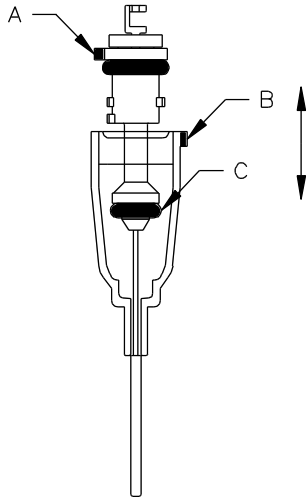

The purpose of priming the cartridge is to insure that the lower reservoir and the *ink flow channels* below the *bottom O-ring* are completely filled with ink. This will insure even, continuous ink flow. To prime the cartridge follow the steps below.

1. Hold the cartridge steady in one hand and the wrench at the cup area (top of the *main shaft*) with the other.
2. Keeping the indicators at 180° from each other, pull up very gradually and lift the *main shaft* while wiggling the wrench slightly from side to side.
3. Stop lifting the *main shaft* when it is 2/3 out of the reservoir.
4. Lower the *main shaft* back to its original position while stirring the ink.
5. Repeat steps 1-4 two to three times until space below the *bottom O-ring* is completely filled with ink.
6. Lower the *main shaft* the final time as far down as it will go (until it stops). The *indicators* should still be 180° from each other and the *main shaft* back down to the pre-prime position.
7. Turn the *main shaft* 1/4 turn in either direction. This locks the *main shaft* in position so that it cannot be moved up or down. There should be a gap between the *top O-ring* and the *cartridge body*. Push the *filament holder* down and remove the wrench. The cartridge is now primed and ready for installation on the inker.

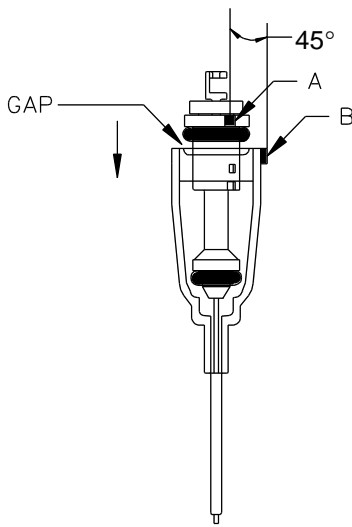

Cartridge Inspection

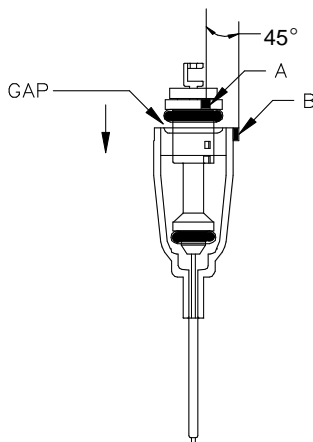

Visually inspect the primed cartridge before installing it on the inker and verify that the following conditions exist;

- The *bottom O-ring* is lifted and the *ink flow channels* under the bottom O-ring are completely filled with ink.
- The cartridge *alignment indicators* are 1/4 turn from each other. This way the *main shaft* cannot be pushed up or down.
- There is a *gap* between the *top O-ring* and the *cartridge body* indicating that the cartridge has not been inadvertently closed.

Cartridge Installation

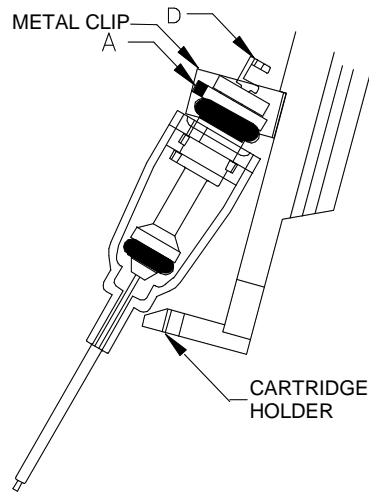

1. Verify that the *filament holder* (D) has been pushed down.
2. Push the *main shaft* section into the *metal clip* on the *cartridge holder*. Make sure the “*main shaft indicator*” (A) is pointing outwards. Press the *cartridge body* until it snaps into place. Verify that the *gap* has not closed and the *indicators* are still 1/4 turn from each other. If these conditions are NOT satisfactory, remove the cartridge from the clip and review the priming procedure.

3. Align the *solenoid plunger* with the *filament holder* (D) and push the *plunger* until it snaps into the *filament holder*. In this position the *plunger* should move up and down freely. Manually depress the *plunger* a number of times to verify operation, occasionally rotating the *plunger* to insure free movement.
4. Exercise the *plunger* manually or electrically until ink flow is established in the *stainless steel needle* and the *monofilament* is coated with ink. A standard DM-1 cartridge requires a minimum of 30-40 *plunger* strokes to properly establish ink flow. When the *filament* is completely coated with ink, check the *needle tip* for excess ink and wipe with a clean lint free cloth if necessary.

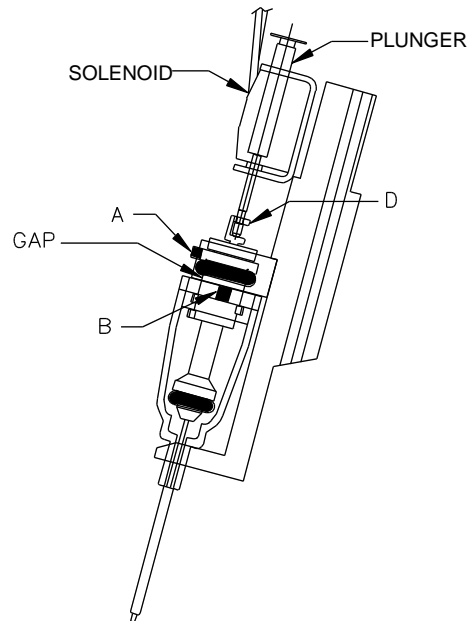

Inker Alignment

1. Prepare, prime and install a cartridge per the instructions in this section (4). Cartridge priming is done prior to the cartridge being installed into the inker. Once priming is completed, snap the cartridge into the inker per the instructions.
2. With the chuck still in a safe position out from under the probe card, and the Z height of the inker set all the way up, install the inker onto the adapter assembly in the test head.



CAUTION : *Be careful to lower the inker straight down, so as not to damage the cartridge tip or probe needles.*

3. Re-install the microscope and focus on the cartridge tip. Center the cartridge tip to the probe tips using the X/Y adjustment knobs.
4. While viewing the probe tips from the under side of the ring carrier with the Z height set all the way up, the cartridge tip should be above the probe tips. If the cartridge tip is above the probe tips, turn the *Z adjust knob* clockwise to lower the cartridge. If you are able to extend the cartridge beyond the probe tips, you are now ready for inking.
5. If the cartridge tip extends past the probe tips in the full Z up position, or the cartridge tip still does not protrude below the probe tips in the full Z down position, an adjustment to the *holder mounting arm* must be made. Proceed to “**Adjusting Holder Mounting Arm Height**” in this section .

Note: *As built, your Remote Adjust inker will work with an interface and probe cards with an .080 tip depth. If you have a different interface or probe card, it may be necessary to adjust the mounting of the cartridge holder arm, to accommodate other interfaces .*

Adjusting Holder Mounting Arm Height

If the cartridge tip does not extend past the probe tips with the inker in the full Z down position or the cartridge tip protrudes below the probe tips with the inker in the full Z up position, adjustment of the cartridge holder arm is required. Remove the inker from the test head and perform the following procedure.

1. To raise or lower the *cartridge holder* height, remove the two slotted, flat head screws retaining the *holder mounting arm* to the Z (*dovetail*) bracket. The mounting holes on the arm are spaced in increments of 0.10 inches.

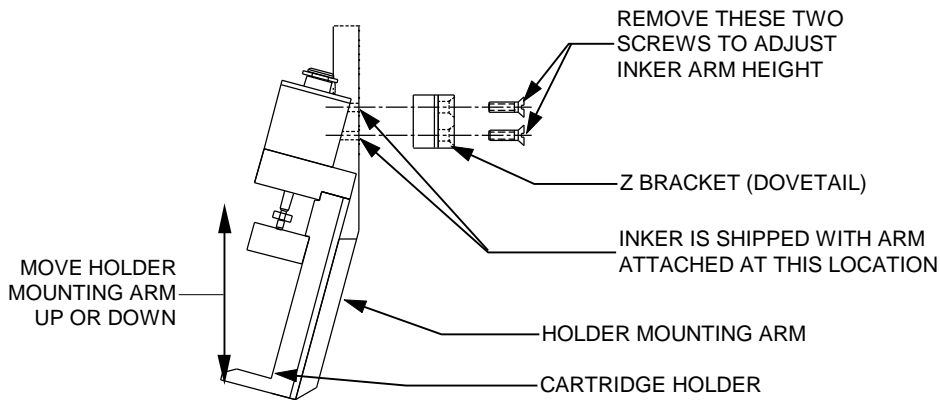

2. Raise or lower the arm according to your height change requirements. The *holder arm* is at the correct height when the tip of the cartridge adequately clears the probe tips when the inker is in Z up position, and the cartridge tip extends beyond the probe tips in Z down adjustment.
3. Re-install the two slotted flat head screws. Use a dab of Loctite 222 on the screws before installing. Make sure the *holder arm* is flush against the notch in the Z (*dovetail*) bracket when tightening the screws.
4. Re-install the inker in the test head and check the Z height setup to verify proper adjustment.

Final Setup and Adjustments

1. Prepare, prime and install an ink cartridge per the instructions in this section (4).
2. With the chuck still in a safe position out from under the probe card, verify the inker Z height is set to full Z up (full counterclockwise *Z adjust knob* adjustment) position before installing the test head.
3. Re-install the microscope and focus on the *cartridge tip*.
4. Place a sample or scrap wafer on the chuck and move directly under the cartridge tip. Raise the chuck height to normal Z inking position.
5. While monitoring the cartridge/wafer surface through the microscope, fire the inker a few times and inspect the results. Slowly turn the *Z adjust knob* clockwise while firing the inker until dots begin to appear on the wafer surface. The cartridge *filament* should barely contact the wafer surface.

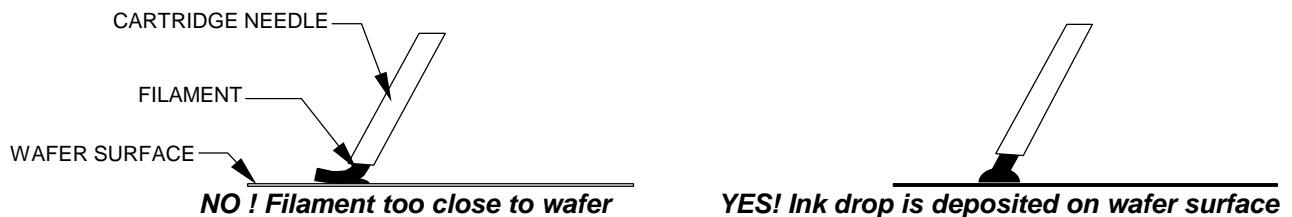

CAUTION: Do not allow the cartridge tip to contact the wafer surface while performing Z Height adjustment. Damage to the filament and/or wafer surface may occur.

6. Adjust the Z height with the *Z adjust knob* until dots are round and of proper size. The cartridge *filament* should barely contact the *wafer surface* only close enough so the ink droplet wicks off onto the wafer surface.
7. Remove the sample/scrap wafer and replace with a production wafer. Move chuck under the inker and perform X & Y adjustment to desired die position.

This page is intentionally left blank.

Section 6. Maintenance/Troubleshooting

This Troubleshooting section for the EG3000 Series Electric Remote Adjust Inker is divided into two parts. The first part covers the ink and the DM-1 ink cartridge. The second part covers the Remote Adjust Inker.

Troubleshooting the DM-1 Ink Cartridge

Problem	Solution
The lower O-ring does not lift when opening a cartridge.	This sometimes occurs when ink dries around the lower O-ring. Push the main shaft down, keeping the indicators aligned. Then pull up the shaft while slanting it to one side as much as possible to lift the O-ring.
The cartridge is opened per instructions and the fishline comes out smoothly, but the ink does not flow down the needle.	It usually takes 30 to 40 strokes before the phenolic inks travel all the way down the needle. Viscous epoxy and air dry inks may require longer. After priming, but before the inker is installed into the test head, manually activate the plunger 30 to 40 strokes until ink appears at the needle tip.
Some ink dots tend to crack after baking using Xandex recommended cure cycles.	This occurrence is related to the ink surface tension, wafer surface conditions and too long a delay time between inking and curing. To remedy this situation, the curing cycle has to be modified (reduce time and temperature). See Section 5 “Ink Curing.”
Runny, blobbing ink or skipping dots.	<ol style="list-style-type: none"> <li data-bbox="638 1108 1425 1297">1. Check ink shelf life. Markem[®] 6990, 6993, 6997 and Xandex 8103 inks should be used within 4 months or 5 days of cartridge opening. Xandex 7824 and Xandex 7824T air dry ink within 2 months or 3 days after cartridge opening. <li data-bbox="638 1339 1425 1570">2. Check for exposure to extreme temperatures. Store cartridges at 25° C. DO NOT refrigerate the cartridges. Occasionally, ink is subjected to much higher temperatures (40-50° C) for an extended time during transport. This could break down the ink such that its viscosity and surface tension are altered permanently. <li data-bbox="638 1612 1425 1759">3. Inker Z height may be adjusted too high. Ink can not wick off the filament and builds up, creating blobbing and skipping. Readjust inker Z height and alignment. See Section 4 “Final Setup and Alignment.”

Problem	Solution
<p>Small, inconsistent, skipping or no ink dots.</p>	<ol style="list-style-type: none"> 1. The ink flow channels may be blocked. This could be due to any one of the following: <ol style="list-style-type: none"> A. The bottom O-ring is not lifted at all. In this case, when the cartridge is primed only a small amount of the ink flows into the space below the O-ring. This is enough to start inking, but the inker quickly uses up that ink (i.e., on two or three wafers) and will start to skip. To eliminate the problem, close the cartridge, re-open and prime again. See Section 4 "Opening the Cartridge." B. The cartridge is opened and primed correctly but is closed inadvertently before it is mounted on the holder. The main shaft is pushed down all the way, leaving no gap and the fishline appears to be too long. To correct this problem, pull up the main shaft until it stops, then turn it 1/4 of a turn in either direction. See Section 4 "Priming the Cartridge." C. During priming, an air bubble may have become trapped under the bottom O-ring. This inhibits the full flow of ink. To eliminate air bubbles, reseal the cartridge and repeat the priming procedure in Section 4. 2. Verify that coil and cartridge are in line, visually check the straightness of the plunger and check for possible damage to the plunger spring. The plunger should travel smoothly and freely when actuated manually from any position. If there is any binding replace the plunger and/or spring. 3. Chuck top or wafer surface not planar. Verify planarity of both. 4. Inker Z height may be adjusted too high. Re-adjust inker Z height and alignment. See Section 4 "Final Setup and Alignment." 5. Incorrect inker drive, in which case the plunger will travel very sluggishly. See "Inker Drive Verification" later in this Section (6).
<p>Elongated instead of round dots.</p>	<ol style="list-style-type: none"> 1. Inker is set too close to the wafer, which results in a kinked fishline. The cartridge should be positioned so that the filament barely touches the wafer surface when it is fully exposed. See Section 4 "Final Setup and Alignment."

Troubleshooting the Electric Remote Adjust Inker

Problem	Solution
Cartridge tip does not reach wafer surface.	<ol style="list-style-type: none"> 1. If you are using probe cards with needle depth of greater than 0.080", you can adjust the inker arm mounting down 0.10" to accommodate the longer probe tips. See Section 4 "Adjusting Inker Height."
Unable to make X, Y or Z adjustments.	<ol style="list-style-type: none"> 1. Visually inspect installation to make sure there is nothing interfering with the X, Y or Z travel (i.e., wires, etc.). Remove any interference. 2. Check to see if cables are attached properly to the couplings and gear cases. Tighten set screws if required.
Microscope interference.	<p>Remote Adjust Inkers are designed to be used with the following microscopes:</p> <ul style="list-style-type: none"> •EG3100, EG3110 and EG3200 = Optem HF-65 with 0.7X-4.5X Objective Lens. Min. Working Distance = 90mm (3.50") or Olympus SZ series with 0.3X or 0.4X Objective Lens. Min. Working Distance = 210mm (8.27") <p>If you are using a model other than these contact Xandex.</p>
The inker is working intermittently from the outset.	<ol style="list-style-type: none"> 1. Incorrect inker drive, in which case the plunger will travel very sluggishly. The 300Ω coil on the Remote Adjust Inker requires an inker drive signal of 48 volts with a 25 ms pulse duration. See "Inker Drive Verification" later in this Section (6). 2. The plunger might be bent. This can happen when pushing the plunger through the coil. Manually actuate the plunger a few times, rotate 1/4 turn and repeat. The plunger should travel freely. Replace if necessary.

Problem:	Solution:
The inker is working intermittently from the outset (continued)	<ol style="list-style-type: none"> 3. During opening of the cartridge, the fishline monofilament has been kinked because the main shaft was lowered quickly or incorrectly. Replace the cartridge. See Section 4 “Priming the Cartridge.” 4. Faulty electrical connection somewhere on the line. Check the continuity of electrical supply connections to the inker and correct as necessary.
The inker works fine for awhile (4-8 hours), then starts to skip badly.	<ol style="list-style-type: none"> 1. Ink flow channels are blocked by the lower O-ring. If the bottom O-ring is not lifted during opening and priming, a small amount of ink below will be used up after a few rows, while the remainder is trapped in the reservoir. Remove the cartridge, close and repeat opening and priming procedure in Section 4. 2. When the cartridge is installed on the holder, the indicators are left aligned instead of moved 1/4 turn into locking position, and the main shaft has been pushed closed. Remove the cartridge and repeat opening and priming procedure in Section 4. 3. Wrong inker drive being used. Sometimes the coil problem does not appear from the outset. If the actuation pulse is marginally acceptable, as the solenoid heats up the plunger will travel less than a full stroke. This causes the inker to miss badly. See “Inker Drive Verification” in this Section (6) to check inker drive, pulse width, and cycle time.
Inker X/Y travel does not permit inking in the center of the Die.	<ol style="list-style-type: none"> 1. Verify the test head is co-planar with the ring carrier. If it is not, this will effect the X/Y position of the inker. Shimming the test head to achieve planarity may be required. 2. Verify that the inker is mounted properly on the mounting ring adapter. 3. Verify that the ink cartridge is "snapped" all the way into the holder. Support the back edge of the holder with your index finger and press the cartridge back with your thumb until it snaps all the way into the clip holder "tongs" on the holder.

Problem:	Solution:
<p>Inker X/Y travel does not permit inking in the center of the Die (continued)</p> <div style="text-align: center;">  <p>DO NOT BEND THE CARTRIDGE NEEDLE!</p> </div>	<ol style="list-style-type: none"> 4. Visually examine the installation to insure that there is no interference between the inker body tube and any portion of the test head. 5. Remove the inker and check the cartridge. Cartridges are manufactured to a $\pm 2^\circ$ tolerance. Rotating the cartridge 90° or 180° (depending on whether you are off center in the X or Y direction) should solve your inability to ink in the center of a die.

Inker Drive Verification

Xandex inkers operate nominally across all common prober circuits. If inker performance is not acceptable, it may be due to incorrect inker drive. The 290Ω coil used in the remote adjust inker solenoid requires a minimum of 48VDC for consistent solenoid actuation. Verify that the inker drive output signal is ≥48VDC by connecting an oscilloscope to the prober inker connection and actuating the inker several times. If the drive voltage is less than 48VDC consult your prober manufacturer for prober inker drive voltage modification procedure. If the voltage is ≥48VDC and acceptable results are still not achieved, the drive signal may be analyzed using the procedure below.

Referring to the prober manual, install a 2Ω 10 watt resistor in series with the inker solenoid as shown below:

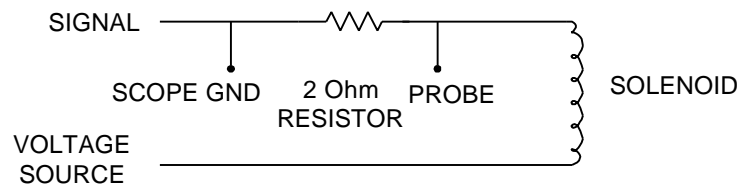

Using an oscilloscope, connect a probe as shown above and measure the arrival time of the solenoid. Set the time scale to 5 ms per division and the voltage to 1 mV per division. Fire the inker several times and look for the following trace.

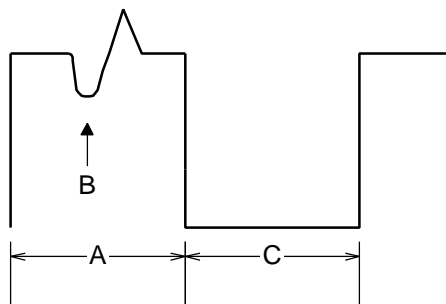

- A = On time of inker pulse.
- B = Solenoid arrival point. This indicates that the plunger has bottomed out in the coil.
- C = Off time of inker cycle.

“B” is the critical component of this waveform. It is the visual indication that the plunger has traveled its full stroke. If the “kick” is not visible, or if it moves off the right side of the trace to a point beyond the falling edge, adjustment to the prober inker drive circuit is required.

COIL RESISTANCE	MINIMUM DRIVE VDC	COLD ARRIVAL TIME	HOT ARRIVAL TIME
290 Ω (±10Ω)	48VDC	15-18 ms	20-24 ms

To verify the inker drive circuitry, perform a minimum of 5 test cycles with each cycle consisting of 2 minutes of constant inking using “Typical Drive Voltage” with a 25 ms pulse width and a 30 second rest period between cycles. The “Cold Arrival” times are measured during the 1st cycle and the “Hot Arrival” times are measured during the 5th cycle.

If arrival times are acceptable, no further change is required. If the current configuration is inadequate, increase the drive pulse width to 30 ms. If this still does not provide acceptable operation, increase the inker drive voltage by 20% and decrease the pulse width by 25%.

If acceptable results are still not achieved, contact Xandex Customer Service for assistance.

Section 7. EG3000 Series Options

EG3000 Series Options

An Ink Dot Counter Box is available for the EG3000 Series, which can be easily connected between the inker and the prober. This allows tabulation of a running dot count to assess inker and cartridge use. Specifications and installation instructions are listed below.

Order Part No. 350-0003 for connection to EG probers and Part No. 350-0008 for connection to KLA probers.

Ink Dot Counter Box Specifications

Size:	2.5" Cube (63.5mm)
Weight:	5.6 Oz (0.16kg)
Power Consumption:	15mA typical @ 60V input, 100% duty cycle
Input Level:	12V - 60V
Count Speed:	100 counts/second maximum, with minimum 5 ms on time, 5 ms pause between pulses
Input Cable:	36" nominal with various connectors depending on unit configuration
Output Level:	Parallel to input, 100% of input signal level is reflected to output
Counter:	6 digit LCD, 0.2" high, powered by a lithium battery with a 10 year shelf life.
Operating Temperature:	-30°C to +75°C (-22°F to +167°F)

Installation

Disconnect the inker from the prober jack and plug it into the connector on the back of the Counter Box. Plug the Counter Box cable into the appropriate inker driver connection on the prober. The Counter Box is now installed and ready to run. To clear the counter display, press the round red button on the display.

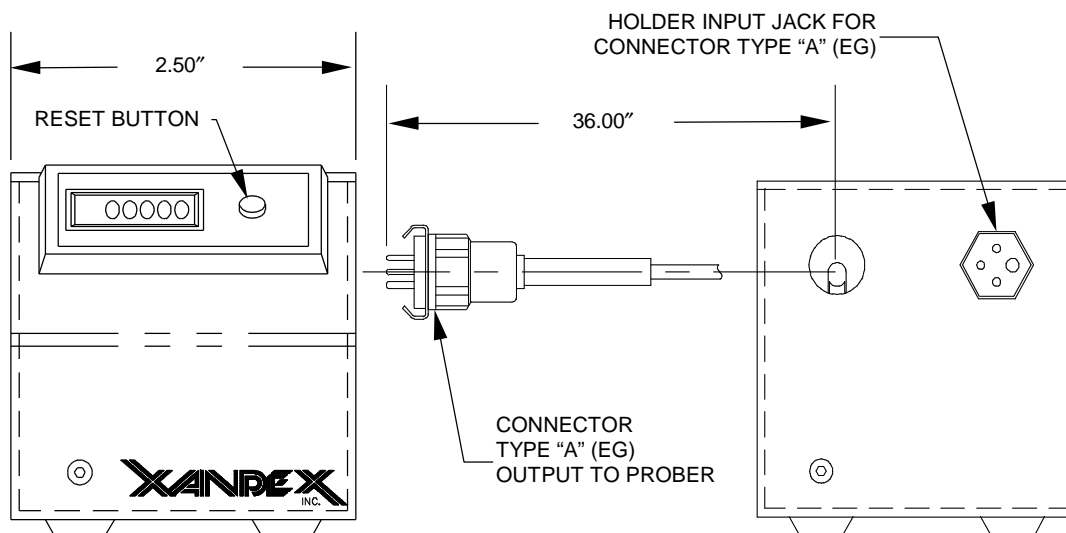

EG3000 Series Options

A Remote Adjust Rack Kit is available for the EG3000 series for safely storing the inker when removed from the test head. The Remote Adjust Rack Kit supports and surrounds the inker body and cartridge with a sturdy aluminum tube for added protection when the inker must be removed from the test head during docking and undocking.

This kit accommodates both electric and pneumatic Xandex remote adjust inkers with up to a 3.25" diameter and 15" length (mounting surface to cartridge tip) and includes mounting hardware and a synch strap for versatile "mount anywhere" positioning.

Order Part No. 220-0044.

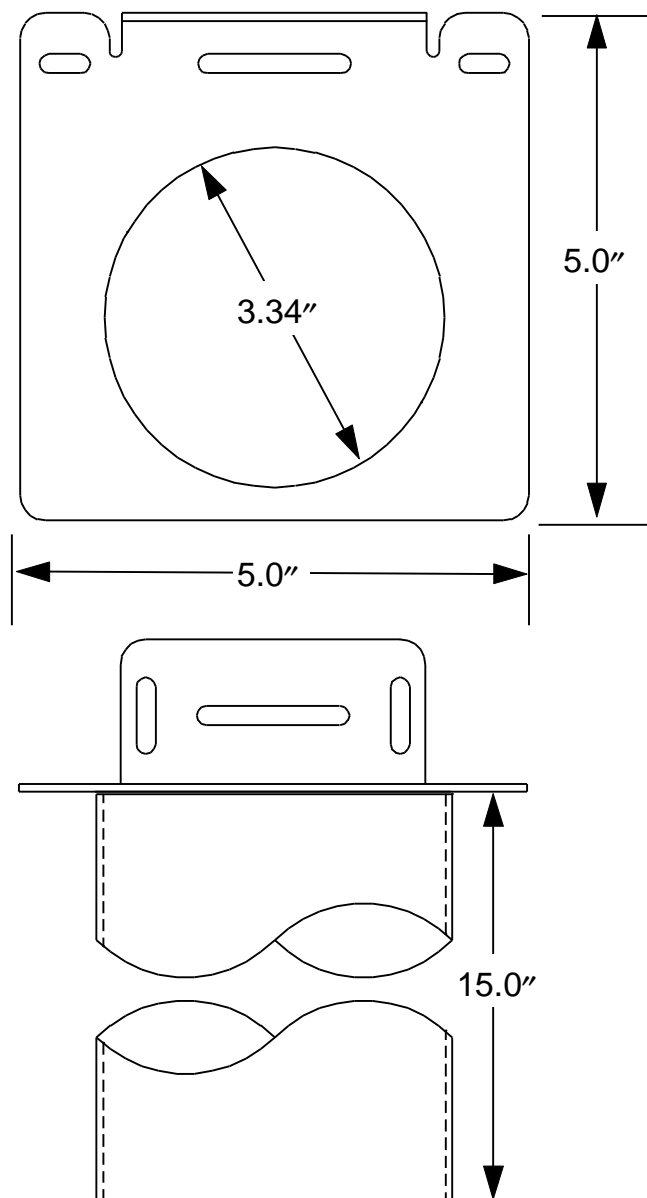

Section 8. System Specifications

EG3100 Electric Remote Adjust Specifications

Size:	Tube diameter 2.95" x 11.5" H (1" Pogo Pins), 12" H (1.5 Pogo Pins)
Inker Drive Input:	48 volts @ 25 ms pulse duration
X & Y Travel:	± 0.060" (± 1.52mm)
Z Travel:	± 0.125" (± 3.18mm)

Ink Cartridge Specifications

Cartridge dot production and dot size are influenced by many factors, including inker drive, coil voltage, ambient temperature and ink type. The following figures are average dot quantities for the cartridge types listed and are based on complete use within cartridge open shelf life periods of 5 days maximum for Markem® 6990, 6993, 6997 and Xandex 8103 inks and 3 days maximum for Xandex 7824 and 7824T inks. Testing was performed under controlled, optimum laboratory conditions on unetched wafers. These figures are meant for use as guidelines and as such, cannot be guaranteed.

DieMark [®] Filament Cartridge Average Dot Production			
Type	# of Dots	Type	# of Dots
8 mil	325,000 dots	25 mil	60,000 dots
10 mil	250,000 dots	28 mil	30,000 dots
15 mil	175,000 dots	30 mil	15,000 dots
20 mil	125,000 dots		

Cartridge Model	Exposed Needle Length	Available Inks	Cartridge Type
DM-1	0.75"	Markem [®] 6990, 6993, 6997, Xandex 7824, 7824T Xandex 8103	08 mil 10 mil 15 mil 20 mil* 25 mil✓ 28 mil** 30 mil***

*Not available in 7824, 7824T or 8103

**Not available in 6990 or 8103

*** Not available in 7824T black

✓ Not available in 8103

Seller warrants as follows:

All material supplied will conform to the description stated.

All products will be free of defects in materials and workmanship under normal use for the following periods:

1. Stated shelf life of Inker Cartridges:
 - ◆ Markem[®] 6990, 6993 6997 and Xandex 8103 = Four (4) months. Five (5) days after cartridge opening.
 - ◆ Xandex 7824 and 7824T = Two (2) months. Three (3) days after cartridge opening.
2. Ninety (90) days from the date of delivery to the customer for all other products.

SELLER MAKES NO OTHER WARRANTY, EXPRESS OR IMPLIED, INCLUDING WITHOUT LIMITATION ANY WARRANTY OF MERCHANTABILITY OR OF FITNESS. IT SHALL BE AT SELLER'S OPTION TO HAVE THE DEFECTIVE PRODUCT REPAIRED OR REPLACED, OR TO GRANT A REFUND OF THE PURCHASE PRICE.

3. Seller, upon request, may furnish to Buyer such technical advice as it may be able to supply with reference to the use by Buyer of any material delivered hereunder. Seller, however, assumes no obligation or liability for the advice given or results obtained. Buyer expressly agrees that it will implement any advice thus given at its own risk and agrees to indemnify and hold harmless against any liabilities, costs, or expense resulting there from.
4. Xandex makes no warranty for performance, service or support of any products purchased into the following territories unless purchased directly through an authorized Xandex distributor; Austria, Belgium, Denmark, Finland, France, Germany, Hong Kong, Italy, Japan, Korea, Malaysia, Netherlands, Norway, Philippines, Singapore, Sweden, Switzerland, Taiwan, Thailand and the UK.
5. If you have any questions or need further assistance please call, fax or write:



Customer Service

1125 N. McDowell Blvd.

Petaluma, California 94954 U.S.A.

Toll Free in the United States (800) 767-9543

or (707) 763-7799 FAX (707) 763-2631

www.xandex.com

email: info@xandex.com

Description	Drawing Number
Inker Assembly, Model EG3100	320-3101
	1 of 2
Bill of Materials	2 of 2
Inker Assembly, Model EG3200	320-3201
	1 of 2
Bill of Materials	2 of 2
O.D. Model EG3100	900-0139
	1 of 2
	2 of 2
Adapter Ring Assembly, Trillium RA	220-0010
	1 of 2
Bill of Materials	2 of 2
Inker Kit EG3100	331-3100
	1 of 2
Bill of Materials	2 of 2
Inker Kit EG3110	331-3110
	1 of 2
Bill of Materials	2 of 2
Inker Kit EG3200	331-3200
	1 of 2
Bill of Materials	2 of 2

This page is intentionally left blank.