

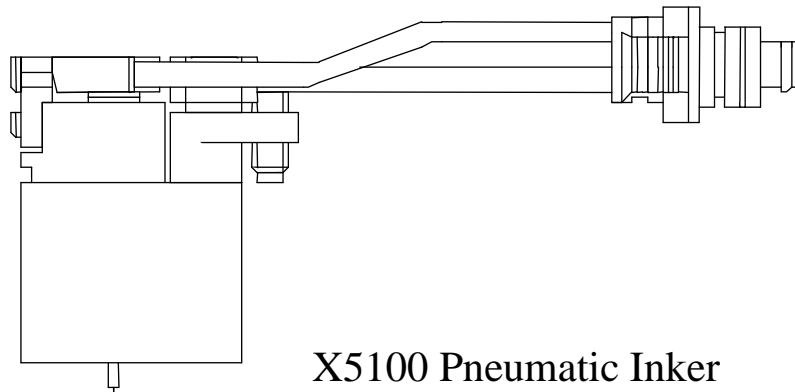

X5100 SERIES PNEUMATIC INKER INSTALLATION AND OPERATION MANUAL

820-0033 Revision Y
January, 2017



X5100 Pneumatic Inker



SERVICE AND SUPPORT INFORMATION



1360 Redwood Way, Suite A
Petaluma, CA 94954

Telephone: (707) 763-7799
OR (800) 767-9543

FAX: (707) 763-2631
Internet: www.xandexsemi.com
Email: info@xandex.com

International Distributors

China

PREMTEK HOLDING CO. LTD. (Shanghai)

2F, No.1077
ZuChongZhi Rd
Zhang Jiang Hi-Tech Park
PuDong New Area
Shanghai 201203
Peoples Republic of China
Telephone: 86-21-50275859
Fax: 86-21-50275877
Contact: Jason Huang
Email: ptis@premtek.com.cn
Website: www.premtek.com.tw

Japan

HUGLE ELECTRONICS, INC.

4-5-7 Iidabashi,
Chiyoda-Ku
Tokyo, Japan 102-0072
Telephone: (81) 3.3263.6661
Fax: (81) 3.3263.6668
Email: INB@hugle.co.jp
Website: www.hugle.co.jp

Korea

HUGLE ELECTRONICS, INC.

Br. Office: 2FL Hugle Bldg.
86-14 Garak-Dong, Songpa-Ku
Seoul, Korea 138-803
Telephone: +82 (02) 431-7477
Fax: +82 (02) 449-6295
Email: hugle@hugle.co.kr
Website: www.hugle.co.kr

Taiwan





PREMTEK INTERNATIONAL





4F, No. 47, Lane 2, Kuang-Fu Road
Sec 2, Hsinchu City
Taiwan R.O.C.
Telephone: (886) 35.722000
Fax: (886) 35.725000
Email: pji@premtek.com.tw
Website: www.premtek.com.tw



SAFETY INFORMATION

Safety and Hazard identification symbols used in this document are intended to be compliant with ANSI/NEMA Z 535.6 2006. The table below lists the symbols used in this document along with a description of each type of safety hazard. Failure to observe identified safety risks may result in serious injury or death.

Safety and Hazard Identification Symbols

SYMBOL	DESCRIPTION
	DANGER = Indicates a hazardous situation which, if not avoided, will result in death or serious injury
	WARNING = Indicates a hazardous situation which, if not avoided, could result in death or serious injury.
	CAUTION = Indicates a hazardous situation which, if not avoided, could result in minor or moderate injury.
	NOTICE = Indicates a practice that is not related to personal injury, but may cause damage to equipment or property.

	<i>Use this product only in the manner described in this manual. If the equipment is used in a manner not specified by the manufacturer, the protection provided by the equipment may be impaired.</i>
	<i>Install the pneumatic controller in a location that is easily accessible to the operator. The ON/OFF switch is the pneumatic controller's main disconnecting device and must be easily accessible at all times.</i>
	<i>For your safety, the AC power cord set provided with your product has a grounded plug. Always use the power cord with a properly grounded wall outlet, to avoid the risk of electrical shock.</i>
	<i>Do not operate this product with a damaged AC power cord set. If the AC power cord set is damaged in any manner, replace it immediately. Damaged cords may result in user exposure to hazards.</i>

	<p><i>The power cord set received with the product meets the requirements for use in the country where you purchased the equipment. Use only the power cord provided with the unit or an authorized replacement power cord from Xandex Inc. or an approved Xandex distributor. Use of an inadequately rated power cord may result in shock or injury.</i></p>
	<p><i>Do not operate this product with a damaged DC power supply. If the DC power supply is damaged in any manner, replace it immediately. A damaged DC power supply may result in user exposure to hazards.</i></p>
	<p><i>The DC power supply received with the product meets the requirements for use in the country where you purchased the equipment. Use only the DC power supply provided with the unit or an authorized replacement power supply from Xandex Inc. or an approved Xandex distributor. Use of an inadequately rated power supply may result in shock or injury.</i></p>

CONTROLLER REDESIGN

Xandex DieMark[®] pneumatic controllers with serial numbers 4000 and higher represent a new design that replaces the controller’s internal AC/DC transformer with a new, external AC/DC power supply.

This manual revision documents the new controller design with external power supply.

If you have a pneumatic controller with a direct AC input, please go to the product manuals section of the Xandex Semiconductor Products website at www.xandexsemi.com to locate the manual for your controller model.

The new controller design utilizes different pneumatic valves than previous controllers. Due to this change two new controller preventive maintenance sets have been released. See **Controller Maintenance in Section 6** for details.

No change has been made to the Inker assembly or the way it operates and connects to the pneumatic controller. Inker assemblies can be used interchangeably with new and old controller versions. Please note that in order to obtain your desired dot size, you may have to adjust dot size thumbwheel settings when using an inker with a different controller.

Please contact [Xandex Customer Service](#) with any questions regarding this design change or any other feature of your Xandex DieMark Inking System.

Table Of Contents

Section 1. Introduction.....	1-1
Theory of Operation.....	1-1
Section 2. System Overview.....	2-1
System Components.....	2-1
Section 3. Installation.....	3-1
X5100 Inker Installation.....	3-1
Controller Installation.....	3-3
Section 4. System Operation.....	4-1
Controller Operation.....	4-1
Ink Cartridge.....	4-6
Cartridge Priming and Use Tips.....	4-9
Ink Cartridge Labeling.....	4-10
Cartridge Type Label Color Coding.....	4-11
Inker Assembly Setup & Alignment.....	4-11
Section 5. Ink.....	5-1
General Information.....	5-1
Ink Curing.....	5-2
Ink Removal Information.....	5-3
Section 6. Maintenance & Troubleshooting.....	6-1
Ink Troubleshooting.....	6-1
Inker Troubleshooting.....	6-3
Shuttle Maintenance.....	6-5
Pneumatic Controller.....	6-8
Controller Diagnostics.....	6-9
Controller Troubleshooting.....	6-11
Internal Maintenance.....	6-13
Preventive Maintenance.....	6-15
Valve Replacement.....	6-16
Section 7. System Specifications.....	7-1

DC Power Supply Requirements	7-1
Pneumatic Controller Specifications.....	7-1
Ink Cartridge Specifications	7-3
Cartridge Availability	7-3
Inker Warranty	7-4
System Drawings	7-5

Section 1. Introduction

Theory of Operation

The X5100 Pneumatic off-line or post probe inker is designed for use on the Electroglas Horizon Series 4080/4090 prober. The innovative X5100 is designed to fit in the prober's optical channel with minimal protrusion above the ring carrier, making it perfect for overhead testing applications since it provides sufficient test head clearance.

The X5100 incorporates the convenience of DieMark™ cartridges with the reliability of a microprocessor-controlled pneumatic dispensing system for the ultimate inking solution.

Ink dots are deposited via pneumatic actuation of the inker shuttle mechanism and a simultaneous pulse of air into the cartridge reservoir. There is no filament and no direct contact with the wafer surface. A prober signal to the controller initiates the inking sequence, actuating the shuttle mechanism downward and sending an air pulse to the cartridge.

As the shuttle extends to the downward position, the air pulse to the cartridge forces ink out of the cartridge barrel and forms a drop at the end of the needle tip. When the shuttle is at its lowest position, the drop makes contact with the wafer surface and forms a dot.

After 23.3 milliseconds the shuttle returns to the normal position. After completion of each dot, a small amount of vacuum is developed in the cartridge by the closure of the valve, causing the ink to back up into the cartridge reservoir, preventing dripping.

If another dot sequence is not initiated within 10 seconds, a "puff" pulse of air that varies with the dot size setting duration (6.75 - 13.15ms) will displace a small amount of ink back into the Teflon® tube to aid in maintaining proper dot size after long delays between dots.

The dot size is determined by cartridge air pulse duration. Adjust the controller setting to change the dot size - without changing the cartridge. Pneumatic cartridges are factory tuned, ensuring consistent dots and contain 40% more ink than standard DieMark™ cartridges.

Thank you for selecting ...  ...as your inking choice.

Please spend a few minutes familiarizing yourself with the unit. Most questions you may have will be answered in this manual. If you would like further assistance, please contact your local Xandex distributor or call us at (707) 763-7799 or Toll Free in the U.S: (800) 767-9543. FAX (707) 763-2631. For more information about Xandex and our complete line of quality inking and interfacing products, visit us on the Internet at <http://www.xandexsemi.com/> or email: us at <mailto:info@xandex.com>.

This page is intentionally left blank.

Section 2. System Overview

System Components

Set Part No. 340-5100 (Model X5100)

1. Pneumatic Inker Assembly
Model X5100 Part No. 320-5100
2. Regulator Assembly Part No. 220-0076
3. Air Hose Regulator > Controller Part No. 210-2001
4. Cartridge Opening Tool Part No. 110-1001
5. Cable/Connector Assembly Type AC Part No. 210-0109
6. Pneumatic Controller Part No. 350-0002
(*Includes ONE AC Power Cord-Item 8)
7. 24VDC Power Supply Part No. 159-0048
8. A. AC Power Cord (USA)* Part No. 158-0051
B. AC Power Cord (Europe)* Part No. 158-0407
C. AC Power Cord (UK)* Part No. 158-0408
D. AC Power Cord (PSE-Japan)* Part No. 158-0727

*One power cord is shipped with each set and must be specified at ordering.

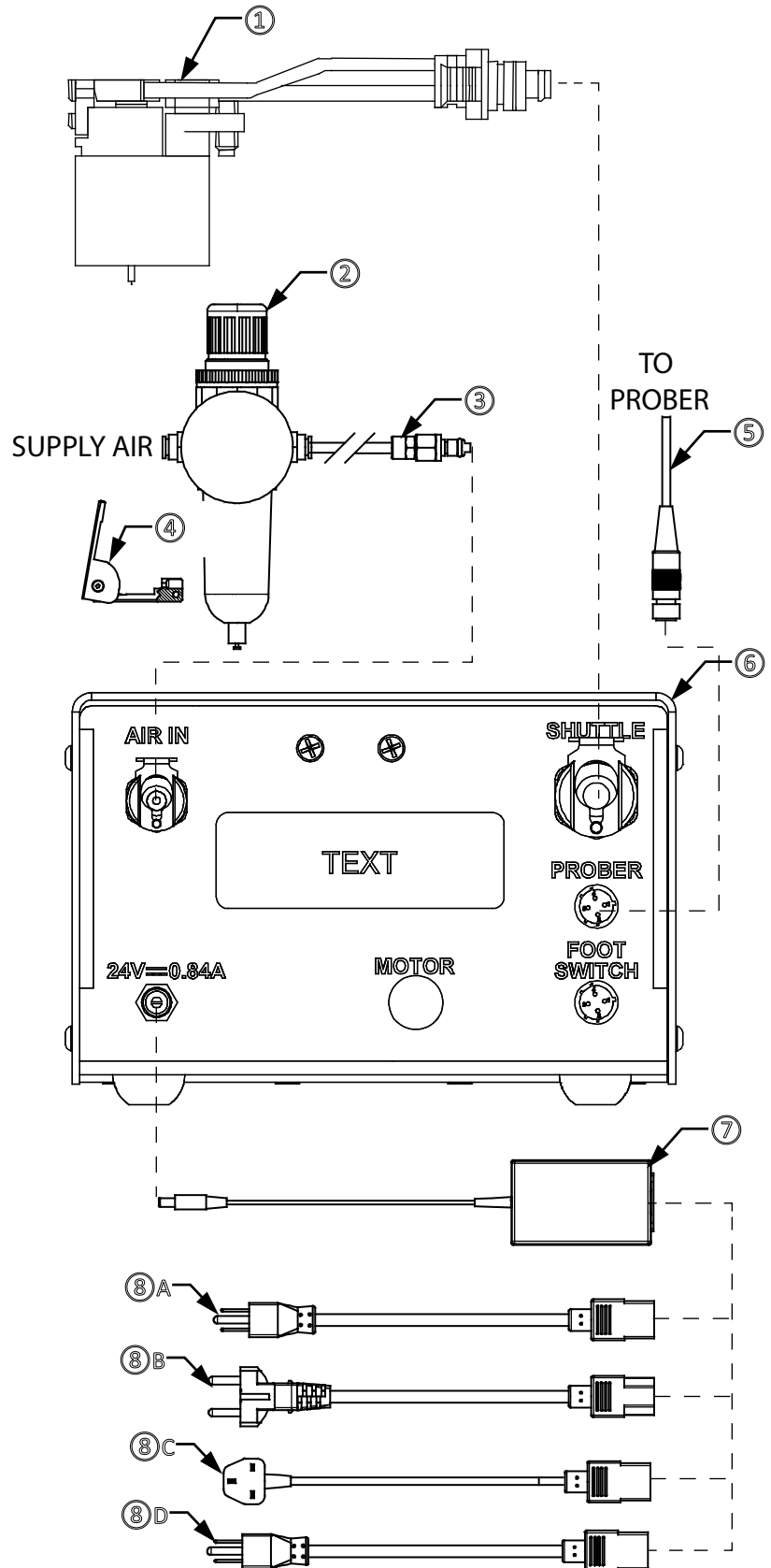

This page is intentionally left blank.

Section 3. Installation

X5100 Inker Installation

The Xandex model X5100 Inker installs into the existing inker aperture located on the EG optical channel (Part No. 252884).

1. If you are currently using the Electroglas inker assembly P1-1100, remove it from the optical channel.

NOTICE

Move the chuck/wafer from underneath the inker when installing inker to prevent damage.

2. Make sure the dowel pin and set screw are installed in the inker mounting aperture. If not, they are supplied with the Xandex X5100 inker (P/N 508-0007 & 510-6408) and should be installed at this time.
3. Using an Allen wrench, turn the Z Adjustment screw counter-clockwise to lower the inker Z height. The Z Height adjustment screw on the Inker should be set in a low position.

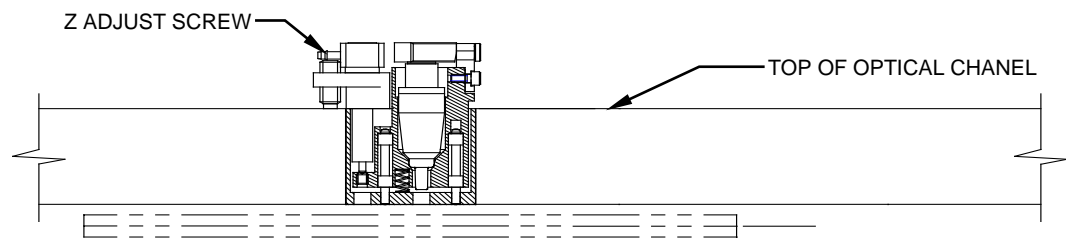

4. Insert the inker into the aperture, oriented as shown, routing the air hose towards the rear of the prober. The Z Adjustment screw will support the inker.

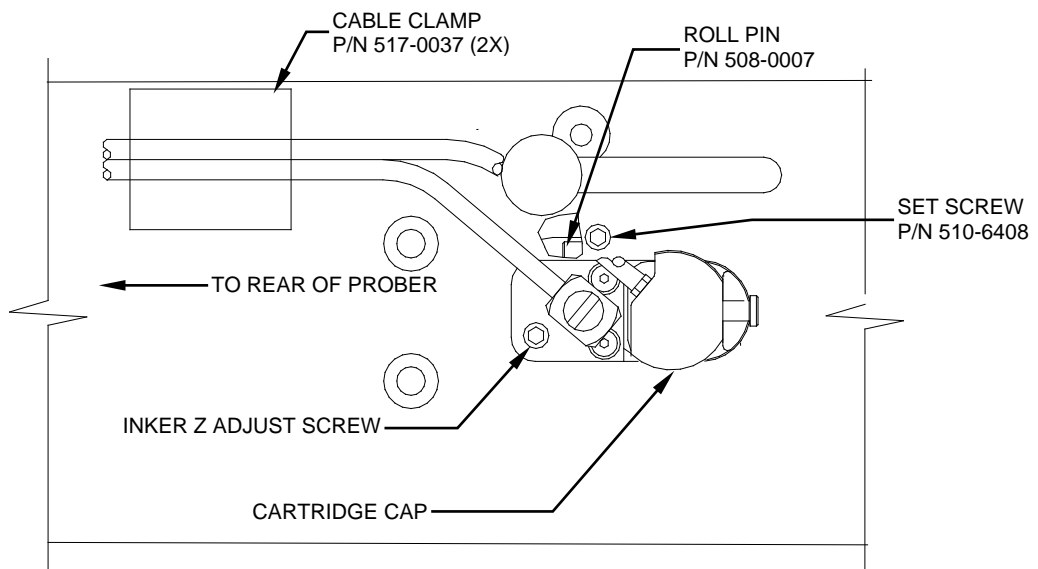

5. Lock the inker into place in the optical channel using the dowel pin/set screw.

6. Secure the air hose to the surface of the optical channel with the 2 supplied cable clamps.
7. Proceed to the **“Controller Installation”** portion of this Installation Section (3), and install the pneumatic controller per instructions for your application.
8. With the controller installed, connect the fitting on the *controller-to-shuttle air hose* into the connection on the rear of the pneumatic controller labeled **“SHUTTLE”**.
9. Proceed to **Section 4 “System Operation”** for ink cartridge installation, inker setup, alignment and controller operation instructions.

Controller Installation

1. Remove the bracket from the regulator/filter assembly by removing the plastic retaining nut. Mount the regulator/filter bracket in a convenient location (mounting screws are not supplied). The regulator can be mounted to the bracket with the supplied nut after the bracket is installed.

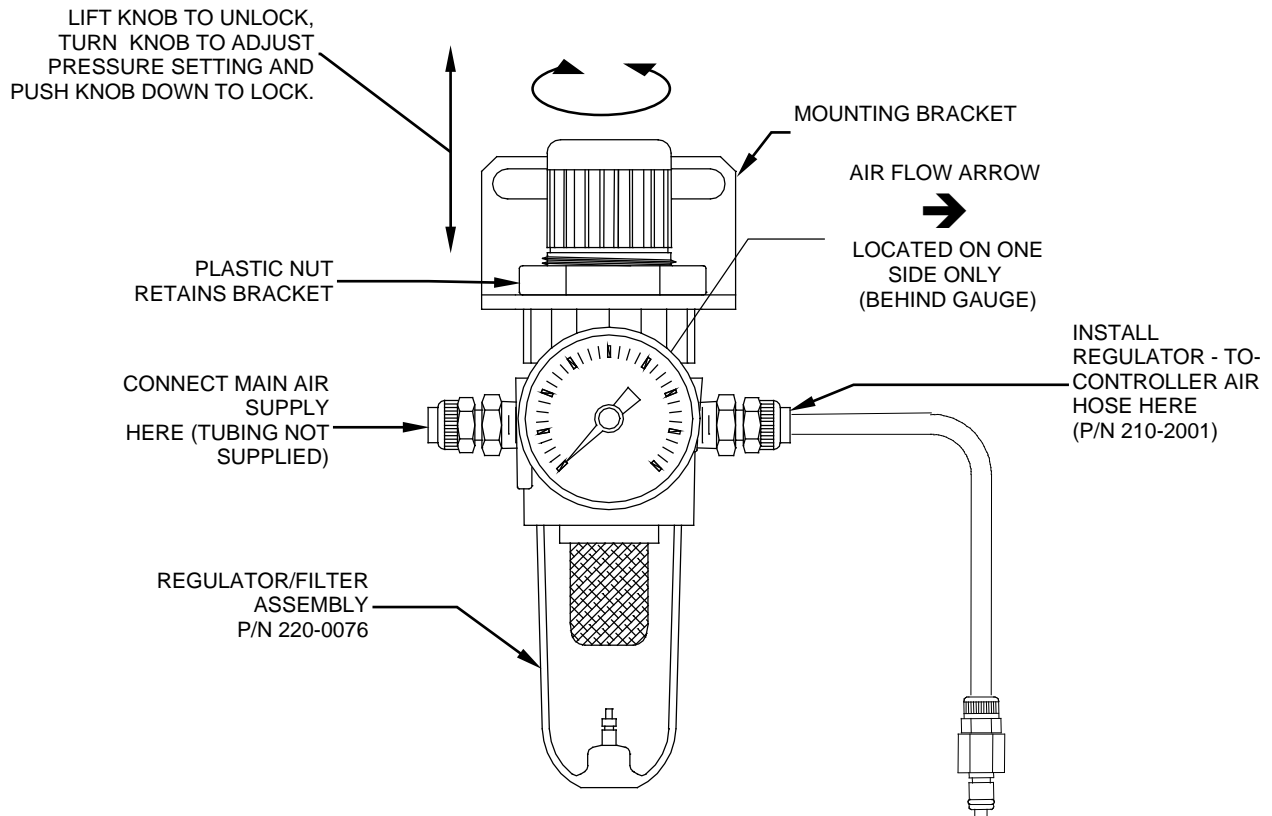

2. Install 1/4 O.D. x 0.170 I.D. polyethylene tubing (not supplied) to the main air source and then connect to the input fitting on the regulator. (The left side when facing the gauge.)
3. Connect the *regulator-to-pneumatic controller air hose* (P/N 210-2001 supplied) to the *output fitting* on the regulator. (The right side when facing the gauge.)

Note: The *regulator-to-pneumatic controller air hose* supplied by Xandex, is 6 feet long. If the distance (hose length) requirement exceeds this length, use 1/4 O.D. x 0.170 I.D. polyethylene tubing.

4. Plug the *regulator-to-controller air hose* into the *small* "AIR IN" connection on the rear of controller.

Note: *The air hose connectors are spring locked. If the air hose connectors do not insert easily, make sure the spring lock is in the open position by pushing the metal snap-lock down until it clicks.*

5. Turn on the main air and adjust the regulator until it reads 70 ± 10 PSI on the dial. To make regulator adjustments, pull up on the knob on the top of the regulator to unlock, then rotate the knob clockwise to increase or counter-clockwise to decrease. Push down on the knob after adjustment to lock it into position.
6. Check all connections for air leaks. If required, turn off the main air and make necessary repairs.
7. Install the *cable/connector* (P/N 210-0109) to the inker port on the prober and the "PROBER" connector on the rear of the controller unit.
8. Move the toggle switch on front of the controller to "RUN" (mid) position.
9. Install the *AC power cord* into the back of the power supply. Connect the power supply cord to the 24V-.84A socket on the back of the controller. Plug the AC power cord into an AC supply outlet. Turn the ON/OFF switch on the front of the controller to ON. At this point, the "INK ON" LED will flash once, while the "STATUS" LED will stay on. Proceed to **Section 4 "System Operation"** for ink cartridge installation, inker setup, alignment and controller operation instructions.

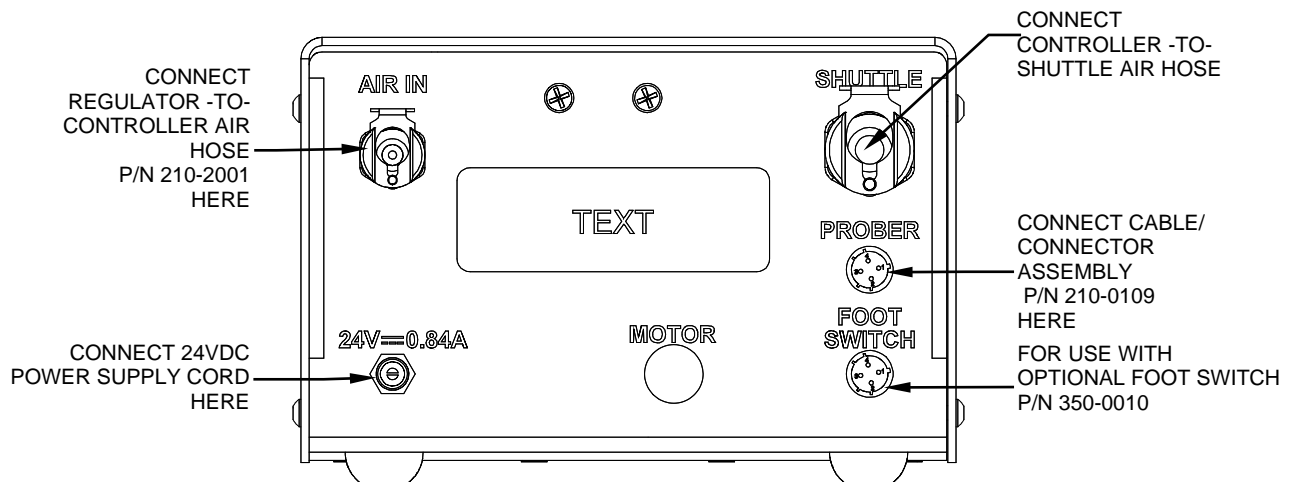

Section 4. System Operation

Controller Operation

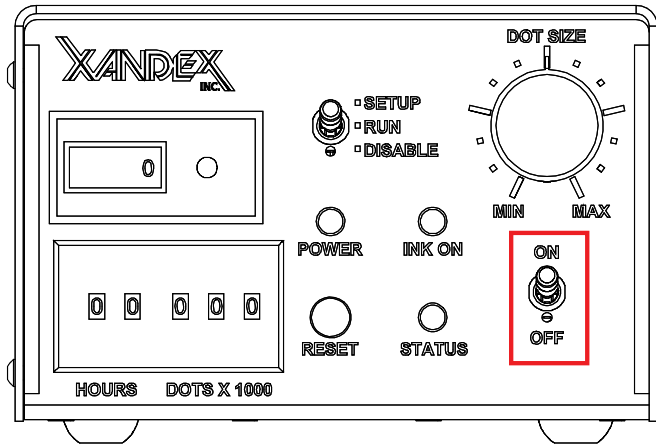

FRONT VIEW

ON-OFF Switch: The ON/OFF switch turns power to the controller ON and OFF.



Install the pneumatic controller in a location that is easily accessible to the operator. The ON/OFF switch is the pneumatic controller's main disconnecting device and must be easily accessible at all times.

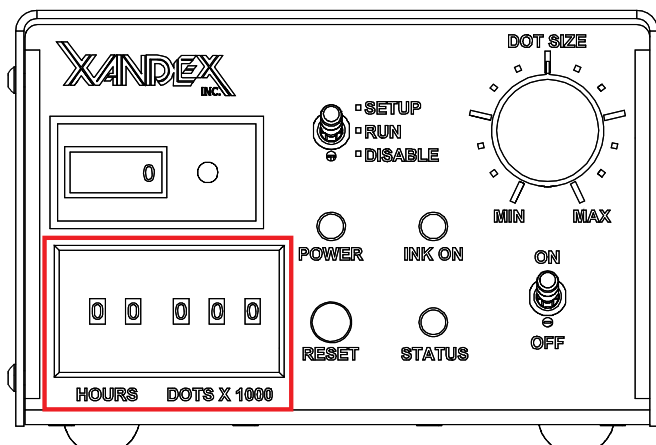

Programmable Thumbwheel Counter: Individual thumbwheel settings are available to monitor either the number of dots, the number of hours of operation, or both. The first two thumbwheels on the left are for monitoring the number of hours, with a maximum setting of 99 hours. The next three thumbwheels are for monitoring the number of dots produced, with a maximum setting of 999,999 dots. The red "STATUS" LED will be illuminated when either of the programmed limits is exceeded.

To set the limits, make sure the controller has power, adjust the thumbwheels to the desired setting and press the RESET button twice (within 5 seconds). To set for hours only, set the HOURS thumbwheels to the desired value and the DOTS X1000 thumbwheels to 000. To set the limits for the number of dots only, set the DOTS X1000 thumbwheels to the desired value and the HOURS thumbwheels to 00. To use both limits, set each thumbwheel to the desired values. Both settings are monitored and stored in RAM in the microprocessor and are not battery backed-up. The first setting to be reached will illuminate the STATUS LED*.

HOURS	DOTS X 1000	REACTION
Set	000	"STATUS" LED is lit when "HOURS" set point is reached . For example, if you set the "HOURS" thumbwheel to 24, the "STATUS" LED will turn on when 24 hours of operation are complete.
00	Set	"STATUS" LED is lit when dot count set point is reached. For example, if you select 30,000 dots (turning the "DOTS X 1000" thumbwheel to 30) the "STATUS" LED will light when 30,000 dots have been deposited.
Set	Set	"STATUS" LED is lit when 1st set point is reached, regardless if it is hours or dot count.
00	000	"STATUS" LED will not light up (inactive). Feature not invoked.

* If controller internal audio alarm is enabled, alarm will sound in addition to the STATUS LED when DOTS X1000 set point is reached (no audio alarm for HOURS set point). See Section 6. Maintenance and Troubleshooting for information on enabling the audio alarm. This feature is only available on controllers shipped after June, 2006.

NOTICE	<p><i>The programmed set points (number of dots or hours) and their associated counters are stored in volatile memory (RAM). If power is lost, the set points will be lost and must be re-programmed using the RESET button after power is restored.</i></p>
---------------	--

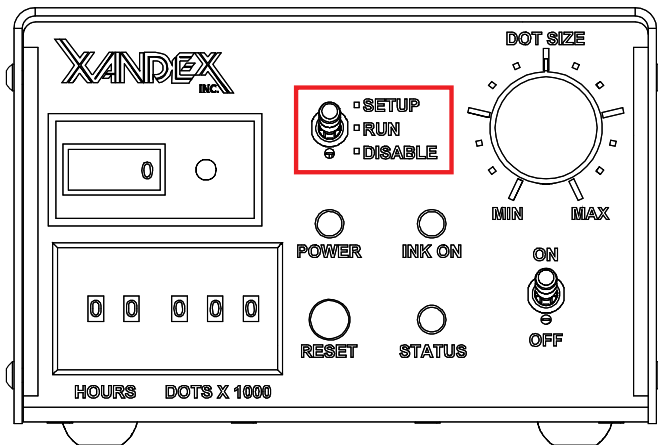

Mode Selection Switch: A three position toggle switch is located on the front panel for selecting different operating modes.

- SETUP = Shuttle air valve (V2) is enabled
- RUN = Normal operation
- DISABLE = Shuttle air valve (V2) is disabled

When placed in the "SET-UP" position, the shuttle air valve (V2) is enabled, moving the shuttle to its lowest position for Z set-up adjustment. While in the "SET-UP" mode, perform coarse Z height adjustment as described in the Set-Up and Alignment procedure later in this section (4).

After five minutes in the "SET-UP" mode, the microprocessor will disable the shuttle air valve, returning the shuttle to the normal position. If set-up was not completed, return the switch to the "RUN" position, then back to "SET-UP". In the "RUN" position, the system operates normally. When the toggle switch is placed in the "DISABLE" position, the shuttle air valve (V2) is disabled and the shuttle does not extend during inking. This mode is used in hand-inking applications with the optional foot switch.

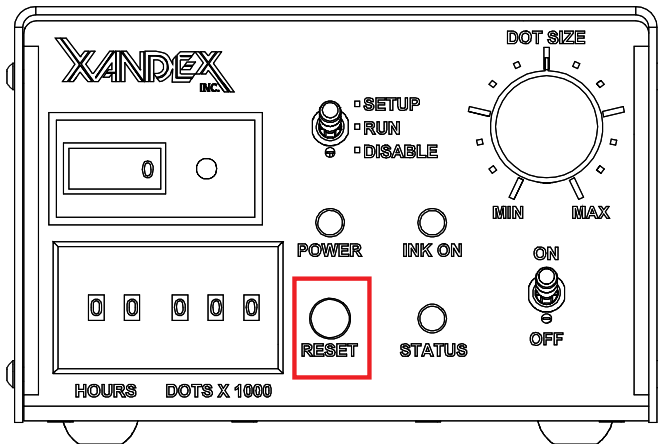

Reset Button: A "RESET" button is located to the right of the thumbwheels for resetting the counters in the microprocessor. When the "RESET" button is depressed once, the "STATUS" LED will flash for 5 seconds. If it is pressed a second time during the 5 second period, the controller will "read" the setting on the thumbwheel switches and load those values into the microprocessor. If the "RESET"

button is not pressed a second time and the 5 second flash time is exceeded, the "STATUS" LED will stop flashing and the current timer set points and internal counts will not be changed. The "RESET" button is also used to enter the diagnostic mode when power is applied to the controller with the "RESET" button depressed. For details and descriptions of controller diagnostic tests see **“Controller Diagnostics”** in **Section 6**.

<div data-bbox="300 1033 600 1119" data-label="Section-Header"> <p>NOTICE</p> </div>	<p>If the prober is running and the "RESET" button is pushed, the "INK ON" LED will flash intermittently. After 5 seconds, the "INK ON" LED will stop flashing and the unit will continue with the current programming. If the prober is running and the "RESET" button is depressed a second time within the 5 second reset time, INPUT SIGNALS FROM THE PROBER WILL BE INHIBITED AND THE UNIT WILL RESET AND RE-PROGRAM ITSELF.</p>
---	--

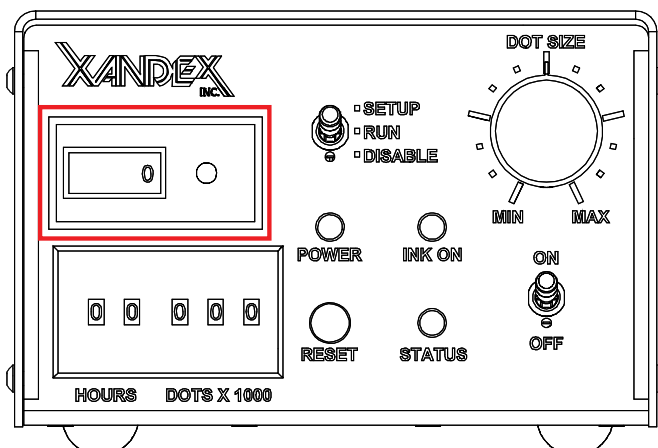

Dot Counter: A separate LCD "DOT COUNTER" is located on the front panel above the thumbwheels. The LCD "DOT COUNTER" gives a real time read out of the number of dots deposited. The counter has an internal Lithium battery with a nominal life of 10 years. Pressing the small red reset button next to the "DOT COUNTER" LCD window resets the counter display only. It will have no effect on the programmed

counter circuits within the microprocessor. Reset the counter when a new ink cartridge is installed to record the numbers of dots produced by that cartridge.

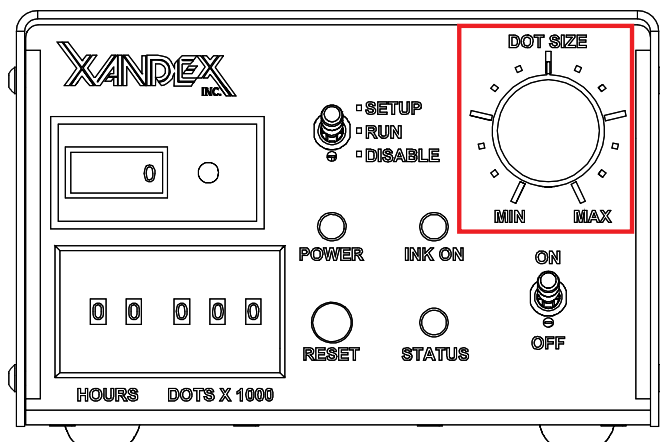

Adjustable Dot Size: The adjustable "DOT SIZE KNOB" on the front panel is used to vary the size of the dot produced without changing cartridges, affecting set-up or requiring additional operator steps. The microprocessor reads the knob position and outputs a signal to enable the associated air valve for a predetermined amount of time. Higher settings enable the cartridge air valve for a longer time, producing a larger dot.

Depending on the type of ink cartridge (A5, A6, or A8) and ink used (6990, 6993, 6997, 7824, 7824T, 8103, 8104), a 14 mil to 83 mil dot is possible. It is recommended that the proper dot size for the die be selected to maximize the cartridge usage and minimize problems with too large or too small dots.

DOT SIZE PARAMETERS								
DM-2.3 CARTRIDGE	INK TYPE 6990--6993--6997		INK TYPE 7824, 7824-T		INK TYPE 8103		INK TYPE 8104	
60 Inch Air Hose	Min	Max	Min	Max	Min	Max	Min	Max
A5	18 mil	30 mil	19 mil	33 mil	14 mil	25 mil	24 mil	46 mil
A6	20 mil	32 mil	24 mil	40 mil	19 mil	29 mil	36 mil	60 mil
A8	30 mil	51 mil	30 mil	60 mil	25 mil	39 mil	59 mil	83 mil
Microns	Min	Max	Min	Max	Min	Max	Min	Max
A5	457.2 μ m	762 μ m	482.6 μ m	838.2 μ m	355.6 μ m	635 μ m	609.6 μ m	1168.4 μ m
A6	508 μ m	812.8 μ m	609.6 μ m	1016 μ m	482.6 μ m	736.6 μ m	914.4 μ m	1524 μ m
A8	762 μ m	1295.4 μ m	762 μ m	1524 μ m	635 μ m	990.6 μ m	1498.6 μ m	2108.2 μ m

Note: Characterization testing performed at ambient temperature of 70 degrees F, relative humidity of 50% on polished, unetched silicon wafers (no passivation). Air pressure 70 PSI, at minimum and maximum controller settings. Dot size varies depending on passivation type and air pressure setting. See Section 7. System Specifications for a table in microns and mils.

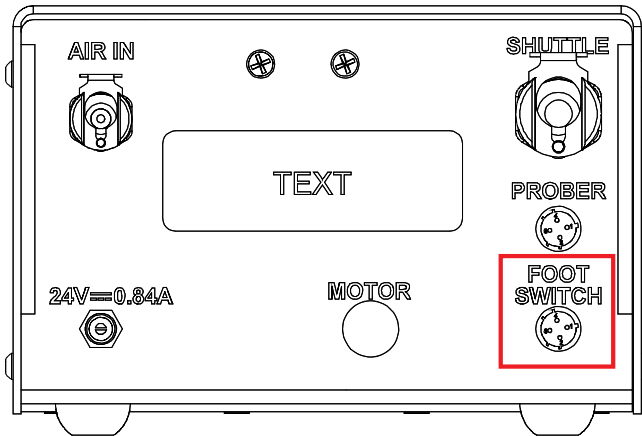

External Switch Input: There is a second input on the rear of the unit for use with a foot switch. Upon activation, the foot switch sends a > 50 mSec switch closure signal (across pins 1 & 3) to the controller, enabling an inking sequence. There is a 50-millisecond delay between the end of the sequence and the recognition of the next switch closure. No other adjustments or settings need to be made.

Ink Cartridge

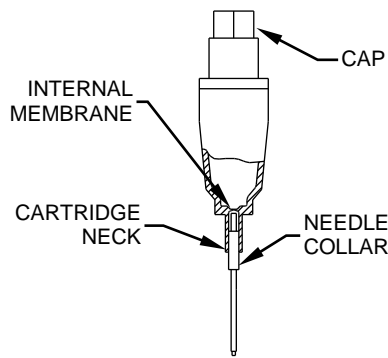

The ink cartridge used with the X5100 Series Inkers is a DM-2.3, available in A5, A6, and A8 (designating 0.005", 0.006", and 0.008" Teflon® tube I.D., respectively). DM-2.3 cartridges have a polypropylene reservoir (sealed at the bottom by a thin membrane) and a small Teflon® tube encased in a stainless steel needle. When the cartridge is opened, the needle punctures the membrane to provide ink flow through the Teflon® tube.

Each cartridge holds 1.0 grams minimum of ink and can produce a wide range of dot sizes. Dot size is controlled by changing the duration of the air pulse into the cartridge reservoir, which determines how much ink is forced through the Teflon® tube to create the ink drop at the needle tip. A5 and A6 cartridge types will produce an average of 30,000 dots*, while the A8 averages 10,000 dots*. For more information see **Section 5 "Ink"** and **"Ink Cartridge Specifications"** in **Section 7 "System Specifications."**

** Averages exclude 8104 ink type. Dot production figures are averages and as such, are not guaranteed. Testing is performed at ambient temperature of 70 degrees F, relative humidity of 50% on polished, unetched silicon wafers (no passivation) and based on pneumatic controller operating at "MIDDLE" dot size setting (standard controller = dot size knob centered between "MIN" and "MAX"; Motor-Z Controller = dot size thumbwheel setting of 50). Dot production figures represent an average of results for multiple ink types. Your yield may be higher or lower depending on the ink type and dot size setting you use. Average figures are based on complete cartridge use within **cartridge open shelf life periods** (5 days maximum or 3 days maximum) as stated for each specific ink type.*

Cartridge Preparation

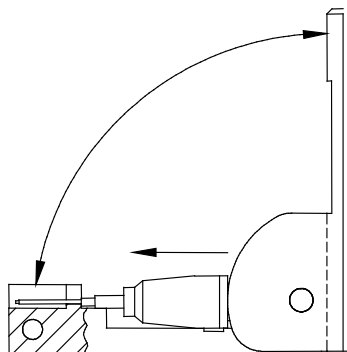

1. Place the cartridge into the cartridge preparation tool (Xandex Part No. 200-0001) as shown, exercising care to avoid damaging the Teflon® tip. The cartridge cap should be seated in the tool hinge with the needle resting in the slot.
2. Firmly squeeze the tool fully closed with a smooth, quick motion. This will push the cartridge body forward, causing the needle to puncture the internal membrane.
3. Open tool and remove cartridge. The needle should be straight and the needle collar flush with the cartridge neck.

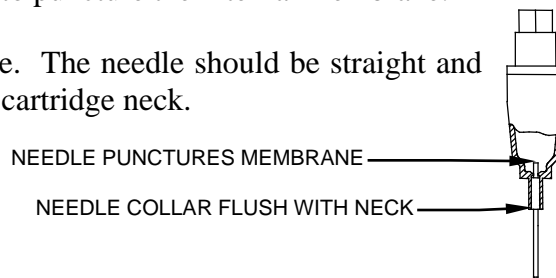

Cartridge Installation

Note: Do not shake the cartridge at any time, as air bubbles may be introduced into the reservoir and restrict the flow of ink. If mixing of the ink in the reservoir is desired, roll the cartridge between thumb and forefinger (or between palms) for 1-2 minutes prior to installation.

1. Use the slotted section of the cartridge preparation tool and a *counter-clockwise* motion to remove cap.
2. Lift the cartridge cap (attached to coiled red air hose) out of the inker. Thread the cartridge *clockwise* onto the cartridge cap until snug.

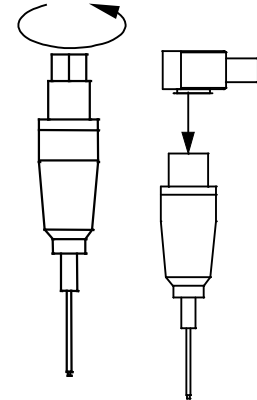

Cartridge Priming



Always wear protective eyeglasses when handling an active pneumatic inking system!

3. Hold the cartridge vertically (straight up and down; do not let ink run into the cartridge cap).
4. Prime cartridge by depressing and holding the RESET button to the right of the thumbwheels. After 3 seconds, the Controller will rapidly fire the Cartridge Valve (V1) to send pulses of air to prime the cartridge, sending ink to the Teflon® tip.

Note: When the "RESET" button is initially pushed the "INK ON" LED will not be lit and the "STATUS" LED will begin to flash. At the end of 3 seconds both the "INK ON" and "STATUS" LED will light continuously and the cartridge air valve will begin to pulse, priming the cartridge.

5. Once ink appears at the tip, release the RESET button and wipe the tip of the cartridge with a clean, lint-free cloth or swab.
6. Once priming is completed, snap the cartridge into the inker, engaging the dowel pin on the air fitting into the inker forks.

NOTICE

Use great care when inserting the cartridge into the inker body. The Teflon tube at the cartridge tip can be easily damaged by contact with the inker body.

Changing the cartridge

1. Move chuck/wafer from underneath the inker to prevent damage when removing or installing cartridge.
2. Place thumb and forefinger on each side of the air fitting and gently pull up to remove cartridge.
3. Unthread cartridge from the air fitting and discard in the proper manner.
4. Inspect the air fitting and air hose for ink contamination and clean or replace as necessary.
5. Install a new cartridge per installation instructions shown above.

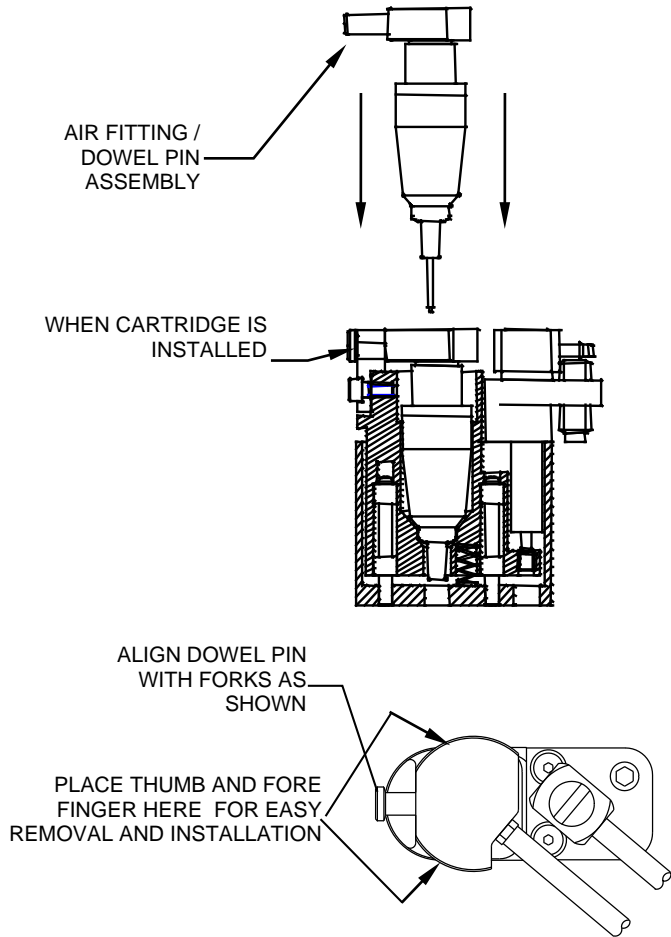

Note: Always use the *RESET* button to pulse the cartridge valve when priming a cartridge. The *RESET* button fires **only** the inker's cartridge valve.

Cartridge Priming and Use Tips**Tips to avoid common problems with DieMark Pneumatic Ink Cartridges.**

DO NOT attempt to refill Xandex DieMark Ink Cartridges. Cartridges are disposable and designed for single use only. Using a refilled cartridge will have an adverse effect on functionality and performance. Please note, Xandex does not warranty refilled cartridges.

Handling Tips:

Handle cartridges with care to avoid damaging the exposed Teflon tube at the tip of the needle

When removing the cartridges from the clamshell package, lift the cartridge straight up to avoid bending the needle or damaging the Teflon tube.

Allow the cartridge to reach optimal temperature of 18-25C (65-78F) before priming the cartridge. Never attempt to prime and use cartridges that are not at optimal temperature.

Priming Tips:

Wipe off any excess ink on the outside of the needle using a lint free cloth or swab before use.

DO NOT use the cartridges beyond the recommended open time for the ink type in the cartridge. Recommended open time is three (3) days for 7824, 7824T, 8103 and 8104, and (five) 5 days for 6990, 6993, and 6997.

Ink Cartridge Labeling

DieMark™ ink cartridges are individually labeled with two distinct labels. One label shows the cartridge type and the other label indicates the ink batch number, ink type and expiration date of the cartridge.

Do not remove the labels from the cartridges as this can cause cartridge type and ink types to be confused at cartridge installation, resulting in improper performance. Removal of cartridge labels will also void the cartridge warranty.

DieMark™ Cartridge Type Label

This label contains the cartridge type, (either **A5**, **A6** or **A8**).

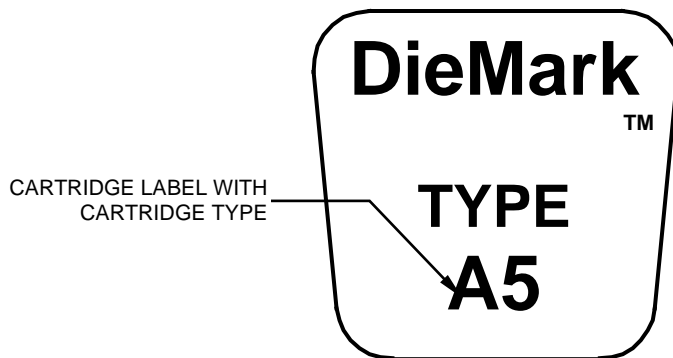

DieMark™ Cartridge Expiration Date Label



This label indicates the ink type and batch number of the ink contained in the cartridge and the cartridge expiration date. Expiration dates shown are for *unopened* cartridges.

- ◆ Markem® 6990, 6993, 6997 and Xandex 8103, 8104 = Four (4) months.
- ◆ Xandex 7824 and 7824T = Four (4) months.

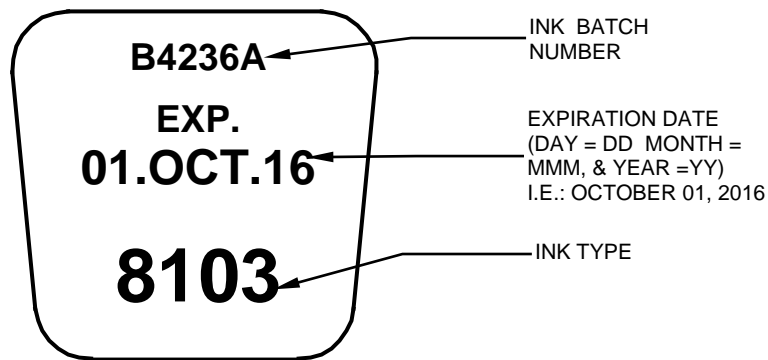
After the cartridge is opened, consistent ink flow can only be expected for up to five (5) days for Markem® 6990, 6993, 6997 and three (3) days for Xandex 7824, 7824T, 8103 and 8104.



Cartridge Type Label Color Coding

DM-2 & DM-2.3 PNEUMATIC CARTRIDGE LABELS	
LABEL	DESCRIPTION
	A5 IS RED
	A6 IS BLUE
	A8 IS YELLOW

Inker Assembly Setup & Alignment

1. Prepare, prime and install an ink cartridge per the instructions in this section (4).
2. Once priming is completed, snap the cartridge into the inker, engaging the dowel pin on the air fitting into the inker forks.
3. Set the prober stage "Z Up".

NOTICE	<i>If the inker height is adjusted with the prober stage "Z Down" the cartridge will be positioned too low and the cartridge needle will smash into the wafer when you begin inking. This will stop the ink flow and possibly ruin the cartridge or damage the wafer!</i>
---------------	---

4. Set the controller "DOT SIZE" adjustment knob to the middle of the adjustment range. Move the locking toggle switch to "SETUP". The "INK ON" LED will flash continuously and the shuttle will extend to its lowest position. Create a droplet of ink at the needle tip by pressing the prober "TEST INKER" button twice.

Note: The Controller can remain in the "SETUP" mode for a maximum of 5 minutes. After 5 minutes, the Controller will disable the shuttle air valve, returning the shuttle to normal position (the inker will fire, but the shuttle will not move). If this happens, move the toggle switch to "RUN" then back to "SETUP" to complete alignment.

5. Slowly turn the Z Adjust screw counterclockwise to lower the inker until the ink droplet at the needle tip touches the wafer surface. The Teflon® tube will be 1-2 mil from the wafer surface.
6. Lock the inker in place using the set screw in the optical channel. Set the toggle switch to "RUN" to retract the shuttle. Index and test fire the inker a few times and check the dots for size and roundness. Each time the inker fires, the "INK ON" LED flashes.
7. After initial set-up is completed, some additional adjustment of the Z height may be required to achieve round dots. It is recommended to step the chuck up or down as required, as this provides more precise adjustment than trying to move the inker. Adjust the dot size knob until the desired size is achieved. If you have problems, refer to **Section 6 “Maintenance & Troubleshooting.”**

NOTICE

Do not let the Teflon® cartridge tube contact the wafer surface. This may crush the tip preventing ink flow and damaging the cartridge or the wafer!

Section 5. Ink

General Information

Semiconductor manufacturers use the vision system of automatic pick and place equipment during the assembly process to detect damaged and/or rejected die. This is done by shining a combination of different lights on the wafer surface to create a “white” background. Ink dots and defects such as chipped corners are easily recognizable against this background.

Xandex 8103, 8104, 7824, 7824T and Markem[®] 6993 inks are opaque and easily recognizable under all lighting conditions. Xandex Glycol Free 8103 ink is thick in viscosity and delivers opaque dots ranging from 6 to 40 mils. Xandex 8104 is not as viscous as 8103 and provides thinner dots with excellent geometry and adhesion in a larger dot range up to 86 mils. Markem[®] 6990 and 6997 are less opaque and may not offer sufficient contrast under all lighting conditions.

Xandex 8103 ink is certified to contain less than 10 ppm of Sodium (Na) and Chloride (Cl). Xandex 8104 ink is certified to contain less than 20 ppm of Sodium (Na) and Chloride (Cl). Both 8103 and 8104 premium inks are free of glycol ethers, which are identified reproductive hazards and carcinogens. Xandex 7824 and 7824T inks are certified by Xandex to contain less than 10 ppm of Na and Cl. Markem[®] 6990 is certified by Markem[®] to contain less than 25 ppm of Na and Cl. Analysis reports are available upon request from Xandex Customer Service.

Although Markem[®] 6993 and 6997 are not contaminant controlled, periodic test data indicates that these inks typically contain less than 100 ppm of Sodium (Na) and 400 ppm of Chloride (Cl). These levels are not certified or guaranteed by Markem or by Xandex¹.

Xandex Glycol Free 8103 and 8104 inks have a 4 month shelf life, rapidly air dry at ambient conditions and will give consistent flow for 3 days after cartridge opening. Markem[®] 6990, 6993 and 6997 inks have a 4 month shelf life, require heat curing to be permanent, and will give consistent flow for 5 days after cartridge opening. Xandex 7824 and Xandex 7824T inks have a 4 month shelf life and will give consistent flow for 3 days after cartridge opening. Xandex 7824 and 7824T can be air or “heat set” cured.

Xandex Glycol Free 8103 and 8104 inks are thermally stable at temperatures up to 150° C and can be used in hot chuck or oven drying applications without cracking or loss of adhesion. Use of either Markem[®] 6990, 6993 and 6997 or Xandex 7824 and 7824T inks in hot chuck applications is not recommended as the elevated ambient temperature in the probing area can reduce cartridge life and cause inconsistent ink flow. However, use of a hot chuck to heat set dots during offline inking has reportedly been successful when employed by some customers. All of the inks offered by Xandex are non-magnetic.

Safety Data Sheets (SDS) are available for all inks offered by Xandex. To obtain SDS or information about choosing the appropriate ink for your application please contact your local distributor or Xandex Customer Service. ¹ Test results are dependant on test method

Ink Curing

The procedure for curing will depend on the type of ink used. Markem® 6990, 6993, and 6997 should be cured/baked within 2 hours of inking due to the evaporation of solvents in the ink over time. If a wafer (or boat of wafers) is left uncured for an extended period of time, the dots may crack and/or flake after the baking process.

Markem® 6990, 6993, and 6997 inks, which are air-dried, will not smear when touched. They are not permanent, however, and will not withstand most post-probe handling or processes. Conversely, Xandex 7824 and 7824T inks air cure within 2.5 hours (≤ 20 mil, up to 8 hours for >20 mil dots). Xandex 7824 and 7824T may also be “heat set” at 120°C for 10 minutes.

Xandex 8103 and 8104 Glycol Free inks hard cure under ambient conditions in the least time of any of the inks offered by Xandex. Ink dots of ≤ 25 mil air dry to a hard cure in 45 minutes. Dot sizes >25 mil may require significantly longer to cure. An ambient cure time of up to 6 hours may be needed for larger dot sizes. Continuous air flow across the wafer surface will reduce the amount of time required for curing. The following table provides specifics for each type of ink:

INK CURING			
CURE TYPE	TEMPERATURE	CURE TIME	RESULT
Markem® 6990, 6993, and 6997			
Soft Cure	100-150°C	5-15 minutes	Ink is semi-permanent and will not withstand wash of alcohol, acetone, or photoresist removers
Hard Cure	150-185°C	30-60 minutes	Ink is permanent and resistant to wash process
Xandex 7824, 7824T			
Hard Cure	Air dry, ambient conditions	2.5 hours \pm 0.25 hrs for ≤ 20 mil, up to 8 hrs >20 mil.	Ink is permanent and may only be removed with great difficulty
Hard Cure	150 watt heat lamp at 5-6 inches OR oven at 110-120°C	5-10 minutes	Ink is permanent and may only be removed with great difficulty
Xandex 8103 and 8104 Glycol Free			
Hard Cure	Air dry, ambient conditions	5-15 minutes for 5-15 mil 15-45 minutes for 15-25 mil 45 min-6 hours for 25-40 mil	Ink is permanent and may only be removed with great difficulty

Note: Longer drying times are required for larger dot sizes.

Note: Markem® is a registered trademark of Markem Corporation, Keene, NH

Ink Removal Information

A rinse with isopropyl alcohol or acetone generally removes ink completely if the wafer is washed shortly after inking (within 5 minutes). An ultrasonic bath is recommended to ensure complete removal of ink residue. Ink dots, which have been air dried or hard cured, require the application of an ink remover.

DieMark Remover 8000

Xandex has developed DieMark Remover 8000 specifically for the semi-conductor industry. DieMark Remover 8000 thoroughly removes all inks supplied by Xandex, including oven baked ink dots. DieMark Remover 8000 has very low levels of organic and inorganic contaminants and is an efficient and thorough ink remover when used in simple bench top cleaning methods. Due to its high flash point, DieMark Remover 8000 is also safe and effective when used in ultrasonic, temperature/pressure cycling under vacuum and deep bath heating and agitation ink removal processes.

DieMark Remover 8000 is carcinogen free (NTP, OSHA) and all ingredients used are TSCA listed. For an MSDS or more information on using DieMark Remover 8000 in your specific ink removal process, contact Xandex Customer Service.

Ink Removal Procedure

The following is the recommended bench top procedure for removing ink from wafers using DieMark Remover 8000. *



All procedures should be performed under a laboratory hood, following proper safety precautions (protective goggles, gloves and clothing).

1. Apply sparingly with an eyedropper to a localized area of the wafer.
2. Allow 2-3 minutes for the DieMark Remover 8000 to begin solvating. Time required will vary depending on the degree that the ink was cured.
3. For highly cured ink dots, use longer soak times, then wipe gently with a clean lint-free cloth to facilitate removal. If necessary, repeat steps 1 and 2.
4. For large areas or removal of ink from entire wafer, soak a clean lint-free cloth with DieMark Remover 8000, then lay the wet cloth over the entire surface and allow time to soak/solvate ink, then remove wet cloth. Repeat as necessary.
5. After dots are removed, clean wafer via standard procedures, such as vapor degreasing, and/or rinse with a clean solvent (Isopropyl Alcohol) followed by a bake cycle at 65° C to dry.

* The following ink removers may be substituted for DieMark Remover 8000, however, Xandex does not guarantee that satisfactory results will be obtained. None of the following solvents or ink removers are available from Xandex.

- ◆ Aptek 6515 Ink Remover
- ◆ Markem® 540
- ◆ P-300 Resist Remover
- ◆ 712-D Resist Remover
- ◆ Uresolve Resist Remover
- ◆ Methyl Ethyl Ketone (MEK)
- ◆ N-Methyl-2-Pyrrolidone (M-Pyrrol)

Section 6. Maintenance & Troubleshooting

This Troubleshooting section for the X5100 Pneumatic Inker is divided into three parts. The first part covers ink and the ink cartridge. The second part covers the Inker Assembly, and the third part covers the Pneumatic Controller. See the Support section at <http://www.xandexsemi.com/> for more troubleshooting information.

Ink Troubleshooting

Problem	Solution
Some ink dots tend to crack after baking using Xandex recommended cure cycles.	This occurrence is related to the ink surface tension, the wafer surface conditions and too long a delay time between inking and curing. To remedy this situation, the curing cycle has to be modified (reduce time and temperature). See Section 5 “Ink Curing.”
Runny, blobbing ink or skipping dots.	<ol style="list-style-type: none"> 1. Check ink shelf life. Markem® 6990, 6993, 6997 inks should be used within 4 months or 5 days of cartridge opening. Xandex 8103 and 8104 air dry glycol free inks should be used within 4 months or 3 days of cartridge opening. Xandex 7824 and Xandex 7824T air-dry ink within 4 months or 3 days after cartridge opening. 2. Check for exposure to extreme temperatures. Cartridges should be stored at 25°C. DO NOT refrigerate the cartridges. Occasionally, ink is subjected to much higher temperatures (40-50° C) for an extended time during transport. This could break down the ink such that its viscosity and surface tension are altered permanently. Contact Xandex Customer Service. 3. Improper Z Height set-up. Review proper procedures detailed in Section 4 “Cartridge Setup and Alignment” and re-adjust Z Height. 4. Chuck top or wafer surface not planar. Verify planarity of both.
After changing the controller dot size settings, the dots are too small or the ink blobs at the tip of the needle.	<ol style="list-style-type: none"> 1. The cartridge tip may be damaged. Examine cartridge and replace if necessary. 2. Whenever dot size is changed there may be minor Z height adjustments required. The inker should be set so that just the bottom of the ink drop touches the wafer.

Problem	Solution
<p>Small, inconsistent or no ink dots.</p>	<ol style="list-style-type: none"> 1. Soft Teflon® tip of the cartridge tube is clogged or damaged. Change cartridge. 2. The dot size setting may be too low. Increase dot size setting. 3. Wrong cartridge type. Change cartridge type. 4. Air pressure too low, verify setting is 70 ± 10 PSI. 5. Z height adjustment is incorrect. Adjust Z Height. See Section 4 “System Operation.” 6. Verify that the inker is locked in position with the set screw and roll pin. 7. Shuttle mechanism may be binding. See “Shuttle Maintenance” in this section.

Inker Troubleshooting

Problem	Solution
Dots too large.	<ol style="list-style-type: none"> 1. Dot size setting too high. Decrease dot size setting. 2. Main Air pressure too high, verify setting at 70 ± 10 PSI. 3. Wrong cartridge type. Change cartridge type. 4. Dot size potentiometer defective. Run diagnostic test B. described in "Controller Diagnostics" later in this section (6). If test results are not within parameters, consult Xandex Customer Service.
Cartridge tip does not reach wafer surface.	<ol style="list-style-type: none"> 1. Check Z height by switching the controller into "SETUP" mode, which will extend the shuttle downward into the "inking position". 2. Adjust Z height per "Setup and Alignment" in Section 4 "System Operation" of this manual.
Unit functions normally, no dots, no shuttle movement.	<ol style="list-style-type: none"> 1. Verify that the Controller-shuttle air hose connector is plugged into the controller. 2. Verify that the Controller-shuttle air hose is not kinked, clogged or pinched closed. 3. Check Main Air pressure setting (verify 70 ± 10 PSI air input).
Inker produces dots during "puff pulse" or ink flows out of cartridge with toggle switch in "SETUP".	<ol style="list-style-type: none"> 1. Verify that the air hoses from the controller to the inker are connected properly: <ul style="list-style-type: none"> ◆ RED AIR HOSE connects to the ink cartridge. ◆ BLUE AIR HOSE connects to the shuttle connection on the shuttle mechanism.

Problem	Solution
Unit functions normally, shuttle moves, no dots.	<ol style="list-style-type: none"><li data-bbox="657 262 1360 336">1. Check air hose to top of cartridge to be sure it is connected and not kinked, clogged or pinched.<li data-bbox="657 367 1360 525">2. Verify cartridge preparation, insuring Needle Collar is flush with the Cartridge Neck and the internal membrane is broken. See Section 4 “Ink Cartridge.”<li data-bbox="657 556 1360 630">3. Check the Teflon® tip of cartridge tube to confirm that it is not clogged or damaged.<li data-bbox="657 661 1360 735">4. Verify that the rubber washer on the cartridge air hose connector is installed.

Shuttle Maintenance

Schedule and Preventive Maintenance Kits

Periodic preventive maintenance of the shuttle mechanism is recommended to ensure continued, trouble free operation of your Xandex pneumatic inking system. The recommended maintenance schedule is as follows;

- Off-line use = 6 month intervals
- In-Line / Post Probe use = Once per year

Shuttle preventive maintenance kits are available, which include all parts necessary for one normal shuttle maintenance procedure. These kits may be ordered direct from Xandex or through your local Xandex distributor. The X5100 model inker requires kit number 370-0004.

The following describes the procedure for performing disassembly, inspection, and re-assembly of the X5100 Inker Assembly for maintenance purposes. It will be necessary to have a 0.050" Allen wrench and a 0.049" Gauge Pin. Reference drawing 320-5100 in on the Drawings CD included with this manual for part identification and associated part numbers.

Inker Maintenance

1. Remove the ink cartridge (if installed). Remove the inker from the prober. Retain all inker mounting screws.
2. Remove the *cartridge fitting assembly* (Item 9) from the *inker assembly*. Inspect the *cartridge fitting assembly* (Item 9) for ink contamination or damage. Clean *cartridge fitting assembly* (Item 9) as necessary and replace the washer (Item 15).
3. Disconnect the *twin pneumatic hose* (Item 18) from the shuttle at the *elbow fitting* (Item 7) connection (grasp, do not crush, the hose with needle nose pliers over the fitting point and pull gently to disconnect, being careful not to damage hose). 60" of extra hose is included in the kit (Item 18). If the *twin pneumatic hose* (Item 18) has been damaged, measure the old hose and replace it with the same length of new *twin pneumatic hose* (Item 18).

Inker Disassembly

With the Inker removed from the Prober and the ink cartridge removed: (See Section 4 "Ink Cartridge.")

1. Remove the two 2-56 X 1/2 SS *screws* (Item 12) from the *solenoid bracket* (Item 2), then remove the *solenoid bracket / cylinder assembly* (Items 7, 2 and 6).
2. While holding the *shuttle* (Item 1) in the *housing assembly* (Item 8), turn the *housing assembly* (Item 8) upside-down.

3. Carefully lift the *housing assembly* (Item 8) off of the *shuttle* (Item 1), paying attention to the two *compression springs* (Item 16) located in the *shuttle* (Item 1).
4. With the *housing assembly* (Item 8) removed, remove the two *compression springs* (Item 16) and place in a safe location.

Part Inspection and Cleaning

With the Shuttle removed and disassembled, perform the following checks to verify condition/operation.

1. Clean the *shuttle* (Item 1) and *housing assembly* (Item 8) with Isopropyl Alcohol and a clean lint free cloth. Inspect the *shuttle* (Item 1) and *housing assembly* (Item 8) for obvious signs of wear or rubbing. Replace as necessary
 2. Inspect the *pneumatic cylinder* (Item 6), mounted on the *solenoid bracket* (Item 2) by manually pulling on the cylinder shaft and verify smooth operation.
 3. Connect an air line to the *elbow fitting* (Item 7) on the *solenoid bracket* (Item 2) and apply/remove an 80 PSI air signal. Check for leaking *elbow fitting* (Item 7) or *cylinder* (Item 6) and verify the operation of the *cylinder* (Item 6) under pressure.
 4. Inspect the *cartridge fitting assembly* (Item 9) for ink contamination or damage. Clean the *cartridge fitting assembly* (Item 9) as necessary and replace the *washer* (Item 15). The RED side of the *twin pneumatic hose* (Item 18) connects to the *cartridge fitting assembly* (Item 9).
 5. Inspect the *compression springs* (Item 16) for fatigue or physical deformation. Free length of the *spring* is $0.250'' \pm 0.005''$ nominal. The two *compression springs* (Item 16) should differ from each other in length by no more than $0.016''$. Replace as needed.
 6. Remove the nylon tipped *set screw* (Item 13) from the bottom of the *shuttle* (Item 1).

Re-Assembly

1. Holding the *shuttle* (Item 1) upside-down, install the two *springs* (Item 16) in the appropriate holes and slide the *housing assembly* (Item 8) over the *shuttle* (Item 1).
2. Turn the assembly right side up and install the solenoid bracket / cylinder assembly (Items 2 and 6). using the two screws (Item 12) removed during disassembly and tighten to 3-5 in-lbs.

3. Apply a dab of Loctite 222 to the threads of the new set screw (Item 13) from the kit and install through the hole in the bottom of the housing assembly (Item 8). Take care that there is no excess Loctite on the nylon tip of the set screw (Item 13). Check the shuttle actuation adjustment by placing a 0.049" gauge pin in the side hole in the housing assembly (Item 8). Adjust the set screw (Item 13) through the hole in the base of the housing assembly (Item 8) until the shuttle (Item 1) lightly contacts the gauge pin.
4. Connect the BLUE side of the twin pneumatic hose (Item 18) to the elbow fitting (Item 7) on the solenoid bracket (Item 2) and apply/remove an 80 PSI air signal a few times, verifying smooth actuation of the shuttle.
5. Re-install the inker on the prober and place test dots to verify inker operation.

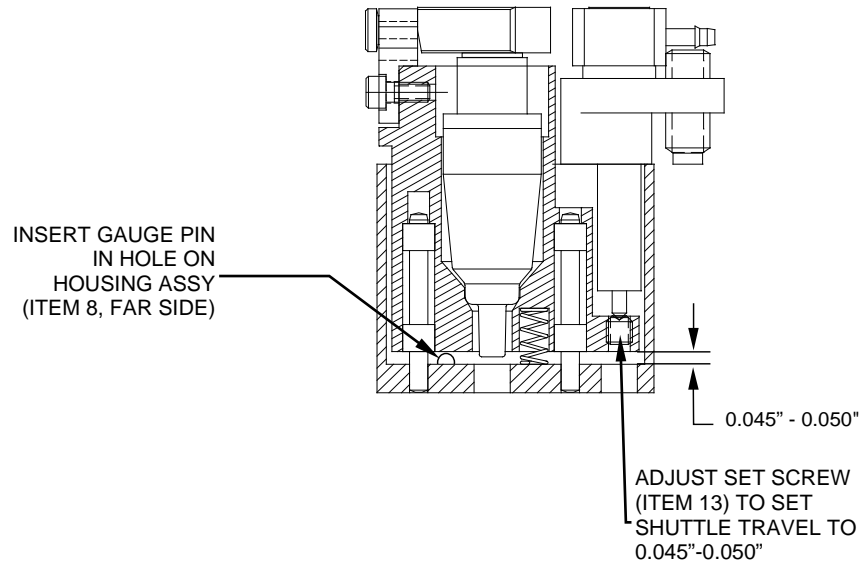

Pneumatic Controller**Controller Sequence of Operation**

To initiate an ink dot, the Prober sends a 22-60 V (AC/DC unregulated) active-high signal to the Controller. After receipt of the signal, the microcontroller performs various checks of system status prior to firing the pneumatic valves.

Upon completion of the status checks, a 23.3ms pulse is sent to the *Shuttle Valve*, while at the same time a 7.15-25.65ms pulse (depending on position of Dot Size knob) is sent to the Cartridge Valve (V1).

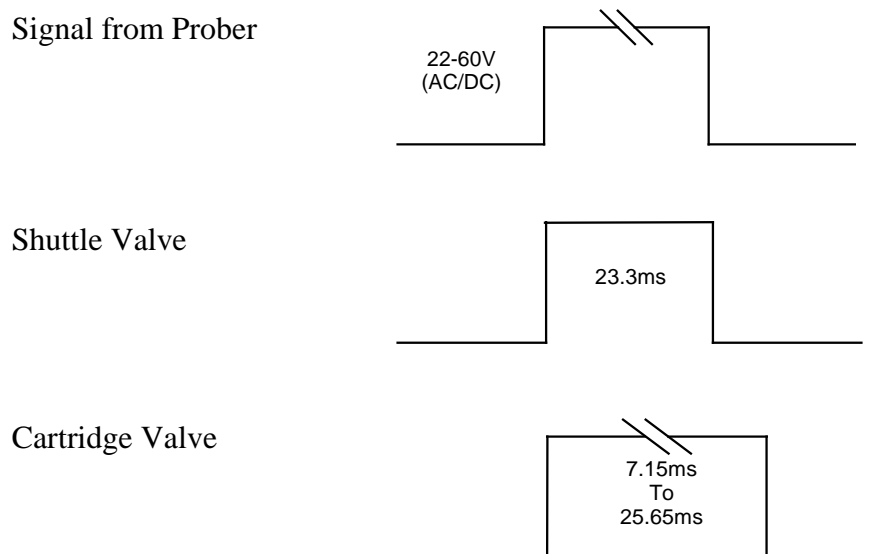

As the shuttle extends to the lower position, the air pulse from Valve 1 forces ink out of the cartridge barrel and forms a drop at the end of the needle tip. When the shuttle is at its lowest position, the drop makes contact with the wafer surface and forms a dot. The shuttle then returns to the normal position.

At the completion of each dot, a small amount of vacuum is developed in the cartridge by the closure of the valve, preventing dripping. If another dot sequence is not initiated within 10 seconds, a short "puff" pulse equal to 1/2 the dot size duration (6.75 - 13.15ms) is sent to the cartridge to displace a small amount of ink back into the Teflon® tube to aid in maintaining proper dot size after a long delay between dots.

Controller Diagnostics

There are a few internal diagnostic tests available for testing the Controller. To enter the Diagnostics mode, apply power to the Controller with the “RESET” button to the right of the thumbwheels depressed.

The following tests are available:

A. Test Thumbwheels

1. Place the toggle switch on the front panel to SET-UP, set the thumbwheels to 12345, then reset the LCD Counter.
2. Press the RESET button and verify that the counter increments 15 counts.
3. Place the toggle switch to RUN, set the thumbwheels to all 1's, reset the LCD Counter, and press RESET. The counter should increment one count.
4. Repeat the procedure for the rest of the digits (2 through 9). With the thumbwheels set for 00000, the counter increments 10 counts.

B. Test Dot Size Potentiometer

1. Place the toggle switch to DISABLE, set the HOURS thumbwheels to 01, then reset the LCD Counter.
2. With the Dot Size knob set at the minimum position, press the RESET button and verify that the LCD Counter does not increment.
3. Set the knob to 50% and press RESET. The Counter should display approximately 130 counts. (Variations in Dot Size knob alignment to scale may occur. An increment of ± 10 is not significant in this case.)
4. Reset the LCD Counter, adjust the knob to maximum, and press RESET. The Counter should display 255 counts.

C. Test Cartridge Valve

To test fire the Cartridge Valve 20 times:

1. Set the HOURS thumbwheels to 02
2. Place the toggle switch to DISABLE
3. Reset the LCD Counter
4. Press RESET.

The cartridge valve fires 20 times, each time incrementing the LCD Counter.

D. Test Shuttle Valve

To test fire the Shuttle Valve 20 times:

1. Set the HOURS thumbwheels to 03
2. Place the toggle switch to DISABLE
3. Reset the LCD Counter
4. Press RESET.

The shuttle valve fires 20 times, each time incrementing the LCD Counter.

E. Life Test

This test will continuously fire the Cartridge and Shuttle valves for a predetermined number of cycles as set on the thumbwheels.

1. Place the toggle switch to DISABLE.
2. Set the HOURS thumbwheels to 10.
3. Set the DOTS X1000 thumbwheels for the desired number of cycles X1000 (i.e.: 250 Equals 250,000 cycles).
4. Reset the LCD Counter.
5. Press RESET.

The Controller begins continuous firing, incrementing the Counter each cycle. To discontinue the Life Test prior to reaching the set amount, remove power.

Controller Troubleshooting

Problem	Solution
The Unit is plugged in but the "POWER" LED is off.	<ol style="list-style-type: none"> 1. Make sure that the AC outlet has power. The requirement is 100-240 VAC @ 47-63Hz. 2. Verify that the power supply is connected to the 24V input on the back of the controller and that the ON/OFF switch on the controller is in the ON position.
Unit powers up okay but will not respond to prober signal.	<ol style="list-style-type: none"> 1. Verify input cable is plugged into the prober input on the Controller. 2. Verify input cable is plugged into inker jack on prober. 3. Check continuity of input cable. 4. Perform system diagnostics checks to verify Controller operation. See Section 6 "Controller Diagnostics."
Unit powers up okay, responds to prober input but the shuttle does not move.	<ol style="list-style-type: none"> 1. Check that shuttle toggle switch on the front of the controller is in the RUN position. 2. Check that the air hose "quick disconnects" are correctly oriented. 3. Perform Shuttle Valve diagnostic test to verify operation. See Section 6 "Controller Diagnostics."
Dot size does not change or does not change sufficiently with adjustment of Dot Size Knob	<ol style="list-style-type: none"> 1. Verify that the air hoses from the controller to the inker are connected properly: <ul style="list-style-type: none"> • RED AIR HOSE connects to the ink cartridge. • BLUE AIR HOSE connects to the shuttle connection on the shuttle mechanism.

Problem	Solution
Dot size does not change or does not change sufficiently with adjustment of Dot Size Knob (continued)	<ol style="list-style-type: none"><li data-bbox="722 262 1347 451">2. Run diagnostic test “B.” Dot Size Potentiometer Test described in “Controller Diagnostics” above in this section (6). If test results are not within parameters, consult Xandex Customer Service.<li data-bbox="722 483 1347 630">3. Wrong ink cartridge type. Replace ink cartridge with larger (or smaller) type dot size rating. See “Dot Size Parameters” table in Section 4. “Operation.”

Internal Maintenance**NOTICE**

Use appropriate ESD precautions when working inside of the controller!

! WARNING

Making any modifications to the controller circuitry or components other than Xandex recommended maintenance procedures may void your controller warranty, disable protections provided by the manufacturer and expose the user to electric shock hazard.

Turn Audible Alarm ON/OFF

Standard controller units (P/N 350-0002) with serial numbers higher than 4000 are equipped with an audible alarm feature. When enabled, an audio alarm will sound (in addition to the STATUS LED illuminating) when the programmed number of dots set point is reached. The controller is shipped with the audio alarm feature disabled.

With Power and Main Air removed:

1. Remove the cover by removing the 8 screws on the left and right sides of the controller (4 screws per side) and lifting the cover off the controller assembly.
2. Locate J16 on the 250-1226 controller printed circuit board. In the default factory condition, J16 is populated with a jumper on pins 1 and 2. This is the default audio alarm disabled condition.
3. To enable the audio alarm remove the jumper and install the jumper onto pin 1 only on J16. This is the audio enabled condition.

Before Returning the Controller to Service

1. Install the cover, apply power and main air, and perform controller diagnostics, as documented in this chapter, to verify operation. If problems are noted, review the installation of the audio alarm jumper to ensure installation is correct, none of the component leads are bent, and verify connection of J2 through J6 connectors on the printed circuit board.

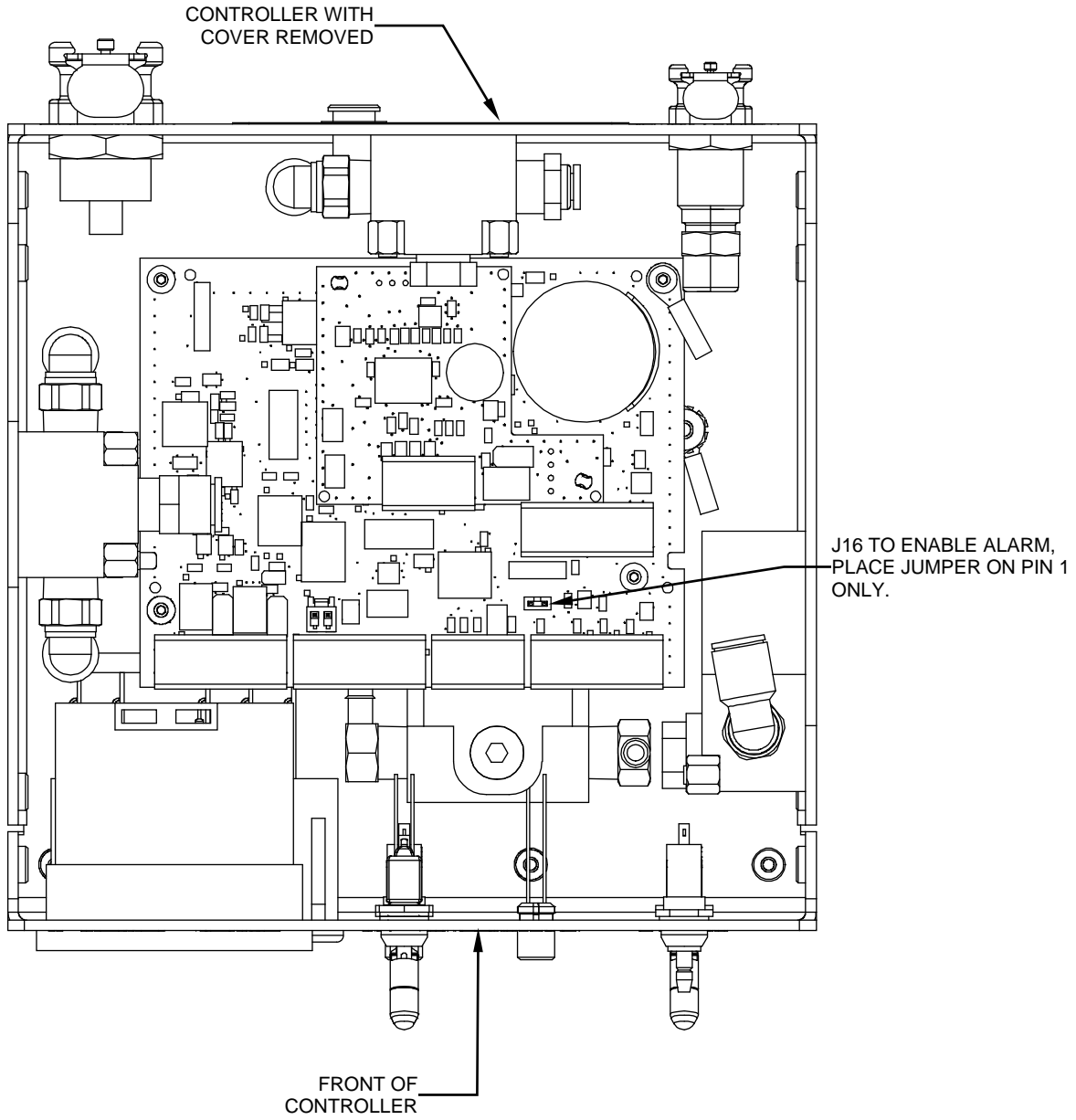

Preventive Maintenance

Pneumatic Controller Preventive Maintenance Schedule and Sets

There are two solenoid driven air valves used in Xandex pneumatic controllers to drive the Pneumatic Shuttle and Ink Cartridge. Valve one (V1) supplies air to the ink cartridge, and is referred to as the Cartridge Valve. Valve two (V2) supplies air to the pneumatic shuttle and is referred to as the Shuttle Valve.

Xandex Motorized Z controllers contain a third valve (V3) that is identical to the Shuttle and Cartridge valves. The Motorized Z uses this valve to change the air pressure supplied to the cartridge valve when inking in small dot mode. In normal operation, the third valve (V3) in the Motorized Z controller will not need replacement for the life of the unit.

Preventive maintenance for Xandex pneumatic controllers requires replacement of just the Cartridge Valve, or of both the Cartridge and Shuttle valves at the intervals specified below.

Controller Model	Replace	Interval
All Models	Cartridge Valve	Continuous High Speed Use = 6 months All other applications = 12 months
All Models	Cartridge Valve, Shuttle Valve and internal tubing, as required	Every 24 months

Two valve replacement sets are available from Xandex to facilitate controller preventive maintenance.

- Cartridge Valve Set, containing a single cartridge valve assembly, pneumatic and electrical connectors and replacement instructions. This set is used for 6/12 month cycle controller preventive maintenance that replaces the cartridge valve. Order part number 370-0105.
- Dual Valve Set containing one cartridge valve assembly and one shuttle valve assembly, pneumatic and electrical connectors, adequate tubing to replace all internal controller pneumatic routes in all Xandex pneumatic controllers and replacement instructions. This set is used for 24 month controller preventive maintenance that replaces both the cartridge valve and the shuttle valve. Order part number 370-0106.

**The kits listed here are compatible with Xandex pneumatic controllers with serial numbers over 4000 that use an external AC/DC power transformer (brick). If your controller plugs directly into the wall socket without an external power transformer, order Cartridge Valve Set 370-0100 and Dual Valve Set 370-0101.*

For more information or to order pneumatic controller PM sets, contact Xandex Customer Service at (707) 763-7799, (800) 767-9543 (toll free in the US), FAX (707) 763-2631; email <mailto:info@xandex.com> or order online at <http://www.xandexsemi.com/>.

Valve Replacement**Cartridge (V1) or Shuttle (V2) Valve Replacement**

Note: This generic procedure can be used for replacement of either the Cartridge or Shuttle valves.

NOTICE

The Cartridge Valve and the Shuttle Valve have the same form factor but are NOT INTERCHANGEABLE. The Cartridge Valve is a 12VDC valve and the Shuttle Valve is a 24VDC valve. Failure to install the correct valve at either location will result in a non-operational controller.

With Power and Main Air removed:



1. Remove the four (4) cover screws from each side of the controller and remove the controller cover.
2. Disconnect the input and output pneumatic hoses from the defective valve by depressing the colored fitting collar and pulling on the pneumatic hose simultaneously.
3. Disconnect the two snap in connectors that connect the valve wires to the controller.
4. Remove the two Phillips mounting screws securing the valve to the Controller base and remove the valve.

Installation:

1. Match fittings from the kit to the ones installed on the old valve and install them on new valve assembly using Teflon thread sealant tape (not supplied).
2. Install the replacement valve assembly in the *controller base*, securing with the two Phillips screws previously removed.
3. Connect the two snap in connectors on the valve wires to the receptacle connectors on the controller. Polarity does not matter.
4. Install the pneumatic lines accordingly, insuring that each hose is firmly seated in the valve fitting.
5. Apply power and main air.
6. Refer to “Controller Diagnostics” in this section and perform appropriate valve functional and diagnostic tests. Re-install the controller cover.

Section 7. System Specifications

DC Power Supply Requirements

Input Power Requirement:	100-240 VAC @ 50-60Hz
Output Power Requirement:	24V  (VDC) / 0.8A or greater
Approvals:	UL / FCC / PSE / CCC / CE / WEEE / ROHS
Protection:	Overvoltage/Short Circuit
Output Pin Assignments:	Center: +V Outside: Return 
Output Plug Size:	Outside Diameter: 5.5mm Inside Diameter: 2.5mm Barrel Length: 9.5mm

The DC power supply received with your DieMark inking system meets these requirements. Use only the DC power supply provided with the unit or an authorized replacement power supply from Xandex Inc. or an approved Xandex distributor. For the exact specification of your power supply, see the “24VDC Power Supply” drawing included in your product manual drawing package.

Pneumatic Controller Specifications

Size:	6" x 6" x 4" (152mm x 152mm x 102mm)
Weight:	2.5 lbs (1.13 kg)
Input Power Requirement:	24V  (VDC) 0.84A
Foot Switch Input:	Contact Closure >50 msec
Air Consumption:	70 PSI ±10 PSI Instrument Air per ISA 7.3 specification <0.5 cfm @ 10 dots/second
Cycle Rate:	Exceeds 750 cycles/minute
On-Time Range:	Cartridge Air Feed - Continuously Variable Pulse (7.15-25.65 msec) Shuttle Air Feed - Fixed @ 25.2 msec
Counters:	Six Digit with External Reset (Independent of Microprocessor)
External Regulator/Filter:	5.0 micron Air Filtration

Prober Input:

22 - 60 volts @ minimum 30 ms pulse width. The input circuit presents approximately 1 K Ω - 700 Ω input resistance. Typical current as a function of input voltage is listed in the following table:

15 V	25 mA
20 V	45 mA
40 V	65 mA
60 V	85 mA (Maximum input)

Environmental Range:

- Indoor use
- Altitude up to 2,000 m
- Temperature range 5° C to 40° C
- Maximum relative humidity 80 % for temperatures up to 31°C decreasing linearly to 50 % relative humidity at 40 °C

Certifications:



Standards to which conformity is declared:
 EN61010-1 / EN61326-1
 Marked for LVD and EMC

RoHS

RoHS Compliant with EU Directive 2011/65/EU



This device complies with FCC Rules Part 15. Operation is subject to the following two conditions:
 (1) This device may not cause harmful interference, and
 (2) This device must accept any interference that may be received or that may cause undesired operation.



Xandex Inc. has labeled its branded electronic products with the WEEE Symbol to alert our customers that products bearing this label should not be disposed of in a landfill or with municipal or household waste in the EU.

Ink Cartridge Specifications

Models:	DM-2.3, Type A5, A6, A8
Teflon Tube I.D.:	A5 - 0.005" / A6 - 0.006" / A8 - 0.008"
Reservoir Capacity:	1.0 grams minimum
Available Inks:	6990, 6993, 6997, 7824, 7824T, 8103, 8104
Dot Sizes:	Dot sizes ($\pm 10\%$) consistent for speeds of 12 dots/second to 1 dot/2 minutes

Cartridge Availability

The following table illustrates ink and cartridge configurations. Configurations designated with a 0 are available as a Customer Specific Product (CSP) but have not been tested by Xandex and are subject to limited warranty conditions. The information in this table is accurate as of the time of publication but is subject to change without notice.

Ink Type	Pneumatic Cartridge Types						Filament Cartridge Types						DM-1.25			DM-S	
	DM-2			DM-2.3			DM-1						10 mil	15 mil	25 mil	10 mil	15 mil
Markem Inks	A5	A6	A8	A5	A6	A8	5 mil	8 mil	10 mil	15 mil	25 mil	30 mil	10 mil	15 mil	25 mil	10 mil	15 mil
6990 Black	+	+	+	+	+	+	T,F	+	+	+	+	+	+	+	+	+	+
6993 Black	+	+	+	+	+	+	+	+	+	+	+	+	+	+	+	+	+
6993 Red	+	+	+	+	+	+	T,F	+	+	+	+	+	+	+	+	+	+
6997 Black	+	+	+	+	+	+	T,F	+	+	+	+	+	+	+	+	+	+
Empty (no ink)	+	+	+	+	+	+	+	+	+	+	+	+	+	+	+	+	+
Xandex Inks																	
7824 Black	+	+	+	+	+	+	T,F	+	+	+	+	+	0	+	+	0	0
7824T Black	+	+	+	+	+	+	T	+	+	+	+	+	0	0	+	0	0
8103 Black	+	+	+	+	+	+	T	+	+	+	+	+	0	0	0	0	0
8103 Red	+	+	+	+	+	0	T	+	+	+	+	+	0	0	0	0	0
8103 White	+	+	+	+	+	+	T	+	+	+	+	+	0	0	0	0	+
8104 Black	+	+	+	+	+	+	X	X	X	X	X	X	X	X	X	X	X

+ = Available standard cartridge and ink configuration.
 0 = Not yet qualified by Xandex. Available as a special order, subject to limited warranty conditions.
 T = with Tungsten filament
 F = with Mono-Filament
 X = Not available in filament cartridge configurations.

Inker Warranty

Seller warrants as follows:

All material supplied will conform to the description stated. All products will be free of defects in materials and workmanship under normal use for the following periods:

Stated shelf life of DM-2 Ink Cartridges:

- ◆ Markem® 6990, 6993, 6997 = Four (4) months. Five (5) days after cartridge opening
- ◆ Xandex 8103 and 8104 = Four (4) months. Three (3) days after cartridge opening.
- ◆ Xandex 7824 and 7824T = Four (4) months. Three (3) days after cartridge opening.

Pneumatic Controller = One (1) year only when clean, dry, filtered air is used, and when product is installed and operated per manufacturer's recommendations and instructions.

Ninety (90) days from the date of delivery to the customer for all other products.

Xandex makes no other warranty, express or implied, including without limitation any warranty of merchantability or of fitness for a particular purpose. Customer, OEM or Distributor's exclusive warranty shall be, at Xandex's option, to have defective product repaired or replaced, or to receive a refund of purchase price.

Xandex may, upon request, furnish to buyer such technical advice, as it may be able to supply with reference to the use by buyer of any materials delivered. Xandex assumes no liability for the advice given or results obtained. Buyer expressly agrees that it will implement any advice thus given at its own risk and agrees to indemnify and hold Xandex harmless against any liabilities, costs or expense resulting therefrom.

Xandex makes no warranty for performance, service or support of any products unless they are purchased directly from Xandex or through an authorized Xandex Distributor.

Exclusions: This warranty shall not apply to defects or damage resulting from;

- Improper or inadequate maintenance by customer, including failure to perform preventive maintenance per manufacturer's specified schedule
- Misuse or unauthorized modification
- Operation outside the environmental specifications for the product
- Improper site preparation and maintenance

Some states and provinces do not allow limitations on how long an implied warranty lasts, so the limitation or exclusion contained in this warranty may not apply to you. However, any implied warranty of merchantability or fitness is limited to the duration period of this written warranty. If you have any questions or need further assistance please contact your authorized Xandex distributor or contact our Customer Service Group.



Customer Service

1360 Redwood Way, Suite A

Petaluma, California 94954 U.S.A.

Toll Free in the United States (800) 767-9543

or (707) 763-7799 FAX (707) 763-2631

<http://www.xandexsemi.com/> email; <mailto:info@xandex.com>

System Drawings

The drawings in the list below are available in Adobe PDF format on the CD included with this manual.

Description	Drawing Number
Pneumatic Controller Assembly, Standard	350-0002
Schematic, Pneumatic Controller, Standard	950-1226
Controller Logic Board PC Assy	250-1226
24 VDC Power Supply	159-0048
Inker Assembly, Model X5100 Dimensional Drawing	900-0165
Inker Assembly, X5100	320-5100
Inker Set X5100	340-5100

This page is intentionally left blank.