



©Copyright Xandex Inc., All Rights Reserved.  
 The information disclosed herein is deemed to be confidential, proprietary, and a trade secret of Xandex, Inc. This information may not be used, reproduced or disclosed without the express prior written consent of Xandex, Inc.

## REVISIONS

REV	DESCRIPTION	CHANGE NUMBER	BY	DATE	APPROVED
D	UPDATE TITLE BLOCK	4366	MRW	11/30/17	

NOTES:

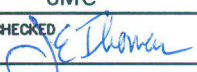
1. INKER IS FOR LTX MODELS 80 AND 44 LASER TRIMMING SYSTEMS.
2. THE MOUNTING PLATE IS CONNECTED TO THE MACHINE USING EXISTING SCREWS.
3. THIS INKER USES THE DM-S CARTRIDGE.
4. INKER ARM IS ADJUSTABLE ALONG THE "Z" AXIS BY  $\pm .187$ .
5. INKER ARM ANGLE OF APPROACH CAN BE ADJUSTED  $\pm 10^\circ$
6. ALL DIMENSIONS SHOWN WITH ADJUSTMENTS IN NEUTRAL POSITION.
7. COMPONENTS MAY BE ORDERED SEPARATELY: INKER BASE 106 (#320-0106) AND CARTRIDGE HOLDER H6-24A7 (#310-6212).

APPROVALS	DATE	ITEM	QTY	PART NUMBER	DESCRIPTION
DRAWN JMc CHECKED  ENGRG DAVE T.	01/16/97 12/7/17 01/31/97			INTERPRET DRAWING PER ASME Y14.5M-1994 TOLERANCES UNLESS OTHERWISE SPECIFIED	<div style="display: flex; align-items: center;">  <div>             1360 REDWOOD WAY, SUITE A              PETALUMA, CA 94954              (707) 763 7799           </div> </div>
NEXT ASSEMBLIES.....USED ON		DIMENSIONS ARE IN INCHES <u>DECIMALS</u> 1 PL $\pm$ FRACTIONS $\pm$ 2 PL $\pm .010$ ANGLES $\pm 1^\circ$ 3 PL $\pm .005$ 4 PL $\pm$ $\checkmark$ ALL SURFACES			
DO NOT SCALE DRAWING					
		SIZE	SCALE	SHEET	DRAWING NUMBER
		A	1/1	1 OF 2	900-0094
					REV D

© Copyright Xandex Inc., All Rights Reserved.  
 The information disclosed herein is deemed to be confidential, proprietary, and a trade secret of Xandex, Inc. This information may not be used, reproduced or disclosed without the express prior written consent of Xandex, Inc.

# REVISIONS

REV	DESCRIPTION	CHANGE NUMBER	BY	DATE	APPROVED
-	SEE SHEET 1				

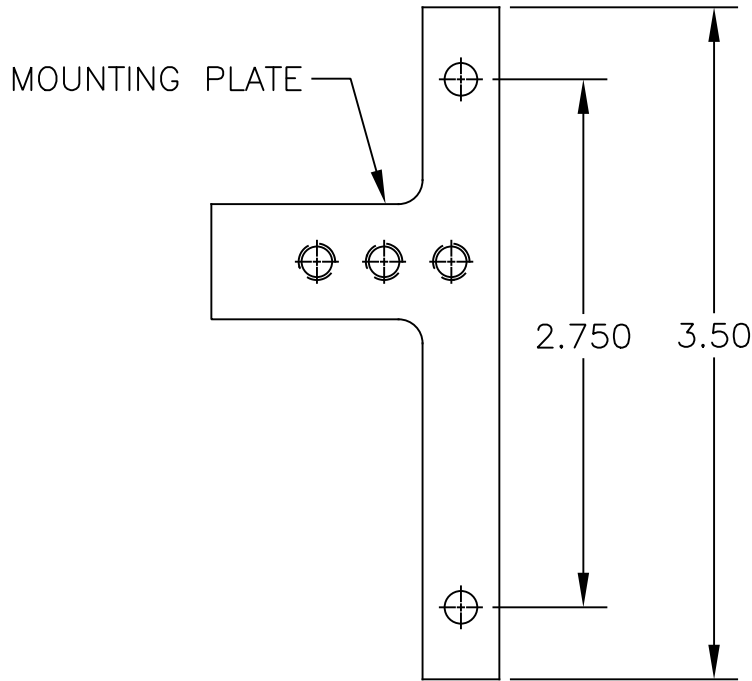
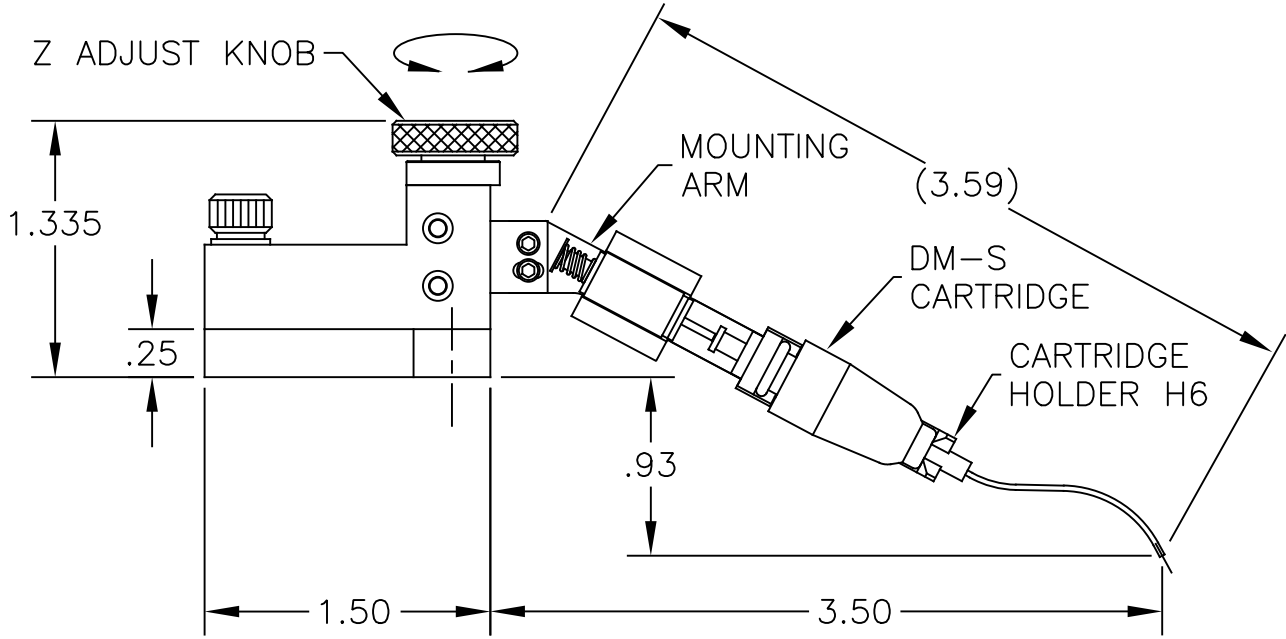

1360 REDWOOD WAY, SUITE A  
 PETALUMA, CA 94954  
 (707) 763 7799

TITLE INKER MODEL LTX106  
 (KIT #330-0106)

SEE SHEET 1 FOR NOTES  
 AND TOLERANCE INFORMATION

DO NOT SCALE DRAWING

SIZE	SCALE	SHEET
A	1/1	2 OF 2

DRAWING NUMBER
900-0094

REV
D