

REVISIONS					
REV	DESCRIPTION	CHANGE NUMBER	BY	DATE	APPROVED
B	REDRAWN ON CADD	1579	JMc	11/26/97	

NOTES:

- FOR SENTRY 15 AND 50 WITH ALL PROBERS, OVERHEAD TEST.
- MOUNTING PLATE IS CONNECTED TO INTERFACE USING TWO 2-56 X 1/4 LG PAN SLOT HD SCREWS.
- HEX KEY WRENCHES ARE SUPPLIED WITH THIS UNIT.
- THIS INKER USES THE DM-1 AND DM-1.25 CARTRIDGES ONLY.
- ALL DIMENSIONS SHOWN WITH ADJUSTMENTS IN NEUTRAL POSITION.
- HOLDER ALLOWS ADJUSTMENT OF "Z" AXIS BY MOVING IN SLIDE BRACKET.
- COMPONENTS MAY BE ORDERED SEPARATELY: INKER BASE B400 (#320-0400) AND CARTRIDGE HOLDER H7-24E7 (#310-7252).
- FOR 5 MIL CARTRIDGES, RETROFIT CARTRIDGE HOLDER USING PLUNGER STOP ASSEMBLY #210-0016.

FILE NAME	9000105B	ITEM	QTY	PART NUMBER	DESCRIPTION
APPROVALS	DATE	INTERPRET DRAWING PER ANSI Y14.5 - 1982			
DRAWN	JMc	11/26/97			
CHECKED		TOLERANCES UNLESS OTHERWISE SPECIFIED			
ENGR		DIMENSIONS ARE IN INCHES			
ENGR		DECIMALS			
NEXT ASSEMBLIES.....USED ON		1 PL ± FRACTIONS ±		DO NOT SCALE DRAWING	
		2 PL ±.010 ANGLES ±1°		SIZE SCALE SHEET DRAWING NUMBER REV	
		3 PL ±.005 63/ ALL SURFACES		A 1/1 1 of 2 900-0105 B	
		4 PL ±			



TITLE INKER MODEL 406 (KIT #330-0406)

REVISIONS					
REV	DESCRIPTION	CHANGE NUMBER	BY	DATE	APPROVED
-	SEE SHEET 1				

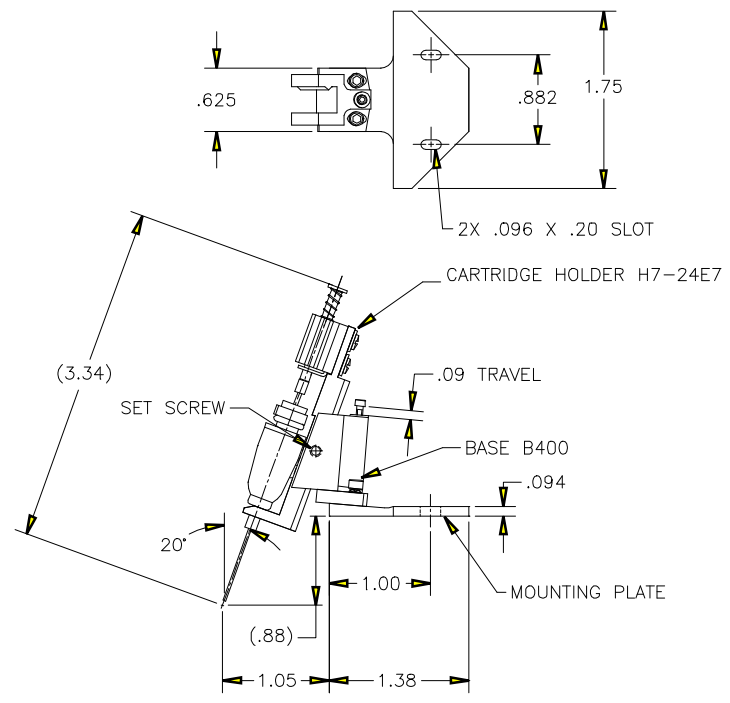

FILE NAME		9000105B		DO NOT SCALE DRAWING	
SIZE	SCALE	SHEET	DRAWING NUMBER	REV	
A	1/1	2 of 2	900-0105	B	



TITLE INKER MODEL EG 406 (KIT #330-0406)