

REVISIONS					
REV	DESCRIPTION	ECO	BY	DATE	APPROVED
A	INITIAL RELEASE	564	JT	3/18/93	

NOTES:

1. INKER IS DESIGNED FOR USE ON TRILLIUM MICROMASTER AND DELTA-MASTER TEST HEADS. TEST HEAD MUST BE OUTFITTED WITH THE BLACK PLASTIC GUARD (TRILLIUM PART NUMBER A-530419-01).
2. FOR 1" POGO STACKS, ORDER INKER KIT X3100 (PART NUMBER 340-3100). FOR 1.5" POGO STACKS, ORDER INKER KIT X3110 (PART NUMBER 340-3110). FOR KLA VERSIONS USING 1.5" POGO STACKS, ORDER INKER KIT X3200 (PART NUMBER 340-3200). INKERS CAN BE ADAPTED TO 1" OR 1.5" POGO STACKS BY CHANGING THE CARTRIDGE HOLDER MOUNTING ARMS. FOR CONVERSION FROM 1" TO 1.5", ORDER ARM 120-0030. FOR CONVERSION FROM 1.5" TO 1", ORDER ARM 120-0029.
3. X, Y ADJUSTMENT IS $\pm .062$. Z ADJUSTMENT CAPABILITY IS $\pm .125$ PLUS AN ADDITIONAL $.10$ ADJUSTMENT TO ACCOMODATE PROBE TIPS LONGER THAN $.080$.
4. INKER CAN BE USED WITH EITHER:
 THE OLYMPUS SZ SERIES MICROSCOPE WITH A 0.3X OR 0.4X OBJECTIVE LENS. MINIMUM WORKING DISTANCE IS 210mm (8.27").
 OR:
 THE OPTEM HF-65 MICROSCOPE WITH A 0.7X-4.5X OBJECTIVE LENS. MINIMUM WORKING DISTANCE IS 90mm (3.50").

FILE NAME 9000146A	ITEM	QTY	PART NUMBER	DESCRIPTION
UNLESS OTHERWISE SPECIFIED DIMENSIONS ARE IN INCHES TOLERANCES ON: 2 PL DECIMALS \pm 3 PL DECIMALS \pm ANGLES \pm FRACTIONS \pm MATERIAL: HEAT TREAT OR PLATING	SIGNATURES J. TEMPLETON	DATE 3/18/93	XANDEX INC.	1125 N. McDOWELL BLVD. PETALUMA, CA 95954 (707) 763 7799
	ENGRG		TITLE INKER SERIES 3000, REMOTE ADJUST PNEUMATIC	
	ISSUED		SIZE A	FSCM NO
	NEXT ASSY'S		DWG NO 900-0146	REV A
			SCALE 1/2	SHEET 1 OF 2

REVISIONS					
REV	DESCRIPTION	ECO	BY	DATE	APPROVED
A	SEE SHEET 1				

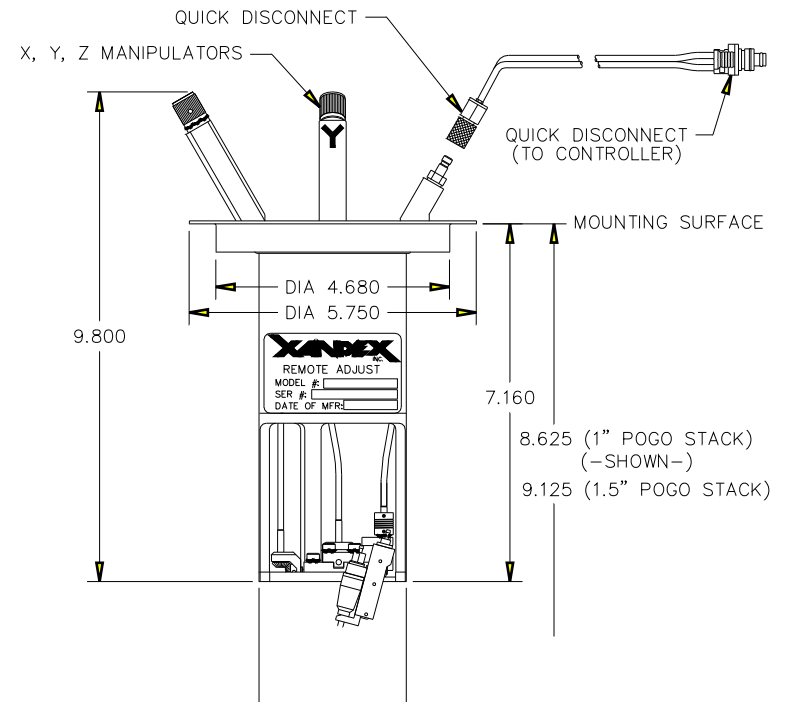

XANDEX INC.	TITLE INKER SERIES 3000, REMOTE ADJUST PNEUMATIC
1125 N. McDOWELL BLVD. PETALUMA, CA 95954 (707) 763 7799	SIZE A
	FSCM NO
	DWG NO 900-0146
	REV A
SCALE 1/2	FILE NAME 9000146A
	SHEET 2 OF 2