

©Copyright Xandex Inc., All Rights Reserved.
 The information disclosed herein is deemed to be confidential, proprietary, and a trade secret of Xandex, Inc. This information may not be used, reproduced or disclosed without the express prior written consent of Xandex, Inc.

REVISIONS

REV	DESCRIPTION	CHANGE NUMBER	BY	DATE	APPROVED
A	INITIAL RELEASE	1330	DT	11/04/96	DT
B	REV TO MAG BASE	1801	RAP	04/30/99	JG
C	REV TO NEW DWG FORMAT	D137	RAP	06/01/99	JG

NOTES:

1. INKER FOR KLA 1007 SERIES PROBER, OFF LINE PROBING.
2. THIS INKER USES THE DM-2 CARTRIDGE ONLY.
3. INKER ARM IS ADJUSTABLE ALONG THE "Z" AXIS BY ±.188.
4. JOYSTICK PROVIDES "X" AND "Y" AXIS MOVEMENT AT THE TIP OF THE CARTRIDGE NEEDLE.
5. ALL DIMENSIONS SHOWN WITH ADJUSTMENTS IN NEUTRAL POSITION.
6. INKER MOUNTS TO THE PROBER USING (2) M3 X 0.5 X 6MM PAN HEAD SCREWS (SUPPLIED).
7. ORDER KIT NUMBER 340-1202.

APPROVALS	DATE	ITEM	QTY	PART NUMBER	DESCRIPTION										
DRAWN D. TEGLIA	11/04/96			INTERPRET DRAWING PER ASME Y14.5M-1994	 1125 N. McDOWELL BLVD. PETALUMA, CA 94954 (707) 763 7799										
CHECKED <i>Milled</i>	6/2/99			TOLERANCES UNLESS OTHERWISE SPECIFIED											
O.C. <i>288</i>	6/3/99			DIMENSIONS ARE IN INCHES	TITLE PNEUMATIC INKER X1202										
ENGRG D. TEGLIA	11/05/96			DECIMALS	DO NOT SCALE DRAWING										
MFG ENGRG <i>[Signature]</i>	6/3/99			1 PL ± FRACTIONS ± 2 PL ±.010 ANGLES ±1° 3 PL ±.005 4 PL ± 63/ ALL SURFACES											
NEXT ASSEMBLIES..... USED ON 340-1202					<table border="1" style="width: 100%; border-collapse: collapse;"> <tr> <th style="width: 10%;">SIZE</th> <th style="width: 10%;">SCALE</th> <th style="width: 10%;">SHEET</th> <th style="width: 30%;">DRAWING NUMBER</th> <th style="width: 10%;">REV</th> </tr> <tr> <td>A</td> <td>1/1</td> <td>1 OF 2</td> <td>900-0182</td> <td>C</td> </tr> </table>	SIZE	SCALE	SHEET	DRAWING NUMBER	REV	A	1/1	1 OF 2	900-0182	C
SIZE	SCALE	SHEET	DRAWING NUMBER	REV											
A	1/1	1 OF 2	900-0182	C											

© Copyright Xandex Inc., All Rights Reserved.
 The information disclosed herein is deemed to be confidential, proprietary, and a trade secret of Xandex, Inc. This information may not be used, reproduced or disclosed without the express prior written consent of Xandex, Inc.

REVISIONS

REV	DESCRIPTION	CHANGE NUMBER	BY	DATE	APPROVED
-	SEE SHEET 1	-	-	-	-

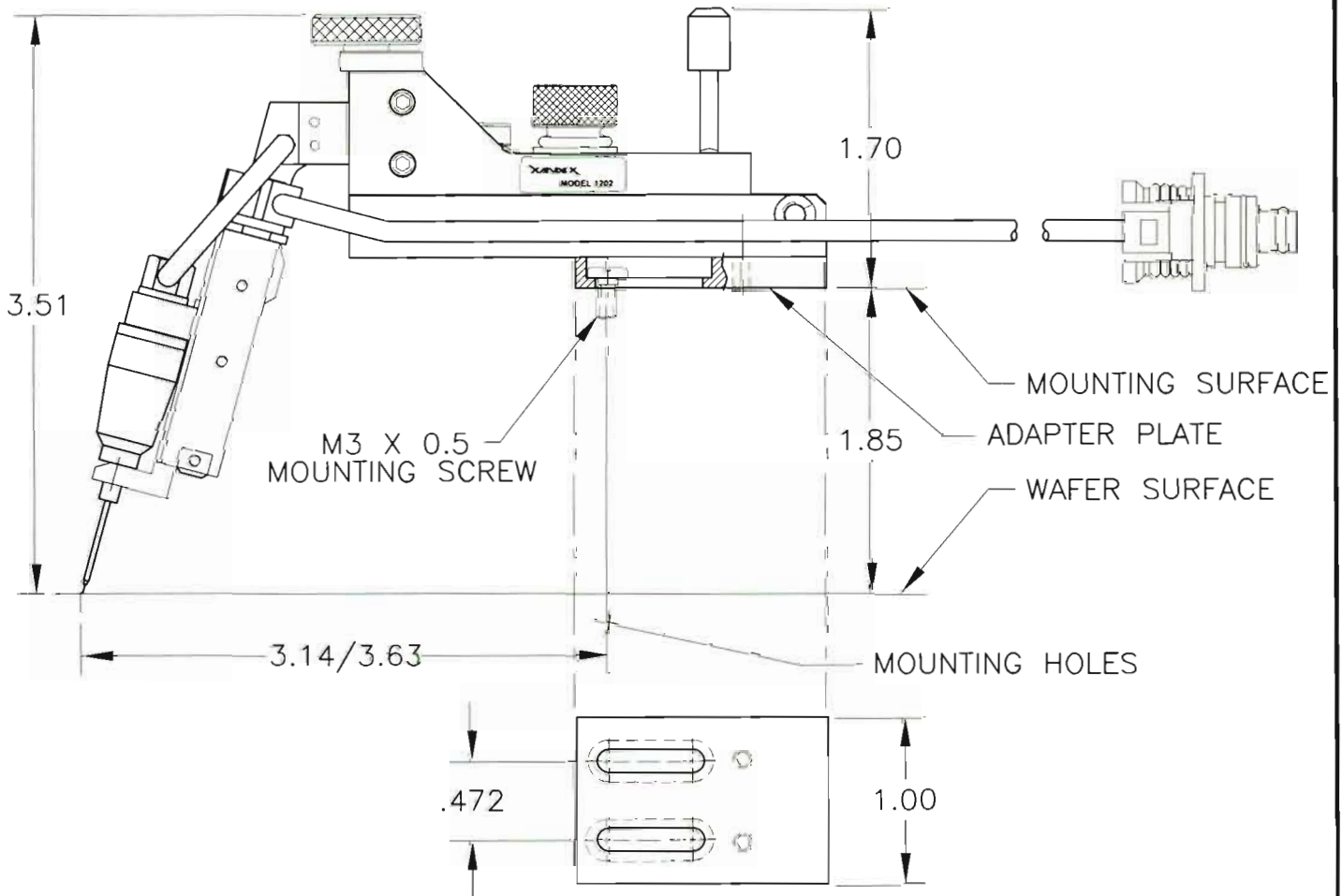
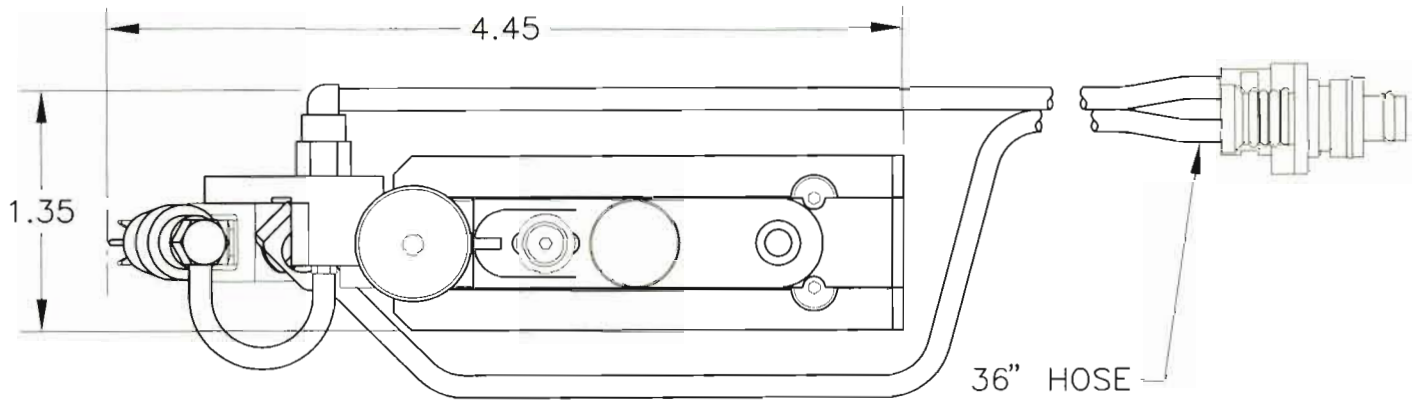

1125 N. McDOWELL BLVD.
 PETALUMA, CA 94954
 (707) 763 7799

TITLE: PNEUMATIC INKER X1202

SEE SHEET 1 FOR NOTES AND TOLERANCE INFORMATION

DO NOT SCALE DRAWING

SIZE: A	SCALE: 1/1	SHEET: 2 OF 2
---------	------------	---------------

DRAWING NUMBER: 900-0182

REV: C
