

©Copyright Xandex Inc., All Rights Reserved.
 The information disclosed herein is deemed to be confidential, proprietary, and a trade secret of Xandex, Inc. This information may not be used, reproduced or disclosed without the express prior written consent of Xandex, Inc.

REVISIONS

REV	DESCRIPTION	ECO	BY	DATE	APPROVED
A	INITIAL RELEASE	0335	JG	9/11/97	

NOTES:

1. INKER USES STANDARD DM-2 CARTRIDGES.
2. INKER IS DESIGNED FOR USE ON TERADYNE A570, A575, A580 & A585 TESTERS ON AN EG 2000 SERIES PROBER. TEST HEAD MUST BE RETRO-FITTED WITH THE XANDEX ADAPTER ASSEMBLY, PART NUMBER 220-0039. NO OTHER MODIFICATION TO THE TESTER IS NECESSARY.
3. AS BUILT, THE INKER IS DESIGNED TO WORK WITH A STANDARD TERADYNE INTERFACE. AN ADDITIONAL ADJUSTMENT OF .10 HIGHER, OR .50 LOWER TO ACCOMMODATE CUSTOM INTERFACES IS EASILY ACCOMPLISHED BY THE REMOVAL OF TWO SCREWS ON THE CARTRIDGE HOLDER ARM.
4. THE ADAPTER ASSEMBLY IS DESIGNED TO ALLOW EASY INSTALLATION OR REMOVAL OF THE INKER, BY UTILIZING TWO STAINLESS STEEL SHAFTS TO GUIDE THE INKER IN AND OUT OF THE TESTHEAD. THE ADAPTER IS ALSO DESIGNED TO ALLOW "LEVELING" OF THE INKER TO ACCOMMODATE ANY LACK OF PLANARITY IN THE TESTHEAD STRUCTURE.
5. BECAUSE OF THE EXTREME DEPTH OF THE TESTHEAD, AND CONSEQUENT EXTRA LONG INKER, A HANDLE HAS BEEN PROVIDED ON THE INKER FOR EASIER INSTALLATION AND REMOVAL.
6. A NEW DESIGN UTILIZING SOLID SHAFTING, PROVIDES INCREASED RELIABILITY, IMPROVED X/Y/Z ACTUATION, AND EASY ACCESS ADJUSTMENT KNOBS.
7. X, Y ADJUSTMENT IS ± 0.062 . Z ADJUSTMENT CAPABILITY IS $\pm .125$.
8. INKER IS DESIGNED FOR USE WITH THE OPTEM HF-65 MICROSCOPE WITH A .525X-3.37X OBJECTIVE LENS. MINIMUM WORKING DISTANCE IS 114mm (4.50").
9. ORDER INKER KIT X3307 (PART NUMBER 340-3307).

FILE NAME	9000198A	ITEM	QTY	PART NUMBER	DESCRIPTION
APPROVALS	DATE	INTERPRET DRAWING			
BY JMG	9/11/97	PER ANSI Y14.5 - 1982			
SECRETED		TOLERANCES			
DWG		UNLESS OTHERWISE SPECIFIED			
ENGR		DIMENSIONS ARE IN INCHES			
MFG ENGR		DECIMALS			
NEXT ASSEMBLIES.....USED ON					
340-3307					
		1 PL \pm	FRACTIONS \pm		
		2 PL \pm	ANGLES \pm		
		3 PL \pm			
		4 PL \pm	<input checked="" type="checkbox"/> ALL SURFACES		

XANDEX INC.
 1125 N. McDOWELL BLVD.
 PETALUMA, CA 95954
 (707) 763 7799

TITLE
 INKER SERIES X3307 (EG)
 TERADYNE A575 R/A

DO NOT SCALE DRAWING

SIZE	SCALE	SHEET	DRAWING NUMBER	REV
A	1/2	1 of 4	900-0198	A

REVISIONS

©Copyright Xandex Inc., All Rights Reserved.
 The information disclosed herein is deemed to be confidential, proprietary, and a trade secret of Xandex, Inc. This information may not be used, reproduced or disclosed without the express prior written consent of Xandex, Inc.

REV	DESCRIPTION	ECO	BY	DATE	APPROVED
-	SEE SHEET 1				

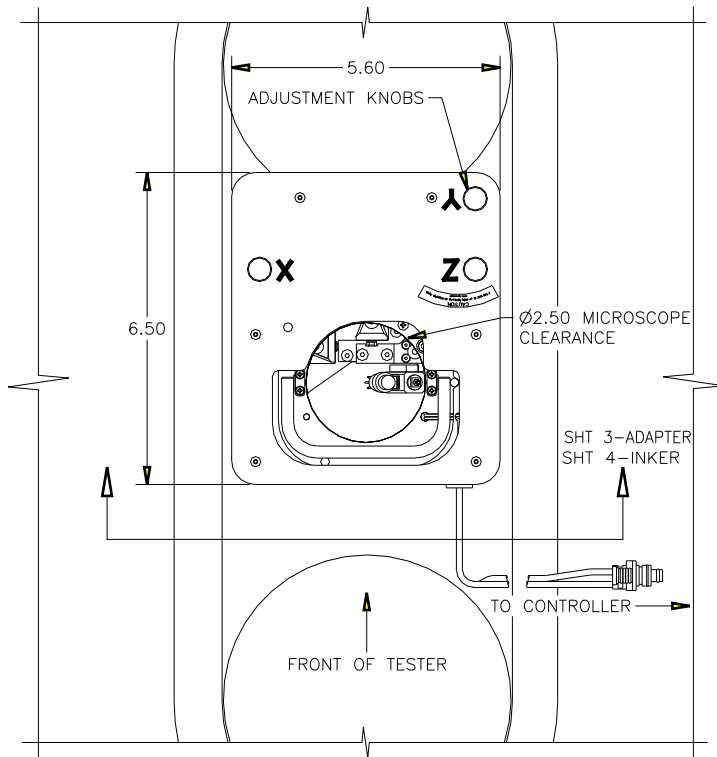

VIEW LOOKING AT TOP OF TESTER WITH INKER INSTALLED

XANDEX INC.
 1125 N. McDOWELL BLVD.
 PETALUMA, CA 95954
 (707) 763 7799

TITLE
 INKER SERIES X3307 (EG)
 TERADYNE A575 R/A

FILE NAME	9000198A	DO NOT SCALE DRAWING			
SIZE	SCALE	SHEET	DRAWING NUMBER	REV	
A	1/2	2 of 4	900-0198	A	

©Copyright Xandex Inc., All Rights Reserved.
 The information disclosed herein is deemed to be confidential, proprietary, and a trade secret of Xandex, Inc. This information may not be used, reproduced or disclosed without the express prior written consent of Xandex, Inc.

REVISIONS

REV	DESCRIPTION	ECO	BY	DATE	APPROVED
-----	-------------	-----	----	------	----------

-	SEE SHEET 1				
---	-------------	--	--	--	--

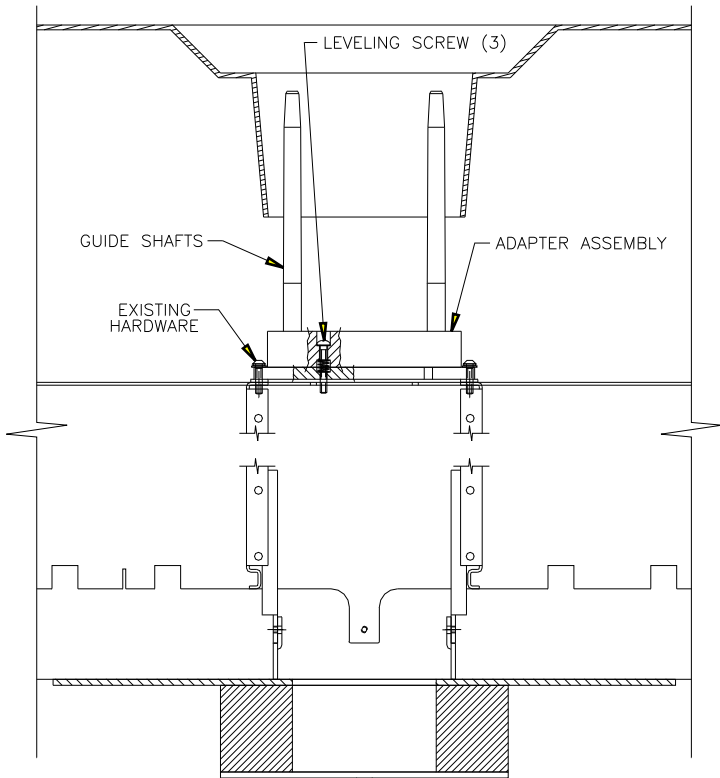

1125 N. McDOWELL BLVD.
 PETALUMA, CA 95954
 (707) 763 7799

TITLE INKER SERIES X3307 (EG)
 TERADYNE A575 R/A

FILE NAME 9000198A		DO NOT SCALE DRAWING			
SIZE A	SCALE 1/2	SHEET 3 OF 4	DRAWING NUMBER 900-0198	REV A	

©Copyright Xandex Inc., All Rights Reserved.
 The information disclosed herein is deemed to be confidential, proprietary, and a trade secret of Xandex, Inc. This information may not be used, reproduced or disclosed without the express prior written consent of Xandex, Inc.

REVISIONS

REV	DESCRIPTION	ECO	BY	DATE	APPROVED
-----	-------------	-----	----	------	----------

-	SEE SHEET 1				
---	-------------	--	--	--	--

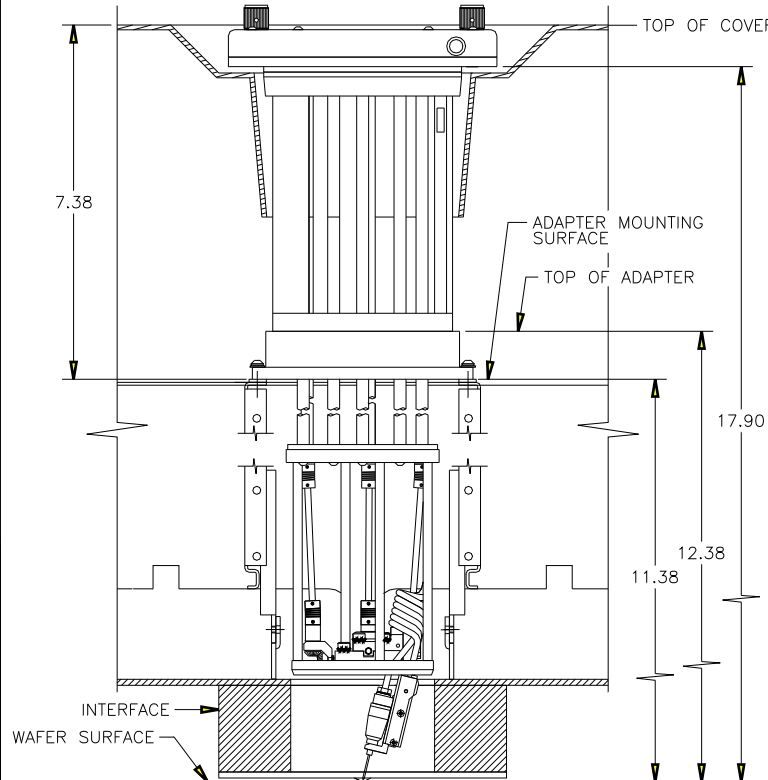

1125 N. McDOWELL BLVD.
 PETALUMA, CA 95954
 (707) 763 7799

TITLE INKER SERIES X3307 (EG)
 TERADYNE A575 R/A

FILE NAME 9000198A		DO NOT SCALE DRAWING			
SIZE A	SCALE 1/2	SHEET 4 OF 4	DRAWING NUMBER 900-0198	REV A	