

© Copyright Xandex Inc., All Rights Reserved. The information disclosed herein is deemed to be confidential, proprietary, and a trade secret of Xandex, Inc. This information may not be used, reproduced or disclosed without the expressed prior written consent of Xandex, Inc.

REVISIONS					
REV	DESCRIPTION	CHANGE NUMBER	BY	DATE	APPROVED
A	INITIAL RELEASE	4566	MRW	12/07/22	

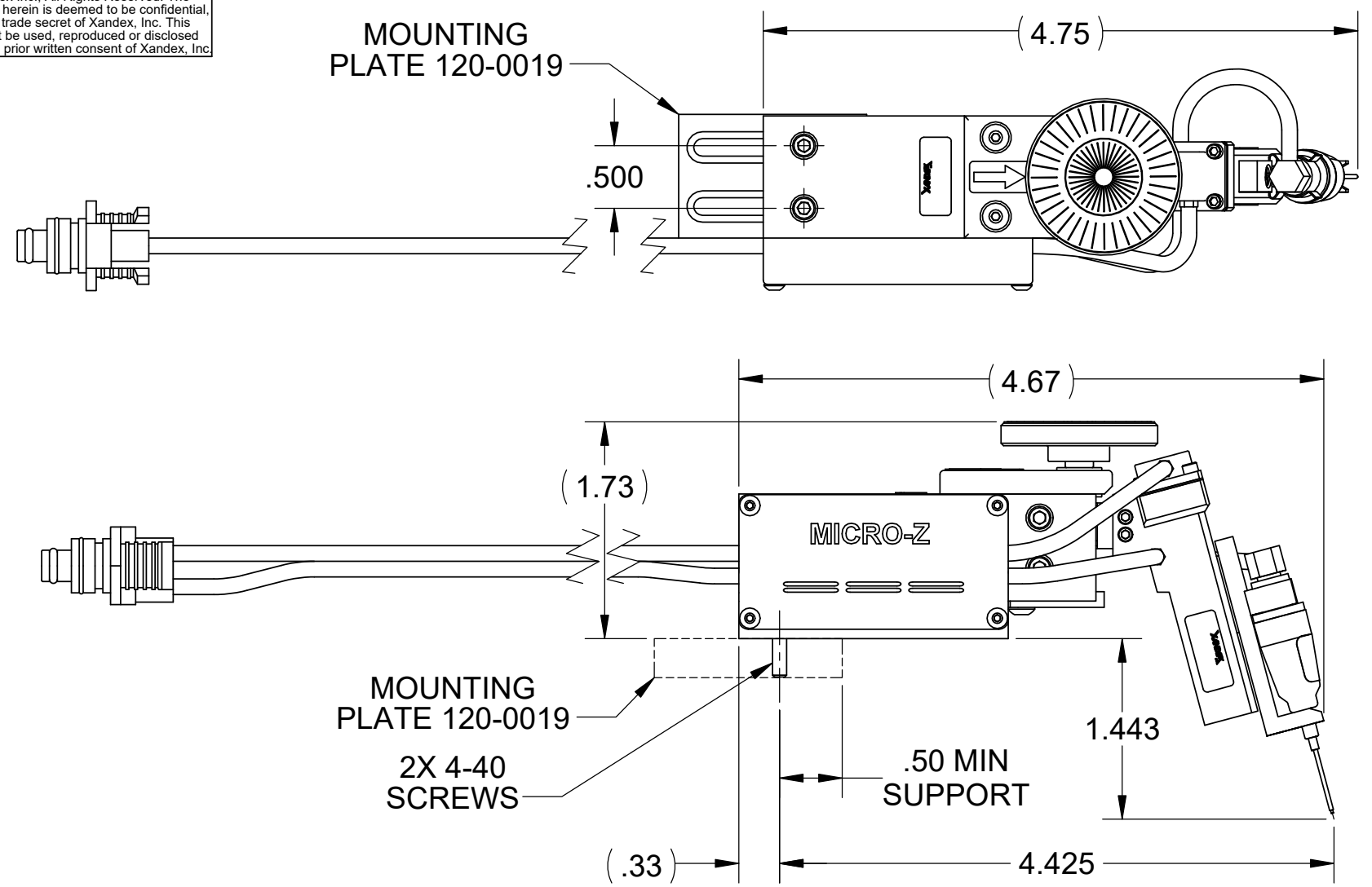

NOTES:

1. IN FACTORY SETTING, SHUTTLE TRAVELS .050 NOMINAL FROM POSITION SHOWN TO DEPOSIT INK ON WAFER.
2. INKER HAS VERTICAL (Z) ADJUSTMENT CAPABILITY OF ±.18 IN INCREMENTS OF .0005, FROM NOMINAL POSITION SHOWN.
3. INKER USES DM-2 TYPE INK CARTRIDGES.
4. FOR KLA PROBERS: INSTALL INKER MOUNTING PLATE (120-0019) TO PROBER USING (2) M3.5 X 6MM LONG PAN HEAD SCREWS (SUPPLIED). MOUNT INKER ASSEMBLIES TO MOUNTING PLATE USING (2) 4-40 X 1-1/4 LONG SOCKET HEAD SCREWS (SUPPLIED).
5. FOR ALL OTHER PROBERS: MOUNT INKER ASSEMBLIES TO PROBER USING (2) 4-40 X 1- 1/4 LONG SOCKET HEAD SCREWS (SUPPLIED).
6. REFER TO THE TABLE TO ORDER THE 340-XXXX KIT FOR THE CORRESPONDING PROBER INTERFACE.

CONFIGURATION TABLE							
WEIGHT GRAMS	PART NUMBER	DESCRIPTION	CABLE P/N	CABLE DESCRIPTION	INCLUDE MOUNTING PLATE 120-0019	SHUTTLE P/N	REV
207	340-7110-01	SET-INKER X7111 EG MANUAL MICRO Z	210-0109	A-C	No	316-0010 (36")	A
207	340-7110-02	SET-INKER X7112 KLA MANUAL MICRO Z	210-0110	C-C	Yes	316-0010 (36")	A
207	340-7110-03	SET-INKER X7113 TSK MANUAL MICRO Z	210-0114	J-C	No	316-0010 (36")	A
207	340-7110-04	SET-INKER X7114 P8 MANUAL MICRO Z	210-0120	P8-C	No	316-0010 (36")	A
215	340-7110-05	SET-INKER X7115 MANUAL MICRO Z	210-0113	C	No	316-0012 (60")	A

APPROVALS	DATE	INTERPRET DRAWING PER ASME Y14.5M-1994	1360 REDWOOD WAY, SUITE A PETALUMA, CA 94954 (707) 763-7799
DRAWN	MRW 6/2/2022		
CHECKED	File Approved per DCA#1-\$	TOLERANCES	TITLE OD DWG INKER KIT, MANUAL MICRO-Z
ENGRG	K.F. FEBLES 6/2/2022	UNLESS OTHERWISE SPECIFIED DIMENSIONS ARE IN INCHES	
NEXT ASSEMBLIES.....USED ON		DECIMALS 1 PL ±.1 2 PL ±.03 3 PL ±.010	FRACTIONS ± ANGLES ± 1° 63° ALL SURFACES
THIRD ANGLE PROJECTION		DO NOT SCALE DRAWING	
SIZE	SCALE	SHEET	DRAWING NUMBER
B	4:5	1 OF 1	900-7110
			REV
			A