

©Copyright Xandex Inc., All Rights Reserved.
 The information disclosed herein is deemed to be confidential, proprietary, and a trade secret of Xandex, Inc. This information may not be used, reproduced or disclosed without the express prior written consent of Xandex, Inc.

REVISIONS

REV	DESCRIPTION	CHANGE NUMBER	BY	DATE	APPROVED
E	UPDATE TITLE BLOCK	4366	MRW	11/30/17	<i>[Signature]</i>

NOTES:

1. FOR USE WITH TOKYO SEIMITSU PROBER MODELS 30XX, 50XX, 60XX, AND 70XX. CABLED PROBING APPLICATION.
2. MOUNTING PLATE IS CONNECTED TO PROBER USING TWO #4-40 X 1/4 FLAT HD SCREWS.
3. THIS INKER USES THE DM-1 AND DM-1.25 CARTRIDGES ONLY.
4. INKER ARM IS ADJUSTABLE ALONG THE "Z" AXIS BY ±.187.
5. THE MOUNTING ARM ANGLE OF APPROACH CAN BE ADJUSTED ± 10°.
6. ALL DIMENSIONS SHOWN WITH ADJUSTMENTS IN NEUTRAL POSITION.
7. HOLDER ALLOWS ADDITIONAL ADJUSTMENT OF "Z" AXIS BY MOVING SLIDE BRACKET.
8. COMPONENTS MAY BE ORDERED SEPARATELY: INKER BASE 104 (#320-0104) AND CARTRIDGE HOLDER H1-24Z7 (#310-1292). FOR 5 MIL CARTRIDGES USE HOLDER H2-24Z7 (#310-2292).
9. FOR 5 MIL CARTRIDGES, RETROFIT CARTRIDGE HOLDER USING PLUNGER STOP ASSEMBLY #210-0016.

APPROVALS	DATE	ITEM	QTY	PART NUMBER	DESCRIPTION
DRAWN HOLLY G.	10/25/95	INTERPRET DRAWING PER ASME Y14.5M-1994			 1360 REDWOOD WAY, SUITE A PETALUMA, CA 94954 (707) 763 7799
CHECKED <i>[Signature]</i>	12/7/17	TOLERANCES UNLESS OTHERWISE SPECIFIED			
ENGRG DAVE T.	04/08/96	DIMENSIONS ARE IN INCHES <u>DECIMALS</u>			TITLE INKER MODEL TSK 104 (KIT #330-3104)
NEXT ASSEMBLIES.....USED ON		1 PL ± FRACTIONS ±			DO NOT SCALE DRAWING
		2 PL ± ANGLES ±			SIZE A SCALE 1/1 SHEET 1 OF 2 DRAWING NUMBER 900-0092 REV E
		3 PL ±			
		4 PL ± <input checked="" type="checkbox"/> ALL SURFACES			

© Copyright Xandex Inc., All Rights Reserved.
 The information disclosed herein is deemed to be confidential, proprietary, and a trade secret of Xandex, Inc. This information may not be used, reproduced or disclosed without the express prior written consent of Xandex, Inc.

REVISIONS

REV	DESCRIPTION	CHANGE NUMBER	BY	DATE	APPROVED
-	SEE SHEET 1				

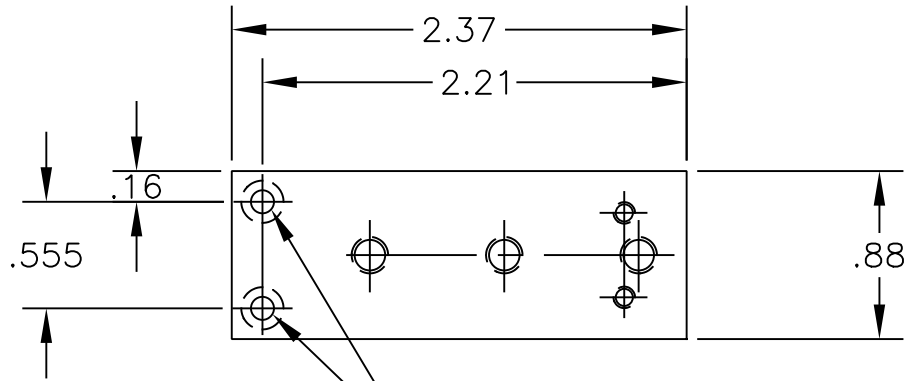
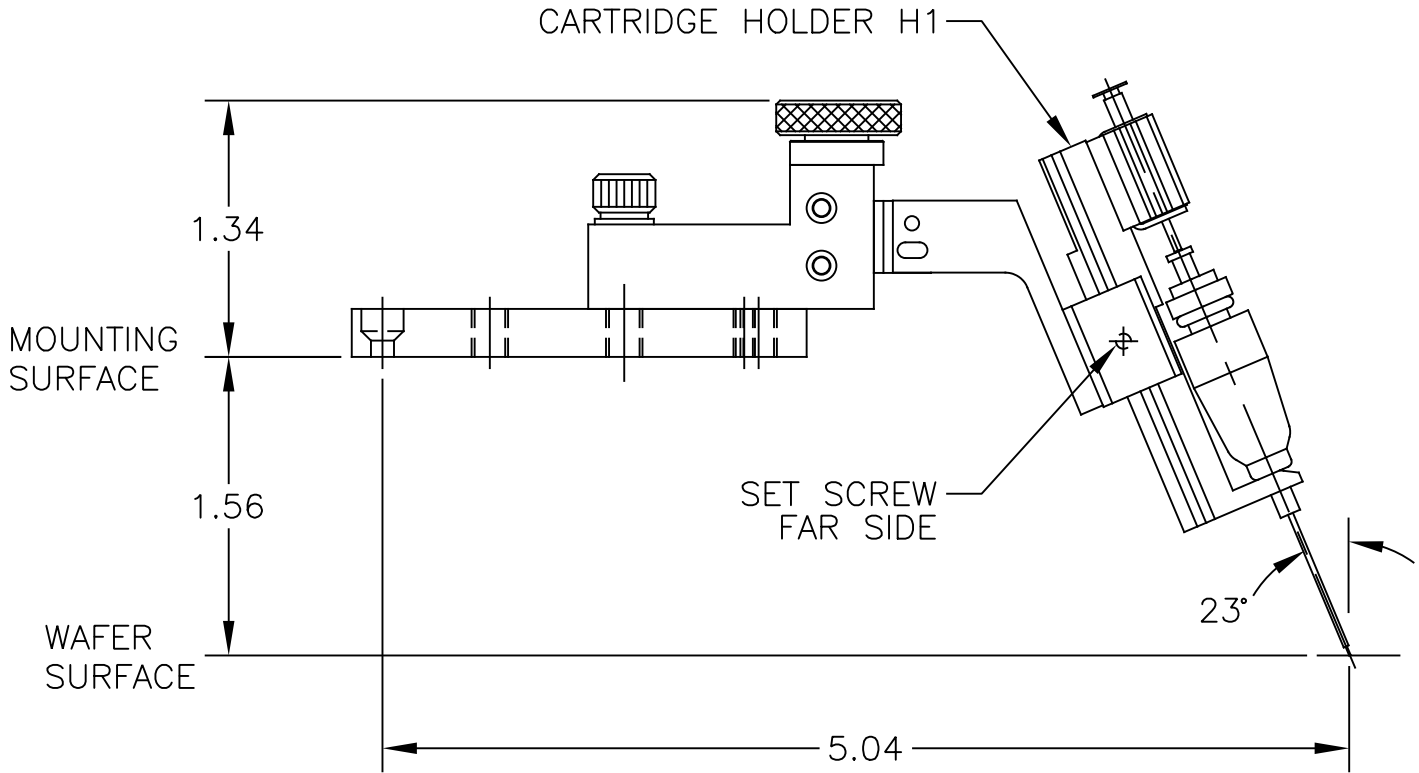

MOUNTING HOLES



1360 REDWOOD WAY, SUITE A
 PETALUMA, CA 94954
 (707) 763 7799

TITLE INKER MODEL TSK 104
 (KIT #330-3140)

SEE SHEET 1 FOR NOTES AND TOLERANCE INFORMATION			DO NOT SCALE DRAWING	
SIZE A	SCALE 1/1	SHEET 2 OF 2	DRAWING NUMBER 900-0092	REV E