

©Copyright Xandex Inc., All Rights Reserved. The information disclosed herein is deemed to be confidential, proprietary, and a trade secret of Xandex, Inc. This information may not be used, reproduced or disclosed without the express prior written consent of Xandex, Inc.					
REVISIONS					
REV	DESCRIPTION	CHANGE NUMBER	BY	DATE	APPROVED
B	REDRAWN ON CADD	1409	UMc	02/03/97	

NOTES:

- FOR USE WITH LTX TRILLIUM TESTER, OVERHEAD TEST APPLICATION.
ELECTROGLAS PROBER: INKER MODEL EG 402 (KIT #330-0402)
KLA/TEL PROBERS: INKER MODEL KLA 402 (KIT #330-1402)
- MOUNTING RING IS CONNECTED TO INTERFACE USING TWO 4-40 X 1/4 SOC. HD. CAP SCREWS.
- HEX KEY WRENCHES ARE SUPPLIED WITH THIS UNIT.
- THIS INKER USES THE DM-1 AND DM-1.25 CARTRIDGES ONLY.
- ALL DIMENSIONS SHOWN WITH ADJUSTMENTS IN NEUTRAL POSITION.
- HOLDER ALLOWS ADJUSTMENT OF "Z" AXIS BY MOVING IN SLIDE BRACKET.
- COMPONENTS MAY BE ORDERED SEPARATELY: INKER BASE 402 (#320-0402) AND CARTRIDGE HOLDER H7-24E7 (#310-7252).
- FOR 5 MIL CARTRIDGES, RETROFIT CARTRIDGE HOLDER USING PLUNGER STOP ASSEMBLY #210-0016.

FILE NAME	9000101B	ITEM	QTY	PART NUMBER	DESCRIPTION
APPROVALS	DATE	INTERPRET DRAWING		 1125 N. McDOWELL BLVD. PETALUMA, CA 95954 (707) 763 7799	
DRAWN	02/03/97	PER ANSI Y14.5 - 1982			
CHECKED		TOLERANCES		TITLE INKER MODEL 402	
ALL		UNLESS OTHERWISE SPECIFIED			
ENGRG	DAVE T. 2/3/97	DIMENSIONS ARE IN INCHES		DO NOT SCALE DRAWING SIZE SCALE SHEET DRAWING NUMBER REV A 1/1 1 of 2 900-0101 B	
ENGRG		DECIMALS			
NEXT ASSEMBLIES.....USED ON		1 PL ±	FRACTIONS ±		
		2 PL ±.010	ANGLES ±1°		
		3 PL ±.005	63/ ALL SURFACES		
		4 PL ±			

©Copyright Xandex Inc., All Rights Reserved. The information disclosed herein is deemed to be confidential, proprietary, and a trade secret of Xandex, Inc. This information may not be used, reproduced or disclosed without the express prior written consent of Xandex, Inc.					
REVISIONS					
REV	DESCRIPTION	CHANGE NUMBER	BY	DATE	APPROVED
-	SEE SHEET 1				

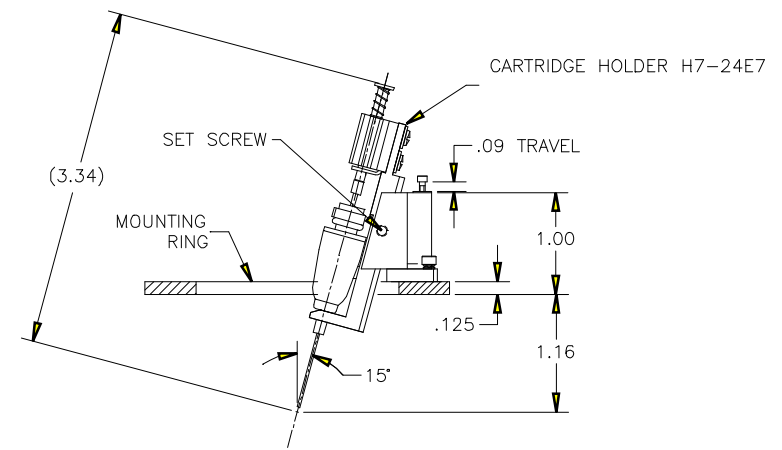
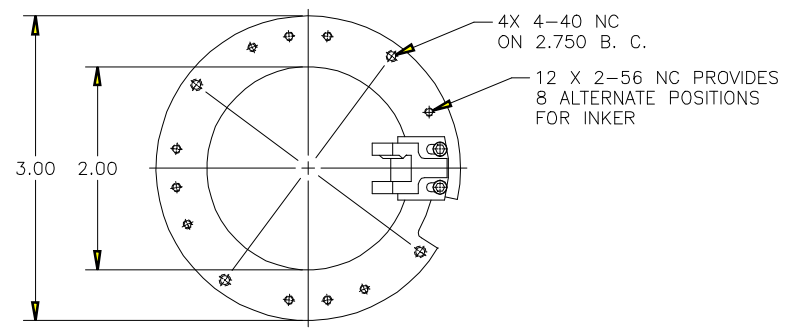

		TITLE INKER MODEL 402	
FILE NAME	9000101B	DO NOT SCALE DRAWING	
SIZE	SCALE	SHEET	DRAWING NUMBER
A	1/1	2 of 2	900-0101
			REV
			B