

©Copyright Xandex Inc., All Rights Reserved.
 The information disclosed herein is deemed to be confidential, proprietary, and a trade secret of Xandex, Inc. This information may not be used, reproduced or disclosed without the express prior written consent of Xandex, Inc.

REVISIONS

REV	DESCRIPTION	CHANGE NUMBER	BY	DATE	APPROVED
B	REDRAWN ON CADD	1409	JMc	02/03/97	

NOTES:

- FOR USE WITH MEGATEST MEGA ONE MODEL TESTER, OVERHEAD TEST APPLICATION.
 ELECTROGLAS PROBERS: INKER MODEL EG 403 (KIT #330-0403)
 KLA/TEL PROBERS: INKER MODEL KLA 403 (KIT #330-1403)
- MOUNTING BRACKET IS CONNECTED TO INTERFACE USING TWO 2-56 X 1/4 LG. SOC. HD. CAP SCREWS.
- HEX KEY WRENCHES ARE SUPPLIED WITH THIS UNIT.
- THIS INKER USES THE DM-1 AND DM-1.25 CARTRIDGES ONLY.
- ALL DIMENSIONS SHOWN WITH ADJUSTMENTS IN NEUTRAL POSITION.
- HOLDER ALLOWS ADJUSTMENT OF "Z" AXIS BY MOVING IN SLIDE BRACKET.
- COMPONENTS MAY BE ORDERED SEPARATELY: INKER BASE 403 (#320-0403) AND CARTRIDGE HOLDER H7-24H7 (#310-7272).
- FOR 5 MIL CARTRIDGES, RETROFIT CARTRIDGE HOLDER USING PLUNGER STOP ASSEMBLY #210-0016.

FILE NAME	9000102B	ITEM	QTY	PART NUMBER	DESCRIPTION
APPROVALS	DATE	INTERPRET DRAWING			1125 N. McDOWELL BLVD. PETALUMA, CA 95954 (707) 763 7799
DRAWN	02/03/97	PER ANSI Y14.5 - 1982			
CHECKED		TOLERANCES		TITLE	INKER MODEL 403
DWG		UNLESS OTHERWISE SPECIFIED		DO NOT SCALE DRAWING	
APPROVED	DAVE T.	DIMENSIONS ARE IN INCHES		SIZE	A
DWG	2/3/97	DECIMALS		SCALE	1/1
NEXT ASSEMBLIES.....USED ON		1 PL ±	FRACTIONS ±	SHEET	1 OF 2
		2 PL ± .010	ANGLES ± 1°	DRAWING NUMBER	900-0102
		3 PL ± .005	63 / ALL SURFACES	REV	B
		4 PL ±			

©Copyright Xandex Inc., All Rights Reserved.
 The information disclosed herein is deemed to be confidential, proprietary, and a trade secret of Xandex, Inc. This information may not be used, reproduced or disclosed without the express prior written consent of Xandex, Inc.

REVISIONS

REV	DESCRIPTION	CHANGE NUMBER	BY	DATE	APPROVED
-	SEE SHEET 1				

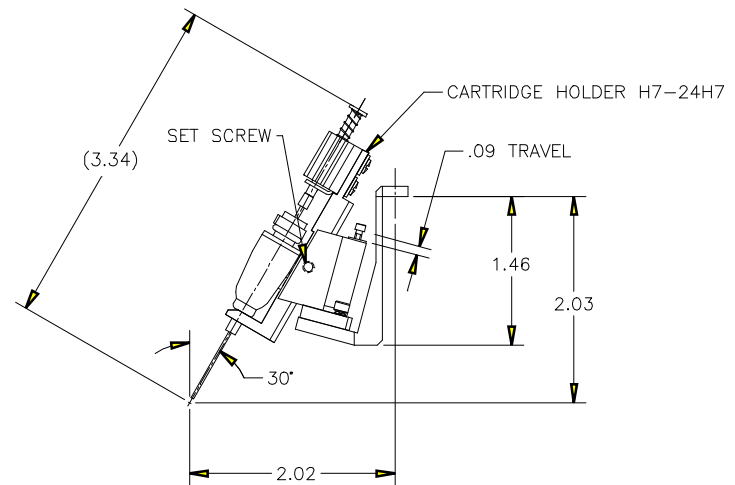
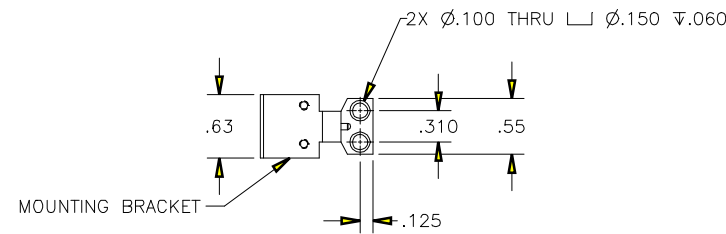

		TITLE		INKER MODEL 403	
1125 N. McDOWELL BLVD. PETALUMA, CA 95954 (707) 763 7799		FILE NAME	9000102B	DO NOT SCALE DRAWING	
SIZE	A	SCALE	1/1	SHEET	2 OF 2
DRAWING NUMBER	900-0102	REV	B		