

©Copyright Xandex Inc., All Rights Reserved.
 The information disclosed herein is deemed to be confidential, proprietary, and a trade secret of Xandex, Inc. This information may not be used, reproduced or disclosed without the express prior written consent of Xandex, Inc.

REVISIONS

| REV | DESCRIPTION | CHANGE NUMBER | BY | DATE | APPROVED |
|-----|----------------|---------------|-----|---------|----------|
| B | REDRAW ON ACAD | 1590 | JMc | 12/2/97 | |

NOTES:

1. FOR USE WITH ALL PACIFIC WESTERN SYSTEMS PROBER MODELS HIGH-SPEED OFF-LINE INKING APPLICATIONS.
2. MOUNTING PLATE IS CONNECTED TO PROBER INSERT RING USING TWO #4-40 X 5/16 FLAT HD. SCREWS (SUPPLIED).
3. THIS INKER USES THE DM-1 CARTRIDGE ONLY.
4. THE MOUNTING ARM IS ADJUSTABLE ALONG THE 'Z' AXIS BY ±.187.
5. THE JOY STICK PROVIDES 'X' AND 'Y' AXIS MOVEMENT AT THE TIP OF THE CARTRIDGE NEEDLE.
6. ALL DIMENSIONS SHOWN WITH ADJUSTMENTS IN NEUTRAL POSITION. A SECOND SET OF HOLES IS PROVIDED FOR THE THUMB SCREW AND JOY STICK, TO ALLOW THE BODY TO BE REPOSITIONED .250 AFT.

| | | | | | |
|-----------|----------|---|----------------|---|----------------|
| FILE NAME | 9000108B | ITEM | QTY | PART NUMBER | DESCRIPTION |
| APPROVALS | DATE | INTERPRET DRAWING PER ANSI Y14.5 - 1982 | | | |
| DRAWN | JMc | 12/2/97 | | | |
| CHECKED | | TOLERANCES UNLESS OTHERWISE SPECIFIED | | | |
| ALL | | DIMENSIONS ARE IN INCHES DECIMALS | | | |
| ENGR | | NEXT ASSEMBLIES.....USED ON | | | |
| DWG | | 1 PL± | FRACTIONS± | TITLE INKER MODEL PWS 602 (KIT #330-2602) | |
| ENGR | | 2 PL± | ANGLES± | DO NOT SCALE DRAWING | |
| | | 3 PL± | ✓ ALL SURFACES | SIZE | SCALE |
| | | 4 PL± | | A | 1/1 |
| | | | | SHEET | DRAWING NUMBER |
| | | | | 1 of 2 | 900-0108 |
| | | | | REV | B |

XANDEX INC.
 1125 N. McDOWELL BLVD.
 PETALUMA, CA 94954
 (707) 763 7799

©Copyright Xandex Inc., All Rights Reserved.
 The information disclosed herein is deemed to be confidential, proprietary, and a trade secret of Xandex, Inc. This information may not be used, reproduced or disclosed without the express prior written consent of Xandex, Inc.

REVISIONS

| REV | DESCRIPTION | CHANGE NUMBER | BY | DATE | APPROVED |
|-----|-------------|---------------|----|------|----------|
| - | SEE SHEET 1 | | | | |

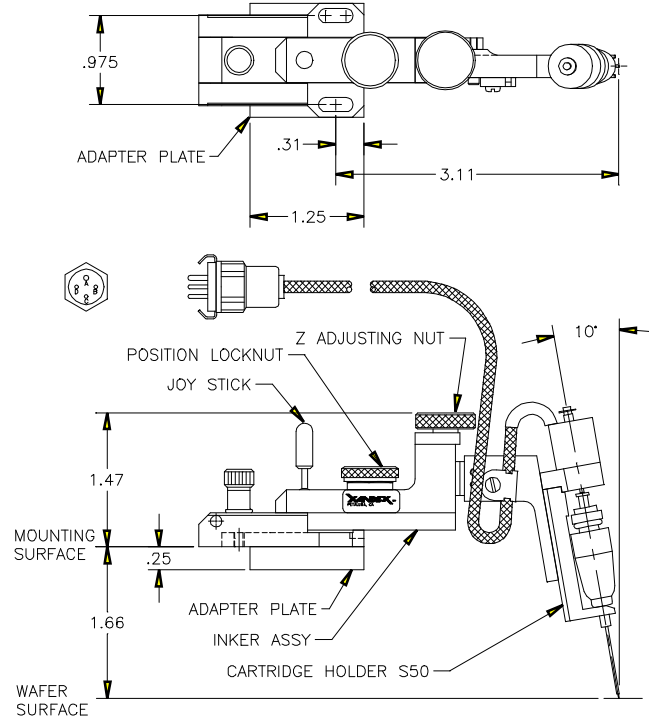

XANDEX INC.

1125 N. McDOWELL BLVD.
 PETALUMA, CA 94954
 (707) 763 7799

| | | | | | |
|---|----------|----------------------|----------|-------|--------|
| TITLE INKER MODEL PWS 602 (KIT #330-2602) | | | | | |
| FILE NAME | 9000108B | DO NOT SCALE DRAWING | | | |
| SIZE | A | SCALE | 1/1 | SHEET | 2 of 2 |
| | | DRAWING NUMBER | 900-0108 | REV | B |