

REVISIONS					
REV	DESCRIPTION	CHANGE NUMBER	BY	DATE	APPROVED
C	REDRAWN ON CADD	495	DT	7/1/91	DT
D	ADD SHEET 1 & NOTE 8	1589	JMc	12/2/97	

**NOTES:**

- FOR USE WITH TERADYNE A500 SERIES, ALL KLA OR TEL PROBERS OVERHEAD TEST APPLICATION.
- MOUNTING PLATE IS CONNECTED TO INTERFACE USING TWO 2-56 X 1/4 LG PAN HD SLOT SCREWS.
- HEX KEY WRENCHES ARE SUPPLIED WITH THIS UNIT.
- THIS INKER USES THE DM-1 AND DM-1.25 CARTRIDGES ONLY.
- ALL DIMENSIONS SHOWN WITH ADJUSTMENTS IN NEUTRAL POSITION.
- HOLDER ALLOWS ADJUSTMENT OF "Z" AXIS BY MOVING IN SLIDE BRACKET.
- COMPONENTS MAY BE ORDERED SEPARATELY: INKER BASE B400 (#320-0400) AND CARTRIDGE HOLDER H7-24E7 (#310-7252).
- FOR 5 MIL CARTRIDGES, RETROFIT CARTRIDGE HOLDER USING PLUNGER STOP ASSEMBLY #210-0016.

FILE NAME 9000124D	ITEM	QTY	PART NUMBER	DESCRIPTION
APPROVALS	DATE	INTERPRET DRAWING PER ANSI Y14.5 - 1982		
DRAWN DAVE T.	6/30/91	1125 N. McDOWELL BLVD. PETALUMA, CA 94954 (707) 763 7799		
CHECKED		TOLERANCES UNLESS OTHERWISE SPECIFIED		
ENGRG DAVE T.	7/1/91	DIMENSIONS ARE IN INCHES		
ENGRG		DECIMALS		
NEXT ASSEMBLIES.....USED ON		1 PL ± FRACTIONS ±		
		2 PL ±.010 ANGLES ±1°		
		3 PL ±.005 63° ALL SURFACES		
		4 PL ±		
DO NOT SCALE DRAWING				
SIZE	SCALE	SHEET	DRAWING NUMBER	REV
A	1/1	1 OF 2	900-0124	D

REVISIONS					
REV	DESCRIPTION	CHANGE NUMBER	BY	DATE	APPROVED
	-SEE SHEET 1-				

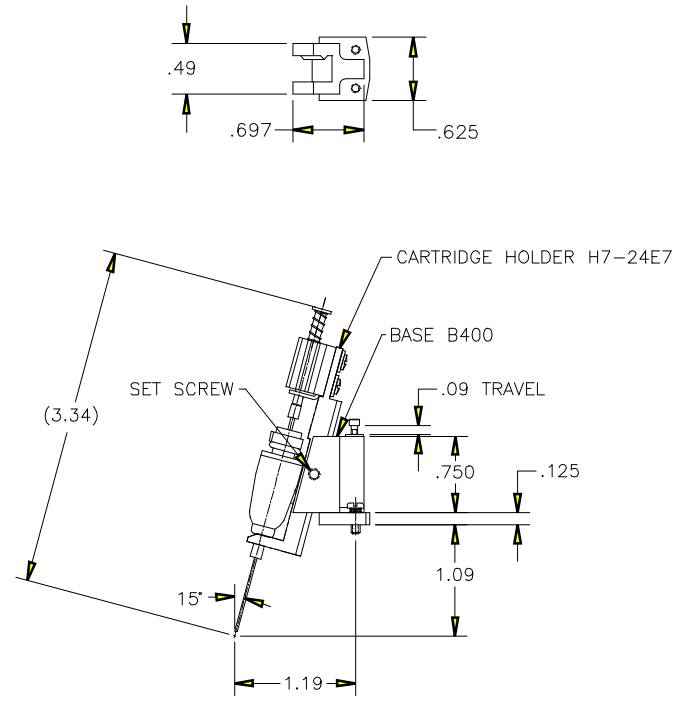

		TITLE INKER MODEL TERADYNE T400 (KIT #330-9400)			
		FILE NAME	9000124D	DO NOT SCALE DRAWING	
SIZE	SCALE	SHEET	DRAWING NUMBER	REV	
A	1/1	2 OF 2	900-0124	D	