

©Copyright Xandex Inc., All Rights Reserved.  
 The information disclosed herein is deemed to be confidential, proprietary, and a trade secret of Xandex, Inc. This information may not be used, reproduced or disclosed without the express prior written consent of Xandex, Inc.

REVISIONS

REV	DESCRIPTION	CHANGE NUMBER	BY	DATE	APPROVED
A	INITIAL RELEASE		JT	2/28/92	DT
B	REVISED PER REDESIGN	564	JT	3/18/93	JCA
C	DEL CABLE, UPDATE FORMAT	1711	JMc	09/08/98	DT

NOTES:

1. INKER IS DESIGNED FOR USE ON TRILLIUM MICROMASTER AND DELTA-MASTER TEST HEADS. TEST HEAD MUST BE OUTFITTED WITH THE BLACK PLASTIC GUARD (TRILLIUM PART NUMBER A-530419-01).
2. FOR 1" POGO STACKS, ORDER INKER KIT EG3100 (PART NUMBER 331-3100). FOR 1.5" POGO STACKS, ORDER INKER KIT EG3110 (PART NUMBER 331-3110). FOR KLA VERSIONS USING 1.5" POGO STACKS, ORDER INKER KIT KLA3200 (PART NUMBER 331-3200). INKERS CAN BE ADAPTED TO 1" OR 1.5" POGO STACKS BY CHANGING THE CARTRIDGE HOLDER MOUNTING ARMS. FOR CONVERSION FROM 1" TO 1.5", ORDER ARM 120-0007. FOR CONVERSION FROM 1.5" TO 1", ORDER ARM 120-0005.
3. X, Y ADJUSTMENT IS ±.062. Z ADJUSTMENT CAPABILITY IS ±.125 PLUS AN ADDITIONAL .10 ADJUSTMENT TO ACCOMODATE PROBE TIPS LONGER THAN .080.
4. INKER CAN BE USED WITH EITHER:  
 THE OLYMPUS SZ SERIES MICROSCOPE WITH A 0.3X OR 0.4X OBJECTIVE LENS. MINIMUM WORKING DISTANCE IS 210mm (8.27").  
 OR:  
 THE OPTEM HF-65 MICROSCOPE WITH A 0.7X-4.5X OBJECTIVE LENS. MINIMUM WORKING DISTANCE IS 90mm (3.50").

FILE NAME 9000139C	ITEM	QTY	PART NUMBER	DESCRIPTION
APPROVALS	DATE	INTERPRET DRAWING PER ASME Y14.5M-1994		 1125 N. McDOWELL BLVD. PETALUMA, CA 94954 (707) 763 7799
DRAWN JMc	8/26/98	TOLERANCES UNLESS OTHERWISE SPECIFIED		
CHECKED MICE D	9/9/98	DIMENSIONS ARE IN INCHES DECIMALS		
ENGR JMc	10/12/98	1 PL± FRACTIONS± 2 PL±.010 ANGLES±1° 3 PL±.005 4 PL±		
ENG'S NEXT ASSEMBLIES.....USED ON	10/9/98	63/ ALL SURFACES		INKER SERIES 3000 REMOTE ADJUST ELECTRIC
				DO NOT SCALE DRAWING
SIZE	SCALE	SHEET	DRAWING NUMBER	REV
A	1/1	1 OF 2	900-0139	C

©Copyright Xandex Inc., All Rights Reserved.  
 The information disclosed herein is deemed to be confidential, proprietary, and a trade secret of Xandex, Inc. This information may not be used, reproduced or disclosed without the express prior written consent of Xandex, Inc.

## REVISIONS

REV	DESCRIPTION	CHANGE NUMBER	BY	DATE	APPROVED
	SEE SHEET 1				

X, Y, Z MANIPULATORS

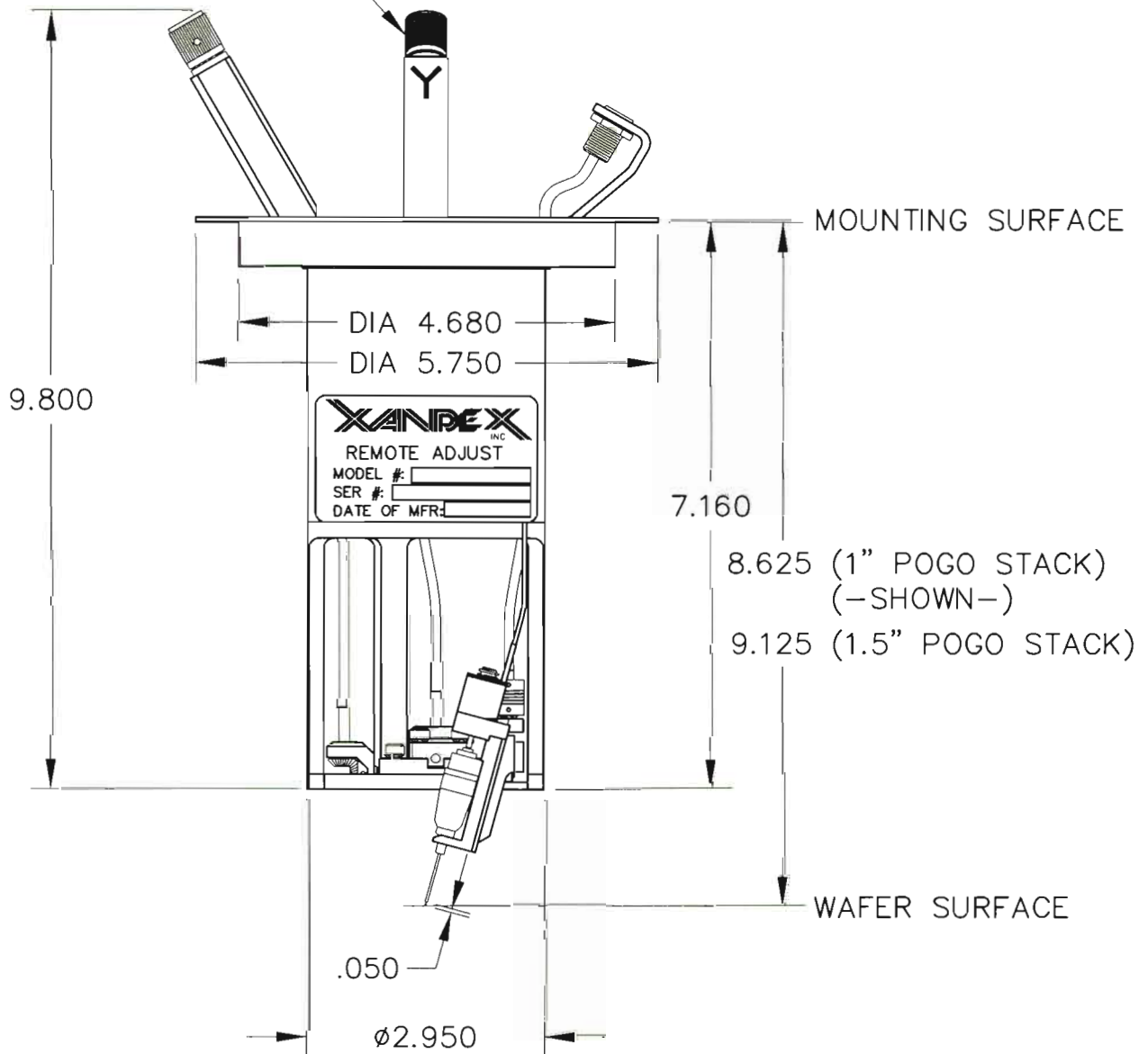

1125 N. McDOWELL BLVD.  
 PETALUMA, CA 94954  
 (707) 763 7799

TITLE  
 INKER SERIES 3000  
 REMOTE ADJUST ELECTRIC

FILE NAME 9000139C		DO NOT SCALE DRAWING		
SIZE A	SCALE 1/1	SHEET 2 OF 2	DRAWING NUMBER 900-0139	REV C