

REVISIONS					
REV	DESCRIPTION	CHANGE NUMBER	BY	DATE	APPROVED
A	INITIAL RELEASE	609	KM	5/20/93	DT
B	DEL CABLE, UPDATE FORMAT	1711	JMc	09/08/98	

**NOTES:**

1. INKER IS DESIGNED FOR USE ON LTX HT AND HI-T TEST HEADS. TEST HEAD MUST BE RETRO-FITTED WITH THE XANDEX DELRIN SPACER PART NUMBER 120-0059, REPLACING THE EXISTING LTX SPACER, PART NUMBER 851-6914-00.
2. X, Y ADJUSTMENT IS  $\pm 0.062$ . Z ADJUSTMENT CAPABILITY IS  $\pm 0.125$  PLUS AN ADDITIONAL ABILITY TO ADJUST THE CARTRIDGE HOLDER TO ACCOMMODATE PROBE TIPS LONGER THAN .080.
3. INKER IS DESIGNED FOR USE WITH THE OPTEM HF-65 MICROSCOPE WITH A 0.7X-4.5X OBJECTIVE LENS. MINIMUM WORKING DISTANCE IS 90mm (3.50").
4. ORDER INKER KIT EG3301 (PART NUMBER 331-3301).

FILE NAME 9000153B	ITEM	QTY	PART NUMBER	DESCRIPTION
APPROVALS KM	DATE 5/18/93	INTERPRET DRAWING PER ASME Y14.5M-1994		 1125 N. McDOWELL BLVD. PETALUMA, CA 94954 (707) 763 7799
TOLERANCES UNLESS OTHERWISE SPECIFIED		DIMENSIONS ARE IN INCHES DECIMALS		
NEXT ASSEMBLIES.....USED ON		1 PL±	FRACTIONS±	<b>INKER SERIES 3301, LTX-HT          REMOTE ADJUST ELECTRIC</b>  DO NOT SCALE DRAWING
		2 PL±.010	ANGLES±1°	
		3 PL±.005	63/ ALL SURFACES	
		4 PL±		
SIZE	SCALE	SHEET	DRAWING NUMBER	REV
A	1/1	1 of 2	900-0153	B

REVISIONS					
REV	DESCRIPTION	CHANGE NUMBER	BY	DATE	APPROVED
	SEE SHEET 1				

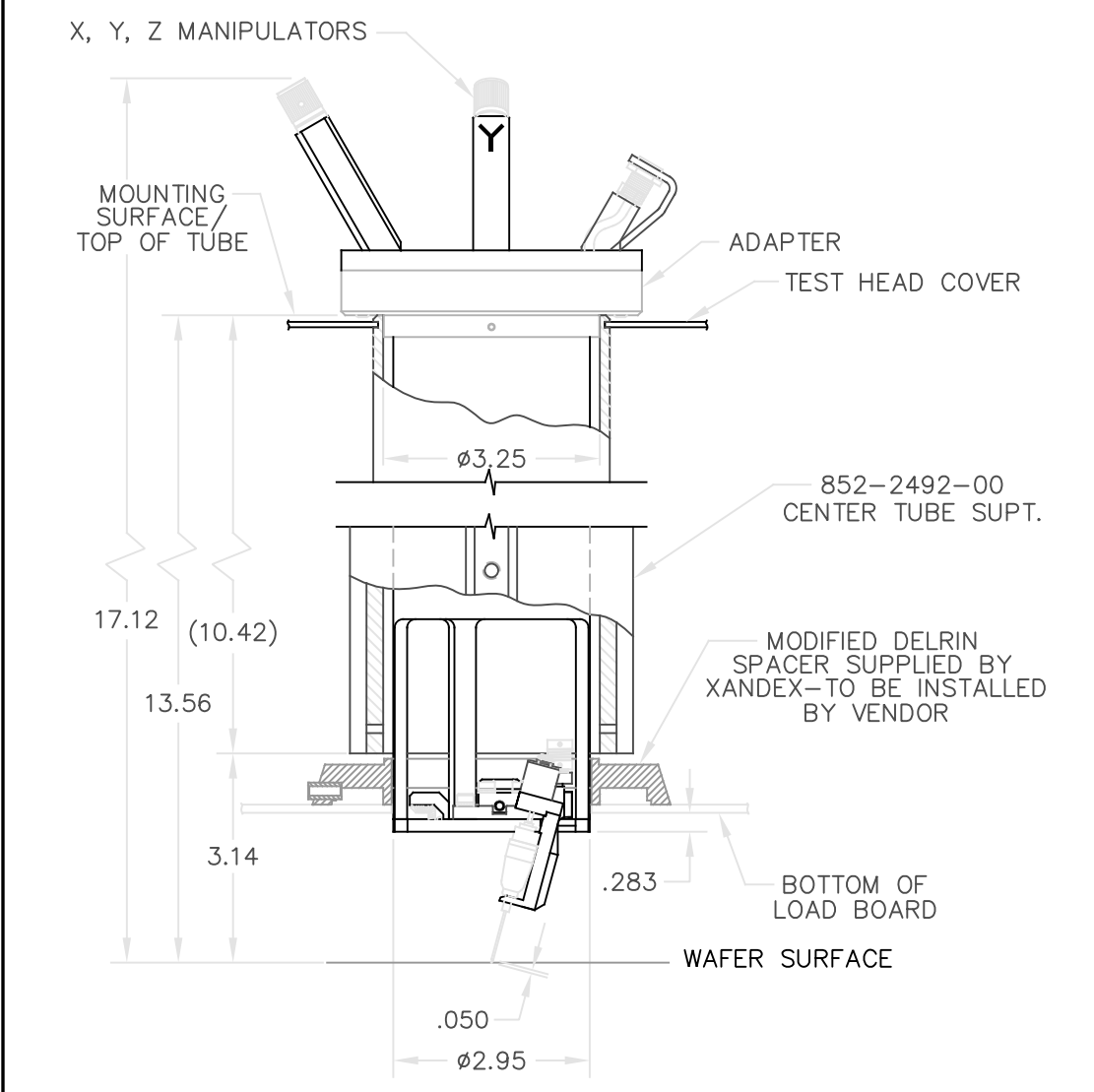

 1125 N. McDOWELL BLVD. PETALUMA, CA 94954 (707) 763 7799		<b>INKER SERIES 3301, LTX-HT          REMOTE ADJUST ELECTRIC</b>  DO NOT SCALE DRAWING			
FILE NAME	9000153B	DO NOT SCALE DRAWING			
SIZE	SCALE	SHEET	DRAWING NUMBER	REV	
A	1/1	2 of 2	900-0153	B	