

© Copyright Xandex Inc., All Rights Reserved.  
 The information disclosed herein is deemed to be confidential, proprietary, and a trade secret of Xandex, Inc. This information may not be used, reproduced or disclosed without the express prior written consent of Xandex, Inc.

## REVISIONS

REV	DESCRIPTION	CHANGE NUMBER	BY	DATE	APPROVED
C	UPDATE TITLE BLOCK	4366	MRW	12/04/17	<i>JB</i>

NOTES:

1. REMOVE EXISTING Y380 INKER PARTS MOUNTED TO DOVETAIL BRACKET TO ALLOW INSTALLATION OF THE XANDEX HOLDER ASSEMBLY.
2. HOLDER ASSEMBLY IS MOUNTED TO EXISTING Y380 INKER AS SHOWN USING (2) 1-64 X 3/8 SCREWS.
3. ADAPTER ASSEMBLY USES DM-1 CARTRIDGES.
4. ORDER PART NUMBER 315-0008, S3-12C10.

APPROVALS	DATE	ITEM	QTY	PART NUMBER	DESCRIPTION										
DRAWN D. TEGLIA	06/05/95			INTERPRET DRAWING PER ASME Y14.5M-1994	1360 REDWOOD WAY, SUITE A PETALUMA, CA 94954 (707) 763 7799										
CHECKED <i>[Signature]</i>	12/7/17			TOLERANCES UNLESS OTHERWISE SPECIFIED											
ENGRG D. TEGLIA	10/09/98			DIMENSIONS ARE IN INCHES DECIMALS											
NEXT ASSEMBLIES.....USED ON				1 PL±      FRACTIONS± 2 PL±.01      ANGLES±1° 3 PL±.005 4 PL±      63/100 √ ALL SURFACES	TITLE HOLDER ASSEMBLY S3 (Y380: TSP-30 SOLENOID)										
DO NOT SCALE DRAWING					<table border="1" style="width: 100%; border-collapse: collapse;"> <tr> <th style="width: 10%;">SIZE</th> <th style="width: 10%;">SCALE</th> <th style="width: 10%;">SHEET</th> <th style="width: 30%;">DRAWING NUMBER</th> <th style="width: 10%;">REV</th> </tr> <tr> <td style="text-align: center;">A</td> <td style="text-align: center;">1/1</td> <td style="text-align: center;">1 OF 2</td> <td style="text-align: center;">900-0164</td> <td style="text-align: center;">C</td> </tr> </table>	SIZE	SCALE	SHEET	DRAWING NUMBER	REV	A	1/1	1 OF 2	900-0164	C
SIZE	SCALE	SHEET	DRAWING NUMBER	REV											
A	1/1	1 OF 2	900-0164	C											

© Copyright Xandex Inc., All Rights Reserved.  
 The information disclosed herein is deemed to be confidential, proprietary, and a trade secret of Xandex, Inc. This information may not be used, reproduced or disclosed without the express prior written consent of Xandex, Inc.

REVISIONS

REV	DESCRIPTION	CHANGE NUMBER	BY	DATE	APPROVED
	SEE SHEET 1				

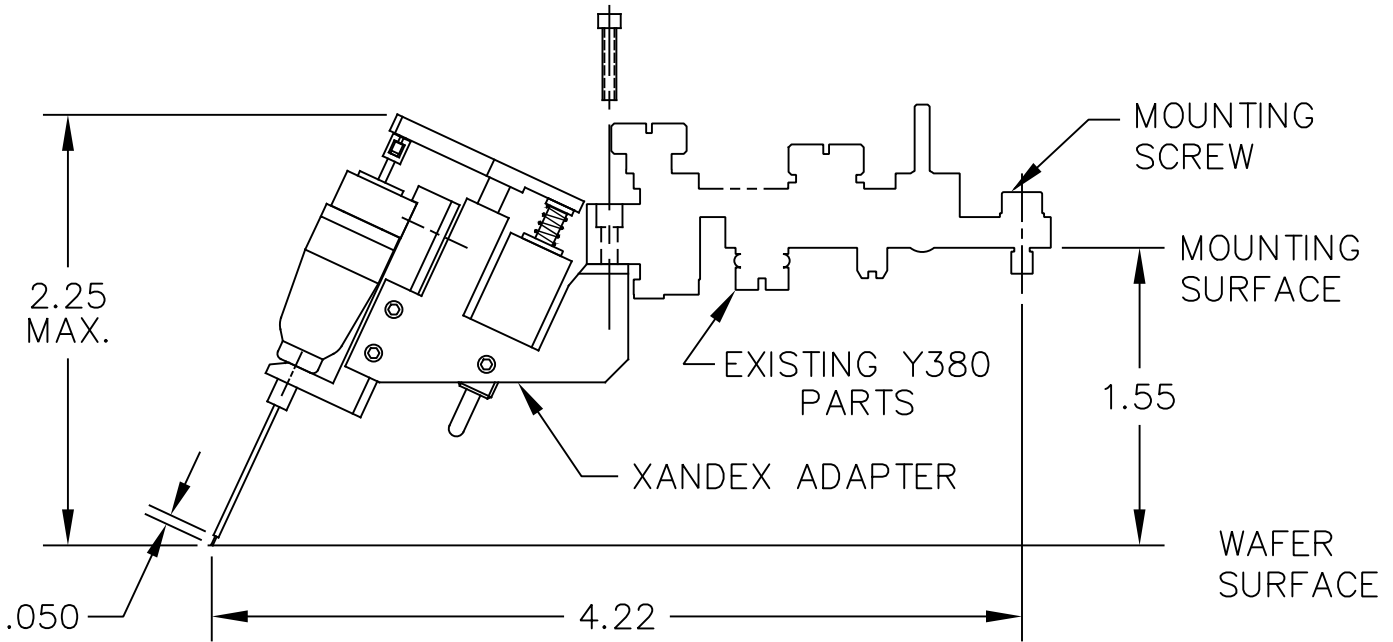
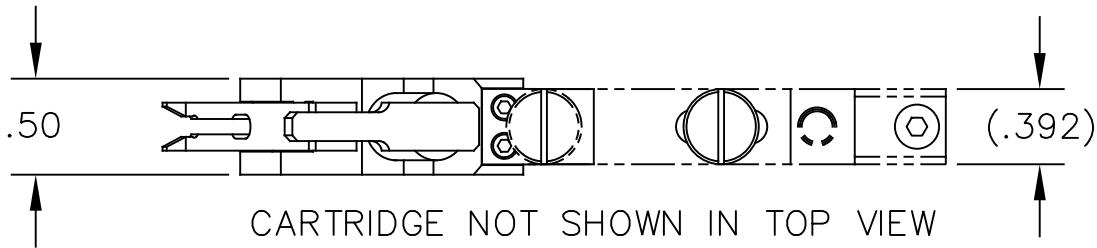

1360 REDWOOD WAY, SUITE A  
 PETALUMA, CA 94954  
 (707) 763 7799

TITLE HOLDER ASSEMBLY S3  
 (Y380: TSP-30 SOLENOID)

SEE SHEET 1 FOR NOTES AND TOLERANCE INFORMATION

DO NOT SCALE DRAWING

SIZE	SCALE	SHEET
A	1/1	2 OF 2

DRAWING NUMBER
900-0164

REV
C