

©Copyright 1995, Xandex Inc., All Rights Reserved.
 The information disclosed herein is deemed to be confidential, proprietary, and a trade secret of Xandex, Inc. This information may not be used, reproduced or disclosed without the express prior written consent of Xandex, Inc.

REVISIONS					
REV	DESCRIPTION	CHANGE NUMBER	BY	DATE	APPROVED
A	INITIAL RELEASE	0328	JMc	06/25/97	DT
B	REV TO MAG BASE	1801	RAP	04/30/99	

NOTES:

1. INKER FOR EG PROBER, OFF LINE OR CABLED PROBING.
2. THIS INKER REQUIRES THE USE OF DM-2.3 CARTRIDGES WHEN USED IN LINE ON A 4080 OR 4090 SERIES PROBER (AS SHOWN ON SHEET 2).
3. INKER ARM IS ADJUSTABLE ALONG THE "Z" AXIS BY $\pm .188$.
4. JOYSTICK PROVIDES "X" AND "Y" AXIS MOVEMENT AT THE TIP OF THE CARTRIDGE NEEDLE.
5. ALL DIMENSIONS SHOWN WITH ADJUSTMENTS IN NEUTRAL POSITION.
6. INKER MOUNTS TO THE PROBER USING TWO M3 X .5 X 6MM PAN HEAD SLOTTED SCREWS (SUPPLIED).

FILE NAME	9000193B	ITEM	QTY	PART NUMBER	DESCRIPTION
APPROVALS	DATE	INTERPRET DRAWING			1125 N. McDOWELL BLVD. PETALUMA, CA 95954 (707) 763 7799
DRAWN	JMc	6/25/97	PER ANSI Y14.5 - 1982		
CHECKED			TOLERANCES		
DATE			UNLESS OTHERWISE SPECIFIED	TITLE	PNEUMATIC INKER, X1103
ENGRG	D. TEGLIA	07/09/97	DIMENSIONS ARE IN INCHES		(KIT #340-1103)
UPG			DECIMALS	DO NOT SCALE DRAWING	
ENGRG			1 PL \pm FRACTIONS \pm	SIZE	A
NEXT ASSEMBLIES.....USED ON			2 PL \pm ANGLES \pm	SCALE	1/1
			3 PL \pm	SHEET	1 of 2
			4 PL \pm <input checked="" type="checkbox"/> ALL SURFACES	DRAWING NUMBER	900-0193
				REV	B

©Copyright 1995, Xandex Inc., All Rights Reserved.
 The information disclosed herein is deemed to be confidential, proprietary, and a trade secret of Xandex, Inc. This information may not be used, reproduced or disclosed without the express prior written consent of Xandex, Inc.

REVISIONS					
REV	DESCRIPTION	CHANGE NUMBER	BY	DATE	APPROVED
-	SEE SHEET 1	-	-	-	-

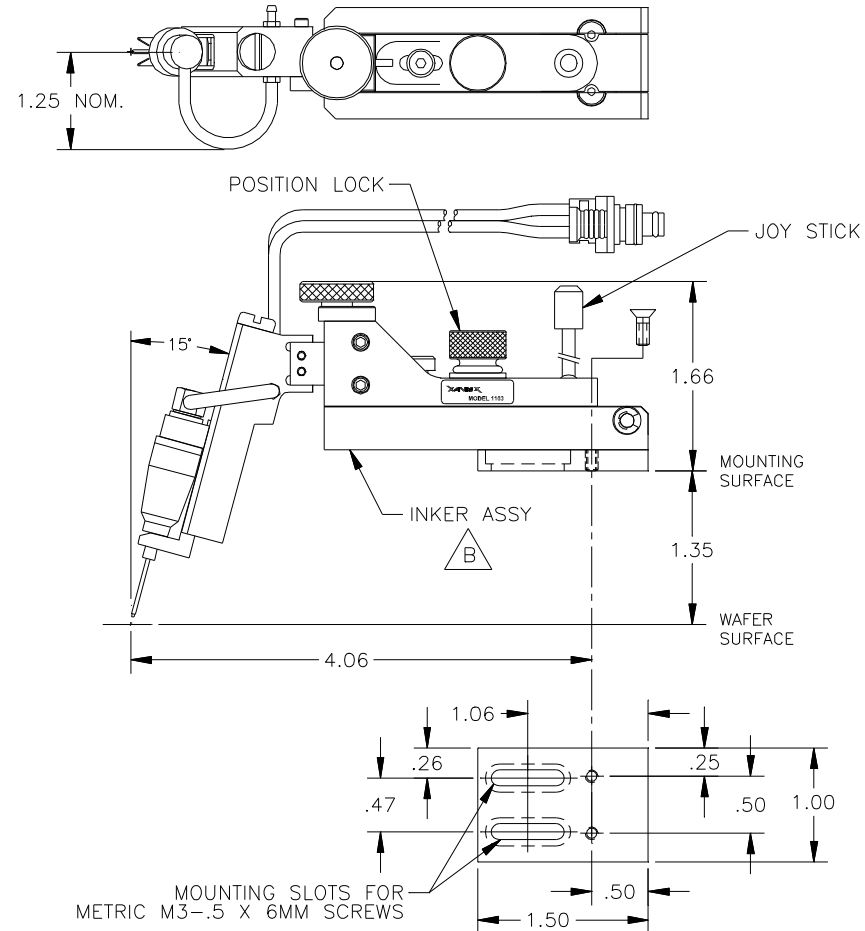

XANDEX
 INC.
 1125 N. McDOWELL BLVD.
 PETALUMA, CA 95954
 (707) 763 7799

TITLE		PNEUMATIC INKER, X1103			
		(KIT #340-1103)			
FILE NAME	9000193B	DO NOT SCALE DRAWING			
SIZE	A	SCALE	1/1	SHEET	2 of 2
		DRAWING NUMBER	900-0193	REV	B