

©Copyright Xandex Inc., All Rights Reserved.
The information disclosed herein is deemed to be confidential, proprietary, and a trade secret of Xandex, Inc. This information may not be used, reproduced or disclosed without the express prior written consent of Xandex, Inc.

REVISIONS

REV	DESCRIPTION	CHANGE NUMBER	BY	DATE	APPROVED
A	INITIAL RELEASE	0390	JMG	04/06/99	

NOTES:

1. INKER IS DESIGNED FOR USE ON SENTRY 7 TESTERS.
2. INKER ADAPTER MOUNTS TO THE TEST HEAD USING (4) 6-32 X 3/4 LONG SOCKET HEAD CAP SCREWS.
3. X, Y ADJUSTMENT IS ±.062. Z ADJUSTMENT CAPABILITY IS ±.125 PLUS AN ADDITIONAL .10 ADJUSTMENT TO ACCOMODATE PROBE TIPS LONGER THAN .080.
4. INKER CAN BE USED WITH: THE OPTEM HF-65 MICROSCOPE WITH A 0.7X-4.5X OBJECTIVE LENS. MINIMUM WORKING DISTANCE IS 90mm (3.50").
5. ORDER INKER KIT EG3312 (PART No. 331-3312).

APPROVALS	DATE	ITEM	QTY	PART NUMBER	DESCRIPTION			
DRAWN JAMES G.	04/06/99	INTERPRET DRAWING PER ASME Y14.5M-1994			1125 N. McDOWELL BLVD. PETALUMA, CA 94954 (707) 763 7799			
CHECKED		TOLERANCES UNLESS OTHERWISE SPECIFIED DIMENSIONS ARE IN INCHES						
G.C.		DECIMALS		TITLE INKER, EG3312, SENTRY 7, R/A, ELECTRIC				
ENGRG		FRACTIONS ±		DO NOT SCALE DRAWING				
MFG ENGRG		ANGLES ±1°		SIZE SCALE SHEET DRAWING NUMBER REV				
NEXT ASSEMBLIES.....USED ON		1 PL ±		A	1/2	1 of 2	900-3312	A
		2 PL ±.010						
		3 PL ±.005						
		4 PL ±	63/√ ALL SURFACES					

©Copyright Xandex Inc., All Rights Reserved.
The information disclosed herein is deemed to be confidential, proprietary, and a trade secret of Xandex, Inc. This information may not be used, reproduced or disclosed without the express prior written consent of Xandex, Inc.

REVISIONS

REV	DESCRIPTION	CHANGE NUMBER	BY	DATE	APPROVED
-	SEE SHEET 1				

X, Y, Z MANIPULATORS

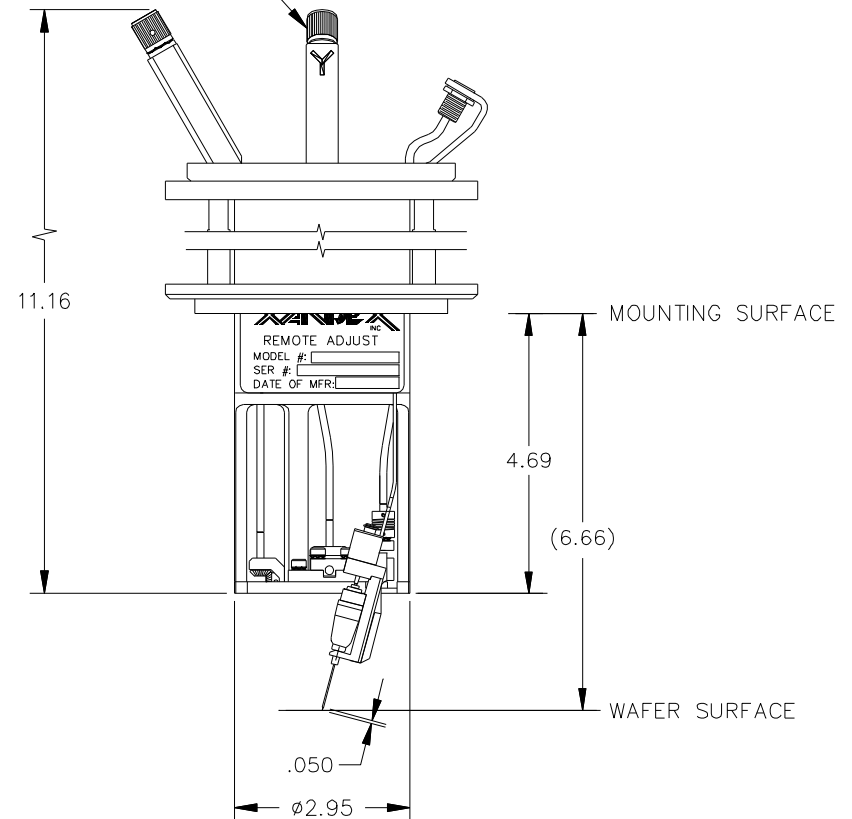

		TITLE INKER, EG3312, SENTRY 7, R/A ELECTRIC	
1125 N. McDOWELL BLVD. PETALUMA, CA 94954 (707) 763 7799		DO NOT SCALE DRAWING	
FILE NAME		DRAWING NUMBER	REV
SIZE	SCALE	SHEET	
A	1/2	2 of 2	A
		900-3312	