

©Copyright Xandex Inc., All Rights Reserved.
 The information disclosed herein is deemed to be confidential, proprietary, and a trade secret of Xandex, Inc. This information may not be used, reproduced or disclosed without the express prior written consent of Xandex, Inc.

REVISIONS

REV	DESCRIPTION	CHANGE NUMBER	BY	DATE	APPROVED
A	INITIAL RELEASE	0396	DT	06/25/99	

NOTES:

1. INKER IS DESIGNED FOR USE ON HP4062 TESTERS.
2. INKER ADAPTER MOUNTS TO THE TEST HEAD USING (3) 4-40 X 1/2 LONG SOCKET HEAD CAP SCREWS.
3. X, Y ADJUSTMENT IS ±.062. Z ADJUSTMENT CAPABILITY IS ±.125 PLUS AN ADDITIONAL .10 ADJUSTMENT TO ACCOMODATE PROBE TIPS LONGER THAN .080.
4. INKER CAN BE USED WITH: THE OPTEM HF-165 MICROSCOPE WITH A 0.7X-4.5X OBJECTIVE LENS. MINIMUM WORKING DISTANCE IS 90mm (3.50").
5. ORDER INKER KIT EG3313 (PART No. 331-3313).

APPROVALS	DATE	ITEM	QTY	PART NUMBER	DESCRIPTION
DRAWN D. TEGLIA	06/25/99	INTERPRET DRAWING PER ASME Y14.5M-1994			 1125 N. McDOWELL BLVD. PETALUMA, CA 94954 (707) 763 7799
CHECKED		TOLERANCES UNLESS OTHERWISE SPECIFIED			
D.C.		DIMENSIONS ARE IN INCHES			TITLE INKER, EG3313, HP4062 R/A, ELECTRIC
ENGRG		DECIMALS			
MFG ENGRG		1 PL ± FRACTIONS ±			DO NOT SCALE DRAWING
NEXT ASSEMBLIES.....USED ON 331-3313		2 PL ±.010 ANGLES ±			
		3 PL ±			SIZE A
		4 PL ± <input checked="" type="checkbox"/> ALL SURFACES			SCALE 1/2
					SHEET 1 of 2
					DRAWING NUMBER 900-3313
					REV A

©Copyright Xandex Inc., All Rights Reserved.
 The information disclosed herein is deemed to be confidential, proprietary, and a trade secret of Xandex, Inc. This information may not be used, reproduced or disclosed without the express prior written consent of Xandex, Inc.

REVISIONS

REV	DESCRIPTION	CHANGE NUMBER	BY	DATE	APPROVED
-	SEE SHEET 1				

X, Y, Z MANIPULATORS

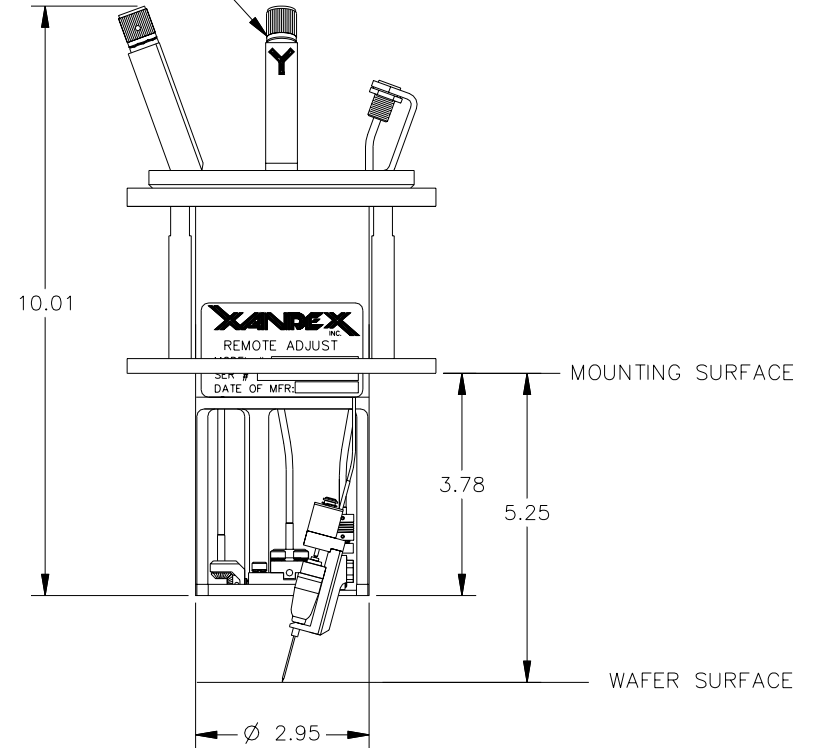

1125 N. McDOWELL BLVD.
 PETALUMA, CA 94954
 (707) 763 7799

TITLE INKER, EG3313, HP4062
 R/A ELECTRIC

FILE NAME	DO NOT SCALE DRAWING				
SIZE	SCALE	SHEET	DRAWING NUMBER	REV	
A	1/2	2 of 2	900-3313	A	