

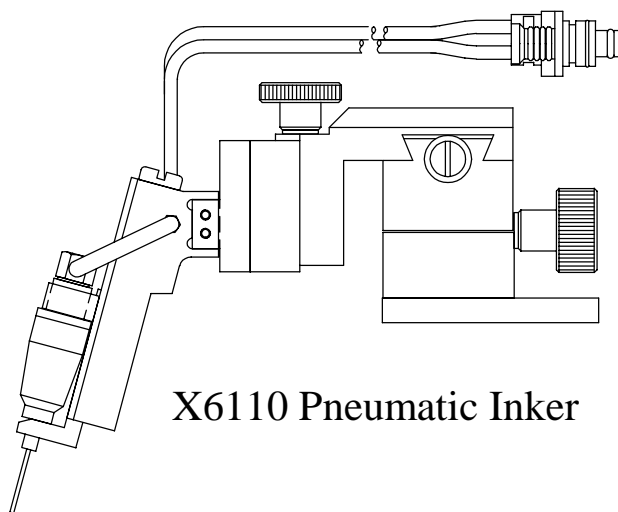

X6110 PNEUMATIC INKER
with MICRO POSITIONER BASE
INSTALLATION AND OPERATION MANUAL



X6110 Pneumatic Inker

OBSOLETE

TABLE OF CONTENTS

SECTION 1. INTRODUCTION.....	1-1
Theory of Operation	1-1
SECTION 2. SYSTEM OVERVIEW.....	2-1
System Components.....	2-1
SECTION 3. INSTALLATION.....	3-1
X6110 Inker Assembly Installation.....	3-1
Controller Installation	3-3
Voltage Selection & Fuse Replacement.....	3-6
SECTION 4. SYSTEM OPERATION.....	4-1
Controller Operation	4-1
<i>Programmable Thumbwheel Counter</i>	4-2
<i>Mode Selection Switch</i>	4-2
<i>Reset Button:</i>	4-2
<i>Dot Counter:</i>	4-2
<i>Adjustable Dot Size</i>	4-3
<i>External Switch Input</i>	4-3
Ink Cartridge.....	4-4
<i>Cartridge Preparation</i>	4-4
<i>Cartridge Installation</i>	4-5
<i>Changing the Cartridge</i>	4-6
<i>Cartridge Priming</i>	4-6
Ink Cartridge Labeling	4-7
<i>DieMark™ Cartridge Type Label</i>	4-7
<i>DieMark™ Cartridge Expiration Date Label</i>	4-7
Inker Assembly Setup & Alignment	4-8
SECTION 5. INK	5-1
General Information	5-1
Ink Curing.....	5-2
Ink Removal	5-3
SECTION 6. MAINTENANCE/TROUBLESHOOTING.....	6-1
Ink Troubleshooting	6-1
Inker Assembly Troubleshooting	6-3
Shuttle Maintenance.....	6-5
Controller Maintenance and Diagnostics	6-8
Controller Troubleshooting.....	6-11
Controller Internal Maintenance	6-12
Controller PM and Valve Replacement	6-14

SECTION 7. SOFTWARE OPTIONS.....	7-1
Optional Software Programs	7-1
SECTION 8. SYSTEM SPECIFICATIONS	8-1
APPENDIX A. INKER WARRANTY	8-3
APPENDIX B. DRAWINGS	8-4

Section 1. Introduction

Theory of Operation

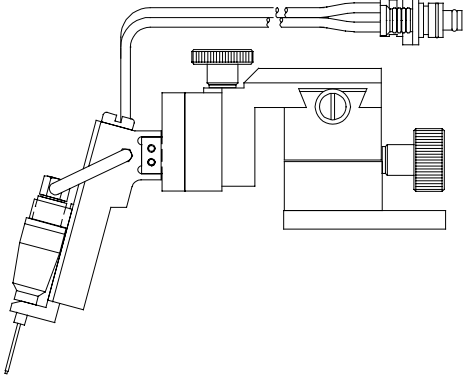

The X6110 Pneumatic Inker incorporates the convenience of DieMark disposable ink cartridges with the reliability of a microprocessor-controlled pneumatic dispensing system for the ultimate inking solution. The unique X6110 micropositioner inker base enables precise adjustment of the cartridge tip in X, Y and Z.

Ink dots are deposited via pneumatic actuation of the inker shuttle mechanism and a simultaneous pulse of air into the cartridge reservoir. There is no filament and no direct contact with the wafer surface. A proper signal to the controller initiates the inking sequence, actuating the shuttle mechanism downward and sending an air pulse to the cartridge.

As the shuttle extends to the downward position, the air pulse to the cartridge forces ink out of the cartridge barrel and forms a drop at the end of the needle tip. When the shuttle is at its lowest position, the drop makes contact with the wafer surface and forms a dot.

After 22.5 milliseconds the shuttle returns to the normal position. After completion of each dot, a small amount of vacuum is developed in the cartridge by the closure of the valve, causing the ink to back up into the cartridge reservoir, preventing dripping.

If another dot sequence is not initiated within 10 seconds, a “puff” pulse of air equal to 1/2 the dot setting duration (10-20 ms) will displace a small amount of ink back into the Teflon® tube to aid in maintaining proper dot size after long delays between dots.

The dot size is determined by cartridge air pulse duration. Adjust the controller setting to change the dot size - without changing the cartridge. Pneumatic cartridges are factory tuned, ensuring consistent dots and contain 40% more ink than standard DieMark cartridges.

Thank you for selecting ...  ...as your inking choice.

Please spend a few minutes familiarizing yourself with the unit. Most questions you may have will be answered in this manual. If you would like further assistance, please contact your local Xandex distributor or call us at (707) 763-7799 or Toll Free in the U.S: (800) 767-9543. FAX (707) 763-2631. For more information about Xandex and our complete line of quality inking and interfacing products, visit us on the Internet at <http://www.xandex.com> or email: us at info@xandex.com.

This page is intentionally left blank.

Section 2. System Overview

System Components / Kit Part No. 340-6110 (X6110)

1. Regulator Assembly
Part No. 160-0032
2. Cable/Connector Assembly
Type AC - Part No. 210-0109
3. Air Hose Regulator > Controller
Part No. 210-2001
4. **A.** AC Power Cord (USA)*
Part No. 158-0051
- B.** AC Power Cord (UK)*
Part No. 158-0408
- C.** AC Power Cord (Europe)*
Part No. 158-0407
5. Pneumatic Controller
(Includes AC Power Cord)
Part No. 350-0002
6. Pneumatic Inker Assembly
Part No. 320-6110 (X6110)
7. Pneumatic Shuttle
Part No. 316-0001
8. Air Hose Shuttle > Cartridge
P/N 210-2002

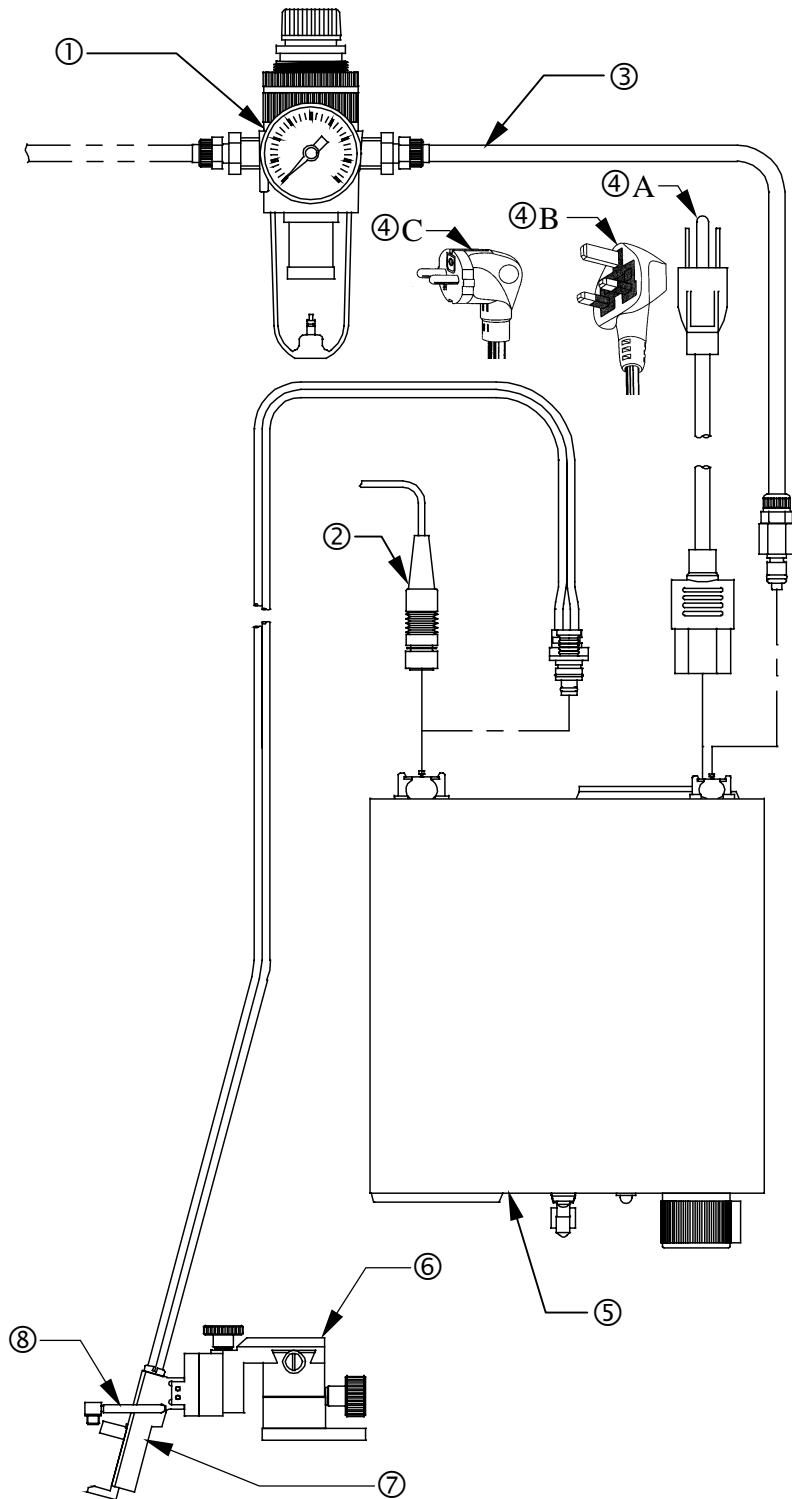

*One (1) Power Cord, specified at time of ordering, is included with each kit.

This page is intentionally left blank.

Section 3. Installation

X6110 Inker Installation

The X6110 pneumatic inker installs directly onto the insert ring on an Electroglas 1034 or 20X0 series prober.



CAUTION: Move the chuck/wafer from underneath the inker when installing inker to prevent damage.

1. Disconnect and remove any inker currently installed on the prober.
2. Raise the shuttle on the inker base to maximum Z height by turning the Z adjustment knob clockwise to the end of travel position.
3. Position the X6110 over the inker mounting holes on the insert ring.
4. Install inker using two (2X) 4-40 x 3/8 socket head screws (P/N 510-3806 supplied) and two (2X) #4 flat washers (P/N 511-0015 supplied) as shown below. Slots in the bottom plate on the inker base allow approximately 0.375" adjustment for inker placement.

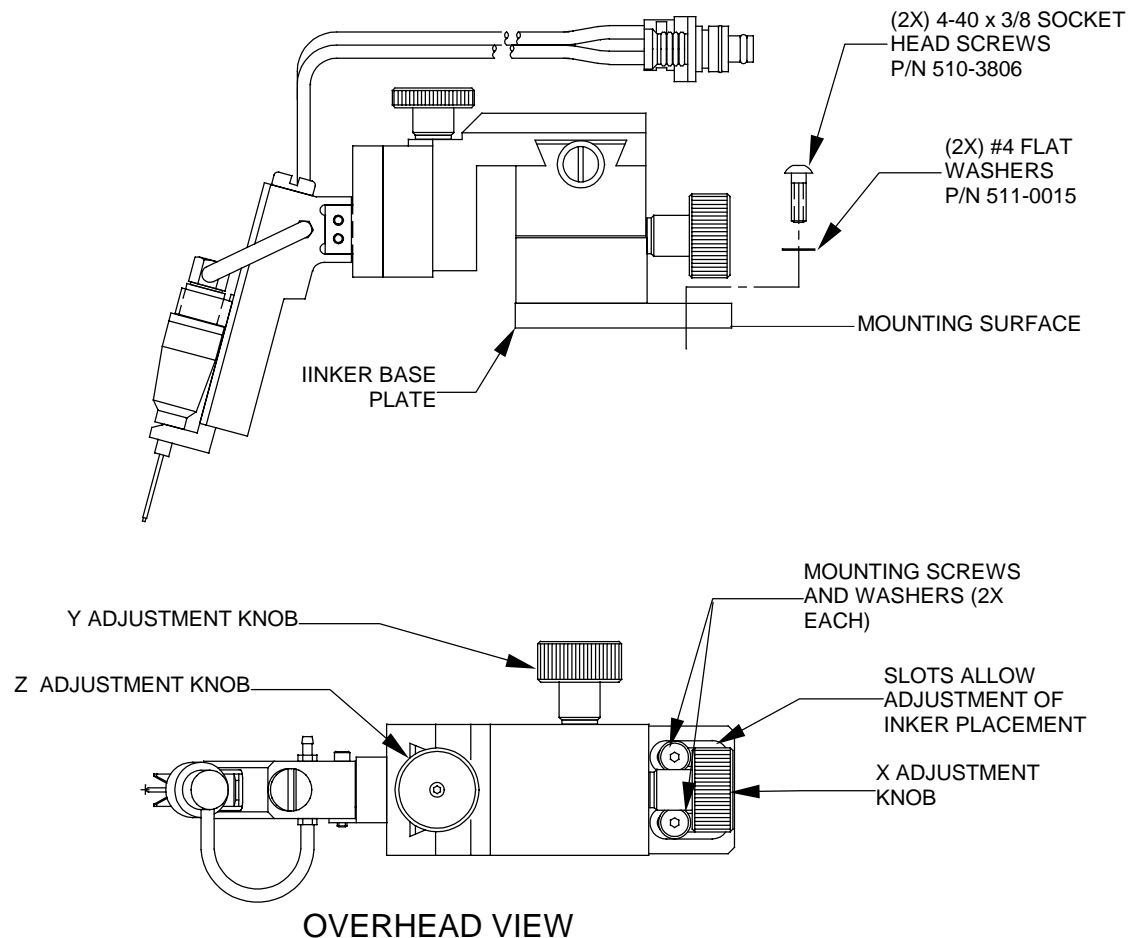

4. Proceed to the “**Controller Installation**” portion of this Installation section (3), and install the pneumatic controller per instructions for your application.
5. With the controller installed, connect the fitting on the *controller-to-shuttle air hose* into the upper left pneumatic connection on the rear of the pneumatic controller.
6. Proceed to **Section 4 “System Operation”** for ink cartridge installation, inker setup, alignment and controller operation instructions.

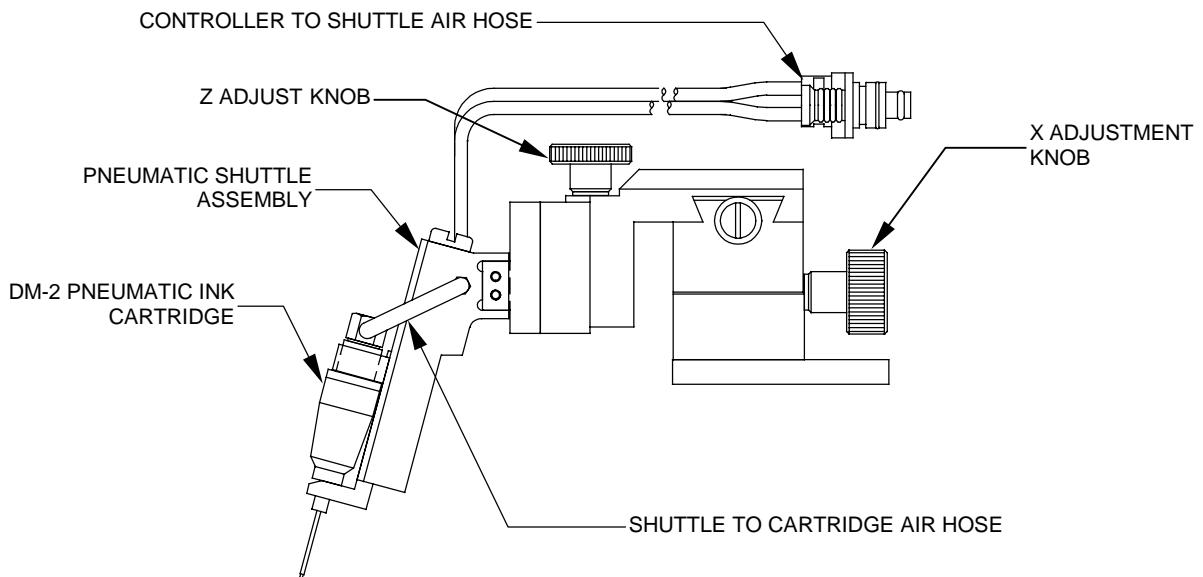

Controller Installation

1. Assemble the regulator/filter by first locating the air flow direction arrow on the front of the regulator and installing the supplied gauge into the hole below the arrow. The gauge side of the regulator will now be referred to as the front of the regulator.

Note: We recommend that either pipe thread sealer or Teflon® tape (not supplied) be used on all pneumatic connections to ensure proper sealing.

2. Install one of the supplied plugs in the hole on the back of the regulator.

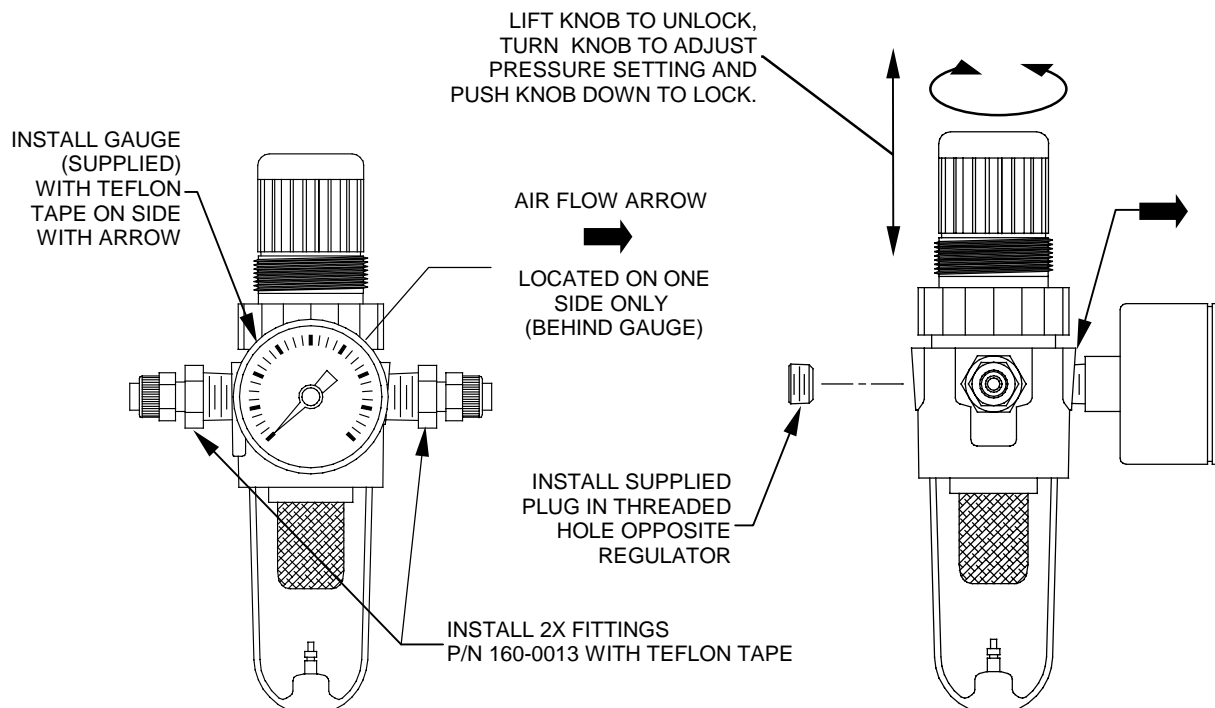

3. Install the two 1/4 O.D. x 1/4 NPT fittings (P/N 160-0013 supplied) into the two remaining threaded holes on the sides of the regulator body (on either side of the gauge).
4. Mount the regulator/filter bracket in a convenient location (mounting screws are not supplied). The regulator can be mounted to the bracket with the supplied nut after completely assembled.

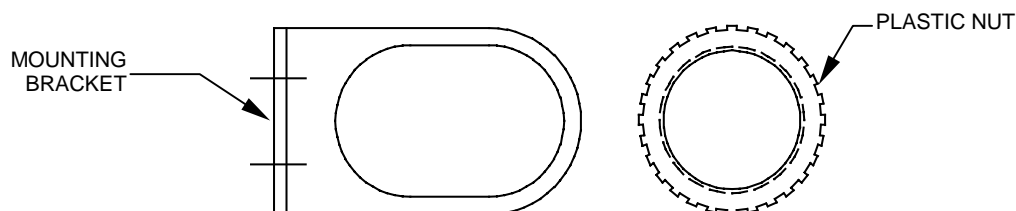

5. Install 1/4 O.D. x 0.170 I.D. polyethylene tubing (not supplied) to the main air source and then connect to the input fitting on the regulator. (The left side when facing the gauge.)
6. Connect the *regulator-to-pneumatic controller air hose* (P/N 210-2001 supplied) to the *output fitting* on the regulator. (The right side when facing the gauge.)

Note: *The regulator-to-pneumatic controller air hose supplied by Xandex, is 6 feet long. If the distance (hose length) requirement exceeds this length, use 1/4 O.D. x 0.170 I.D. polyethylene tubing.*

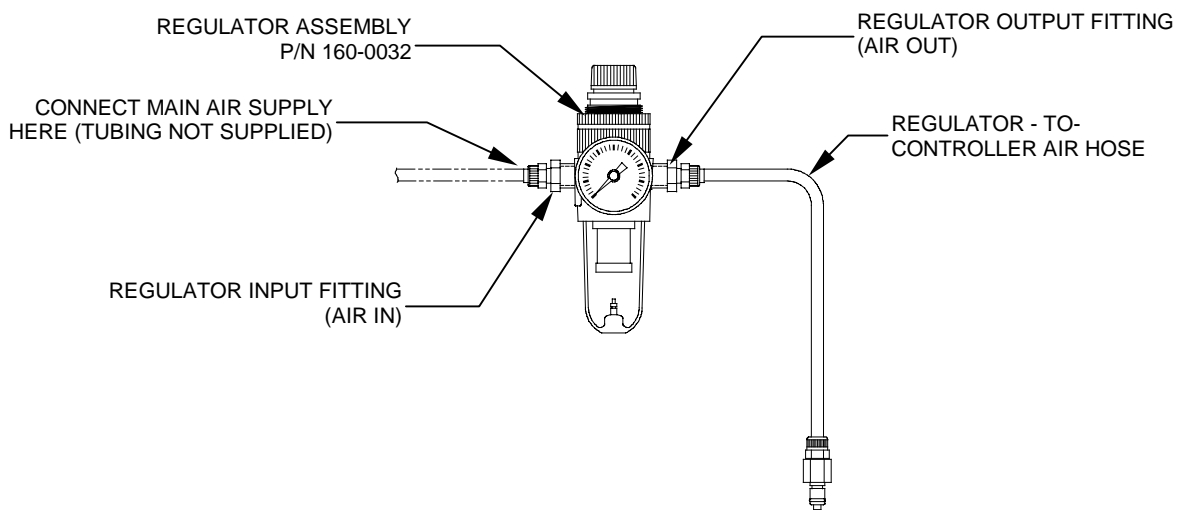

7. Plug the *regulator-to-controller air hose* into the **small** air connection on the rear of controller.

Note: *The air hose connectors are spring locked. If the air hose connectors do not insert easily, make sure the spring lock is in the open position by pushing the metal snap-lock down until it clicks.*

8. Turn on the main air and adjust the regulator until it reads 70 ± 10 PSI on the dial. To make regulator adjustments, pull up on the knob on the top of the regulator to unlock, then rotate the knob clockwise to increase or counter-clockwise to decrease. Push down on the knob after adjustment to lock it into position.
9. Check all connections for air leaks. If required, turn off the main air and make necessary repairs.
10. Install the *cable/connector* (P/N 210-0109) to the inker box on the prober and the "PROBER" connector on the rear of the controller unit.
11. Move the toggle switch on front of the controller to "RUN" (mid) position.

12. The controller is factory set at 120 VAC @ 50-60 Hz. If your AC input voltage is different than 120V, follow the instructions in this Section (3) **“Voltage Selection and Fuse Replacement”** to change the controller to your requirement.
13. Install the *AC power cord* into the back of the controller. Plug the power cord into an AC supply outlet. At this point, the "INK ON" LED will flash once, while the "STATUS" LED will stay on. Proceed to **Section 4 “System Operation”** for ink cartridge installation, inker setup, alignment and controller operation instructions.

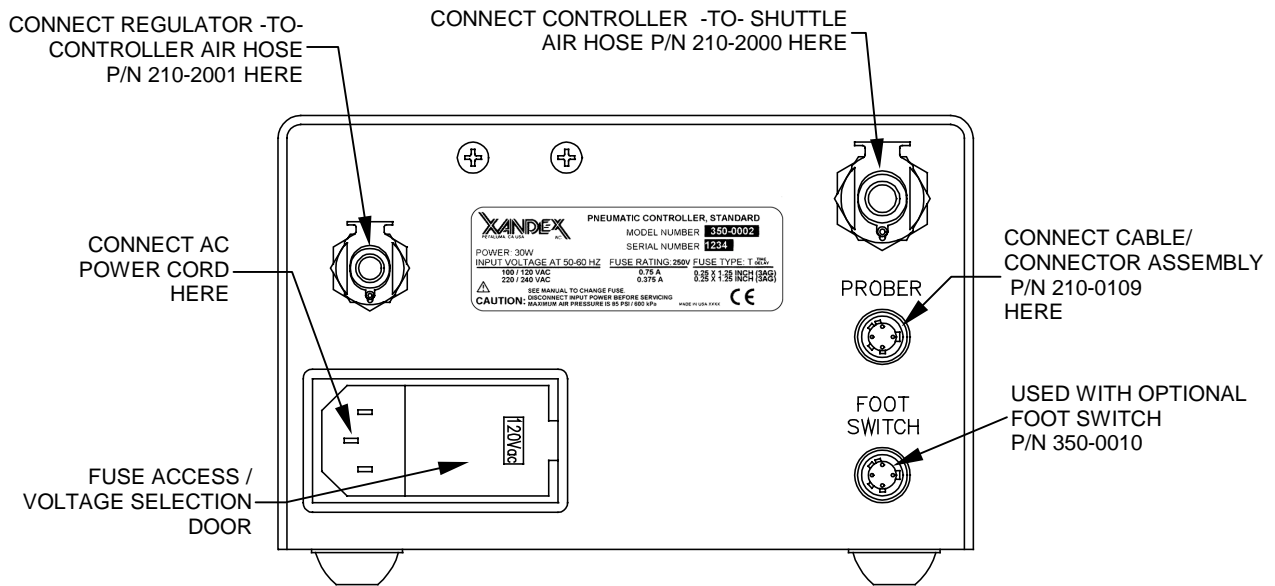

Voltage Selection & Fuse Replacement

*Note: This unit is shipped with the voltage set for 120VAC. Two fuse types are included, one for 100/120VAC and one for 220/240VAC, however, **the controller unit is shipped without a fuse installed**. Select the correct fuse for your voltage rating from the chart below and install per instructions. Discard unused fuse.*

1. Disconnect power cord from rear of controller (if connected).

Note: There is no power switch on this unit. If the unit loses power, memory of any hour or dot count programmed into the unit will be lost.

2. Swing open the fuse cover door by lifting on tab on the right side of the door. (A small screwdriver may be necessary.)

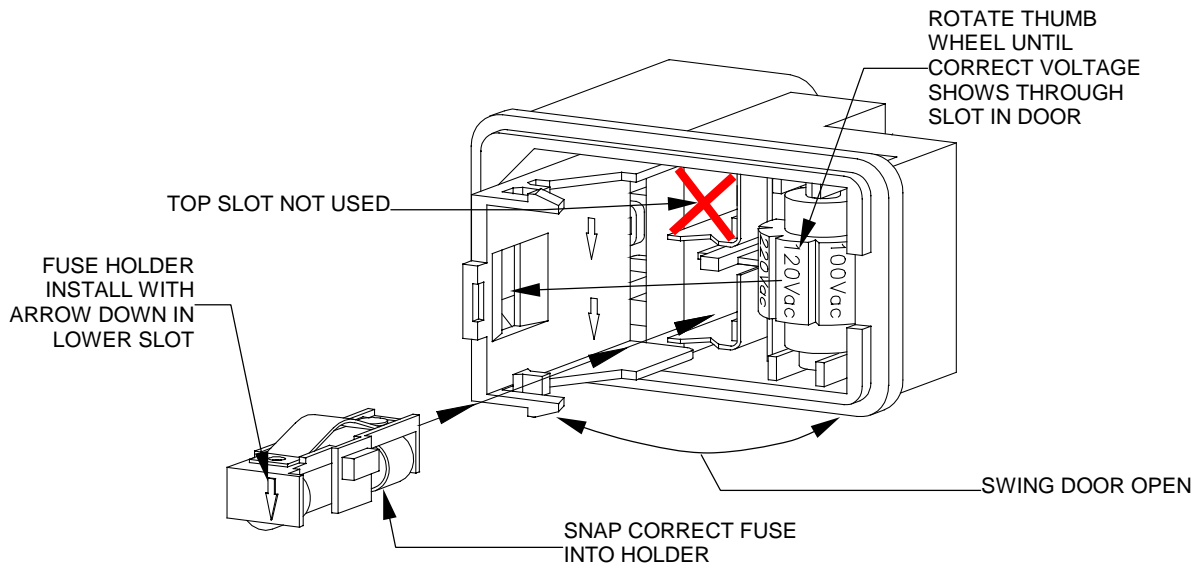

3. To change voltage setting, rotate the thumbwheel until correct voltage listed on the thumbwheel is facing out (visible through the slot in the door when the door is closed.)
4. To change the fuse, remove the fuse holder from the module by pulling it straight out. Carefully pry the fuse from the holder and replace (see fuse rating chart below.)
5. Insert the fuse holder into the **bottom** (lower) slot in the module with the arrow on the fuse holder pointed down.
6. CAREFULLY close fuse cover door. Verify that the correct voltage shows through the window on the module door. Reconnect power cord and verify controller power.

Note: Xandex supplied fuses match the ratings listed in the chart below.

INPUT VOLTAGE AT 50-60HZ	FUSE RATING; 250 V	FUSE TYPE: T or Time Delay	XANDEX PART NUMBER
100/120VAC	0.75A	3AG (0.25" x 1.25")	158-0032
220/240VAC	0.375A	3AG (0.25" x 1.25")	158-0479

Section 4. System Operation

Controller Operation

Programmable Thumbwheel Counter

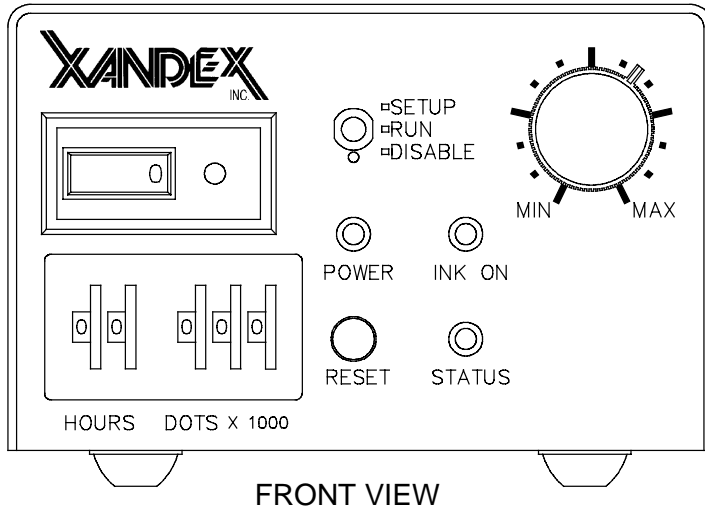

Individual thumbwheel settings are available to monitor either the number of dots, the number of hours of operation, or both. The first two thumbwheels on the left are for monitoring the number of hours, with a maximum setting of 99 hours. The next three thumbwheels are for monitoring the number of dots produced, with a maximum setting of 999,999 dots. A red "STATUS" LED will be illuminated when either of the programmed limits are exceeded.

To set the limits for hours only, set the Hours thumbwheels for the desired value and the Dots thumbwheels for 000. To set the limits for the number of dots only, set the Dots thumbwheels for the desired value and the Hours thumbwheels for 00. To use both limits, set each thumbwheel for the desired values. Both settings are monitored and stored in RAM in the microprocessor and are not battery backed-up.

HOURS	DOTS X 1000	REACTION
Set	000	"STATUS" LED is lit when "HOURS" set point is reached. For example, if you set the "HOURS" thumbwheel to 24, the "STATUS" LED will turn on when 24 hours of operation are complete.
00	Set	"STATUS" LED is lit when dot count set point is reached. For example, if you select 30,000 dots (turning the "DOTS X 1000" thumbwheel to 30) the "STATUS" LED will light when 30,000 dots have been deposited.
Set	Set	"STATUS" LED is lit when 1st set point is reached, regardless if it is hours or dot count.
00	000	"STATUS" LED will not light up (inactive). Feature not invoked.



CAUTION: The programmed set points (number of dots or hours) and their associated counters are stored in volatile memory (RAM). If power is lost, the set points will be lost and must be re-programmed using the RESET button.

Mode Selection Switch

A three position toggle switch is located on the front panel for selecting different operating modes.

- SETUP = Shuttle air valve (V2) is enabled
- RUN = Normal operation
- DISABLE = Shuttle air valve (V2) is disabled

When placed in the "SET-UP" position, the shuttle air valve (V2) is enabled, moving the shuttle to its lowest position for Z set-up adjustment. While in the "SET-UP" mode, perform coarse Z height adjustment as described in the Set-Up and Alignment procedure later in this section (4).

After five minutes in the "SET-UP" mode, the microprocessor will disable the shuttle air valve, returning the shuttle to the normal position. This is to prevent damage to the valve caused by extended operation. If set-up was not completed, return the switch to the "RUN" position, then back to "SET-UP". In the "RUN" position, the system operates normally. When the toggle switch is placed in the "DISABLE" position, the shuttle air valve (V2) is disabled and the shuttle does not extend during inking. This mode is used in hand-inking applications with the optional foot switch.

Reset Button:

A "RESET" button is located to the right of the thumbwheels for resetting the counters in the microprocessor. When the "RESET" button is depressed once, the "STATUS" LED will flash for 5 seconds. If it is pressed a second time during this period, it will "read" the setting on the thumbwheel switches and load those values into the microprocessor. If the "RESET" button is not pressed a second time and the 5 second flash time is exceeded, the "STATUS" LED will stop flashing and the current timer set points and internal counts will not be changed. The "RESET" button is also used to enter the diagnostic mode when power is applied to the controller with the "RESET" button depressed. For details and descriptions of controller diagnostic tests see **“Controller Diagnostics”** in **Section 6**.

***Note:** If the prober is running and the "RESET" button is pushed, the LED will flash intermittently. After 5 seconds, the "STATUS" LED will stop flashing and the unit will continue with the current programming. If the prober is running and the reset button is depressed a second time, INPUT SIGNALS FROM THE PROBER WILL BE INHIBITED AND THE UNIT WILL RESET AND RE-PROGRAM ITSELF.*

Dot Counter:

A separate LCD "DOT COUNTER" is located on the front panel above the thumbwheels. The LCD "DOT COUNTER" gives a real time read out of the number of dots deposited. The counter has an internal Lithium battery with a nominal life of 10 years, and an integral reset button. Pressing the small red reset button next to the "DOT COUNTER" LCD window will reset the counter display only. It will have no effect on the programmed counter circuits within the microprocessor. The counter should be reset when a new ink cartridge is installed to accurately record the numbers of dots produced by that cartridge.

Adjustable Dot Size

The adjustable "DOT SIZE KNOB" on the front panel is used to vary the size of the dot produced without changing cartridges, affecting set-up or requiring additional operator steps. The microprocessor reads the knob position and outputs a signal to enable the associated air valve for a predetermined amount of time. The higher the setting, the longer the valve is enabled, producing a larger dot.

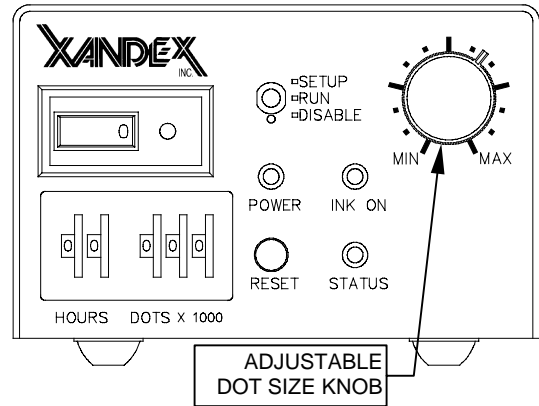

Depending on the type of ink cartridge (A5, A6, or A8) and ink used (6990, 6993, 6997, 7824, 7824T, 8103 or 8104), a 14 mil to 86 mil dot is possible. It is recommended that the proper dot size for the die be selected to maximize the cartridge usage and minimize problems with too large or too small dots.

DOT SIZE PARAMETERS								
DM-2 CARTRIDGE	INK TYPE 6990--6993--6997		INK TYPE 7824, 7824-T		INK TYPE 8103		INK TYPE 8104	
	Min	Max	Min	Max	Min	Max	Min	Max
36" AIR HOSE								
A5	15 mil	29 mil	17 mil	23 mil	14 mil	23 mil	26 mil	48 mil
A6	19 mil	33 mil	24 mil	28 mil	18 mil	28 mil	37 mil	60 mil
A8	32 mil	52 mil	31 mil	41 mil	26 mil	41 mil	56 mil	86 mil

Note: Characterization testing performed at ambient temperature of 70 degrees F, relative humidity of 50% on polished, unetched silicon wafers (no passivation). Air pressure 70 PSI, at minimum and maximum controller settings. Dot size varies depending on passivation type and air pressure setting.

External Switch Input

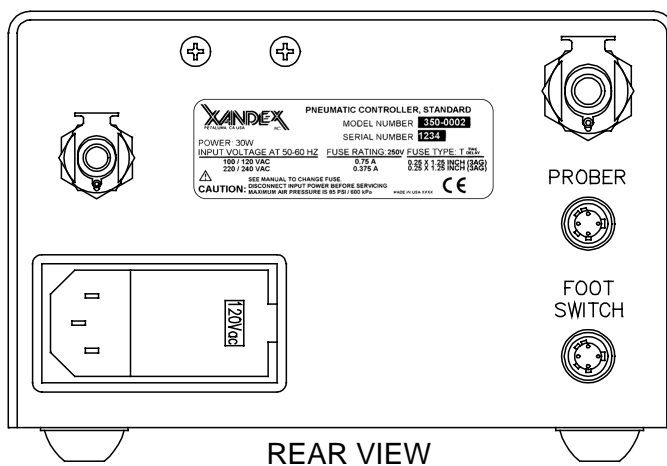

There is a second input on the rear of the unit for use with a foot switch. Upon activation, the foot switch sends a > 50 mSec switch closure signal (across pins 2&4) to the controller, enabling an inking sequence. There is a 50-millisecond delay between the end of the sequence and the recognition of the next switch closure. No other adjustments or settings need to be made.

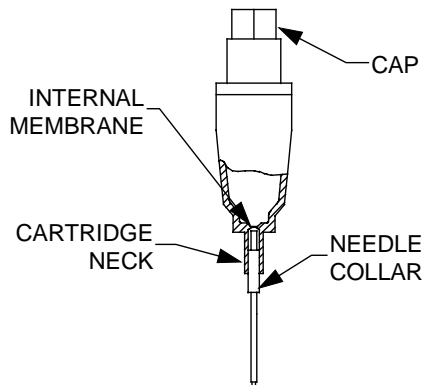
Ink Cartridge

The ink cartridge used with the X6110 Pneumatic Inker is a DM-2, which is available in A5, A6, and A8 types (designating 0.005", 0.006", and 0.008" Teflon® tube I.D., respectively). DM-2 cartridges have a polypropylene reservoir (sealed at the bottom by a thin membrane) and a small Teflon® tube encased in a stainless steel needle. When the cartridge is opened, the needle punctures the membrane to provide ink flow through the Teflon® tube.

Each cartridge holds approximately 1.0 grams of ink, (\pm 0.050 grams) and can produce a wide range of dots. The dot size is controlled by changing the duration of the air pulse into the cartridge reservoir, which determines how much ink is forced through the Teflon® tube and the size of the drop. The A5 and A6 cartridges will produce a minimum of 30,000 dots* consistently, while the A8 is rated at 10,000 dots*. For more information see **Section 5 "Ink"** and "Ink Cartridge Specifications" in **Section 8 "System Specifications."**

**Cartridge production figures are based on complete use within cartridge open shelf life periods of 5 days maximum or 3 days maximum, depending on the ink type.*

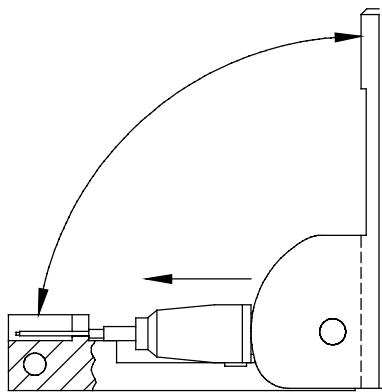
Cartridge Preparation

1. Place the cartridge into the cartridge preparation tool (Xandex Part No. 200-0001) as shown, exercising care to avoid damaging the Teflon® tip. The cartridge cap should be seated in the tool hinge with the needle resting in the slot.
2. Firmly squeeze the tool fully closed with a smooth, quick motion. This will push the cartridge body forward, causing the needle to puncture the internal membrane.

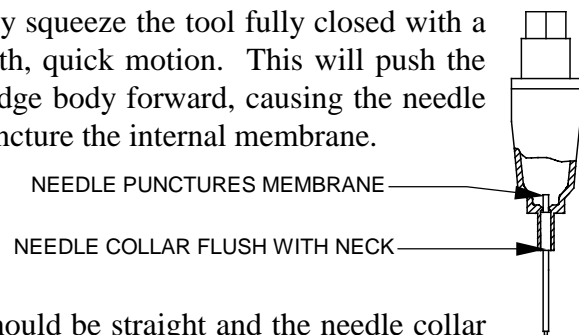

3. Open tool and remove cartridge. The needle should be straight and the needle collar flush with the cartridge neck.



CAUTION: Do not shake the cartridge at any time, as air bubbles may be introduced into the reservoir and restrict the flow of ink. If mixing of the ink in the reservoir is desired, roll the cartridge between thumb and forefinger (or between palms) for 1-2 minutes prior to installation.

Cartridge Installation



CAUTION: Raise the inker to maximum Z height by turning the Z adjust knob clockwise when installing or changing cartridges to prevent damaging the cartridge tip.

1. Use the slotted section of the cartridge preparation tool and a *counter-clockwise* motion to remove cap.

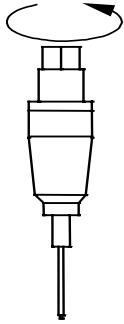

2. Thread the cartridge onto the brass air fitting of the RED AIR HOSE, turning the cartridge *clockwise* until snug.

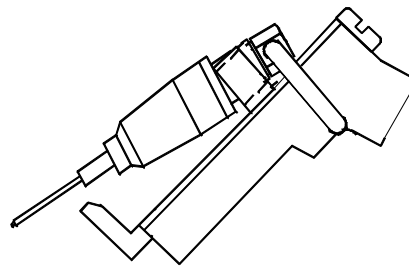
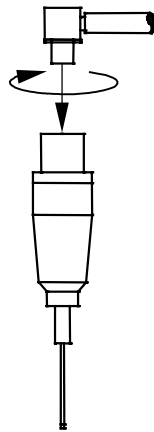

3. Press top of cartridge into shuttle spring clip.

4. Press cartridge body into shuttle forks until the neck fully snaps into place.

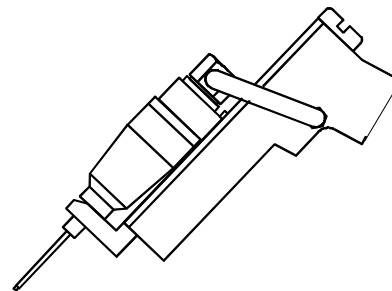

Cartridge is now ready for priming. (See “**Cartridge Priming**” later in this Section (4) for instructions)

Changing the Cartridge

1. Raise the inker to maximum Z height position.
2. Place thumb and forefinger on each side of the cartridge and gently pull out to remove cartridge.
3. Unthread the cartridge from the air fitting and discard in the proper manner.
4. Inspect the air fitting and air hose for ink contamination and clean or replace as necessary.
5. Install a new cartridge per installation instructions.

Cartridge Priming

CAUTION: Always wear protective eyeglasses when handling an active pneumatic inking system!

1. Prepare a cartridge per the “Cartridge Preparation” section of this manual.
2. Install a cartridge to the inker per the “Cartridge Installation” section of this manual.
3. Move the controller switch to “RUN”.
4. Push the “RESET” button on the controller for at least 3 seconds and hold down until ink appears at the needle tip.

Note: When the “RESET” button is initially pushed the “INK ON” LED will not be lit and the “STATUS” LED will begin to flash. At the end of 3 seconds both the “INK ON” and “STATUS” LED will light continuously and the air valve will begin to pulse, priming the cartridge.

5. Once priming is completed, clean excess ink from the needle tip with a lint free cloth.
6. Cartridge is now ready for operation. Proceed to “**Inker Assembly Setup and Alignment**” in this section (4) to prepare inker.

Note: Always use the RESET button to pulse the cartridge valve when priming a cartridge. The RESET button fires **only** the inker's cartridge valve.

Ink Cartridge Labeling

DieMark ink cartridges are individually labeled with two distinct labels. One label shows the cartridge type and the other label indicates the ink batch number, ink type and expiration date of the cartridge.

Do not remove the labels from the cartridges as this can cause cartridge type and ink types to be confused at cartridge installation, resulting in improper performance. Removal of cartridge labels will also void the cartridge warranty.

DieMark Cartridge Type Label

This label contains the cartridge type, (either **A5**, **A6** or **A8**).

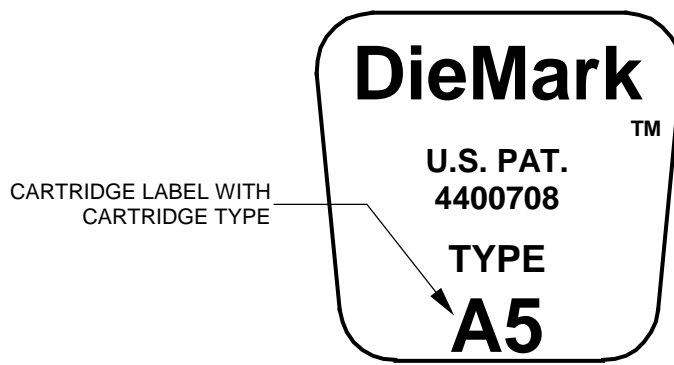

DieMark Cartridge Expiration Date Label

This label indicates the ink type and batch number of the ink contained in the cartridge and the cartridge expiration date. Expiration dates shown are for *unopened* cartridges.

- ◆ Markem[®] 6990, 6993, 6997 and Xandex 8103, 8104 = Four (4) months.
- ◆ Xandex 7824 and 7824T = Two (2) months.

After the cartridge is opened, consistent ink flow can only be expected for up to five (5) days for Markem[®] 6990, 6993, 6997 and three (3) days for Xandex 7824, 7824T, 8103 and 8104.

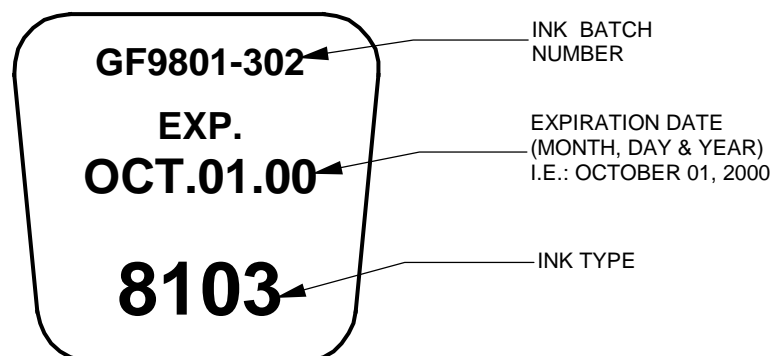

Inker Assembly Setup & Alignment

1. Prepare, prime and install an ink cartridge per the instructions in this Section (4).
2. Once priming is completed, verify that the inker is at maximum Z height (CW) position. Z axis adjustment range is approximately ± 0.29 ".
3. Set the prober chuck "Z Up".



CAUTION: *If the inker height is adjusted with the prober stage "Z Down," the cartridge will be positioned too low and the cartridge needle will smash into the wafer when you begin inking. This will stop the ink flow and possibly ruin the cartridge or damage the wafer!*

4. Use the X and Y adjustment knobs to position the cartridge tip over the desired die location. Adjustment range is approximately ± 0.34 " for each axis.

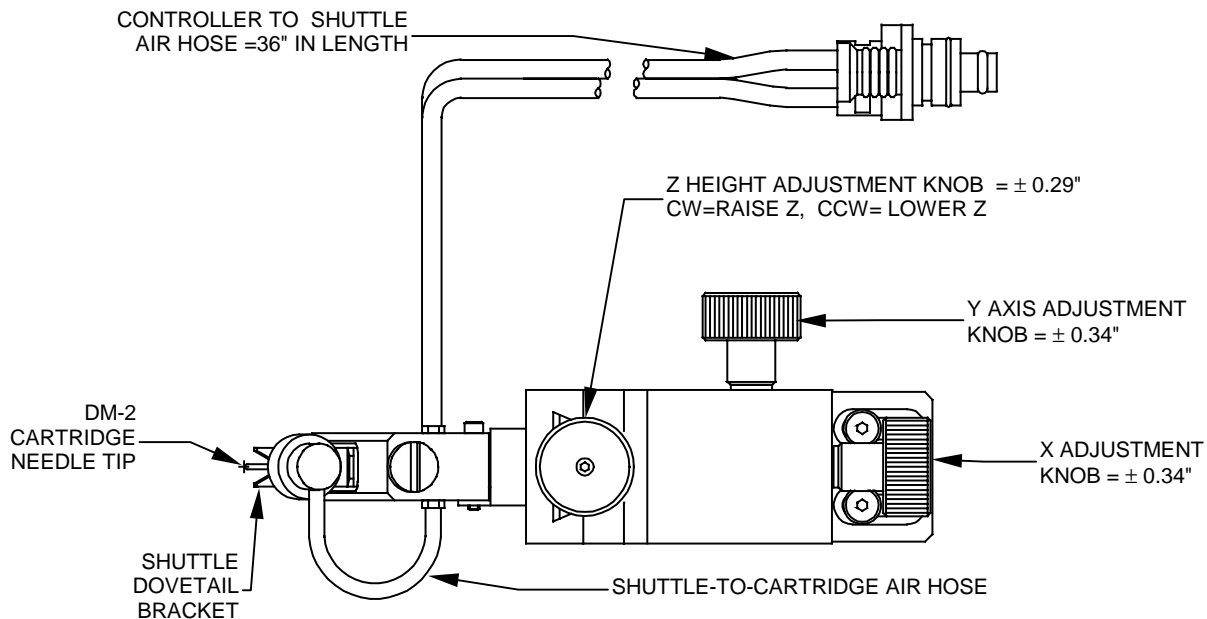

5. Set the controller "DOT SIZE" adjustment knob to the middle of the adjustment range. Move the locking toggle switch to "SETUP". The "INK ON" LED will flash continuously and the shuttle will extend to its lowest position. Create a droplet of ink at the needle tip by pressing the prober "TEST INKER" button twice.

Note: *The Controller can remain in the "SETUP" mode for a maximum of 5 minutes. After 5 minutes, the Controller will disable the shuttle air valve, returning the shuttle to normal position (the inker will fire, but the shuttle will not move) preventing damage to the valve caused by extended operation. If this happens, move the toggle switch to "RUN" then back to "SETUP" to complete alignment.*

- Slowly turn the *Z Adjust knob* counterclockwise to lower the *shuttle* until the ink droplet at the *needle tip* touches the wafer surface. The Teflon® tube will be 1-2 mil from the wafer surface.

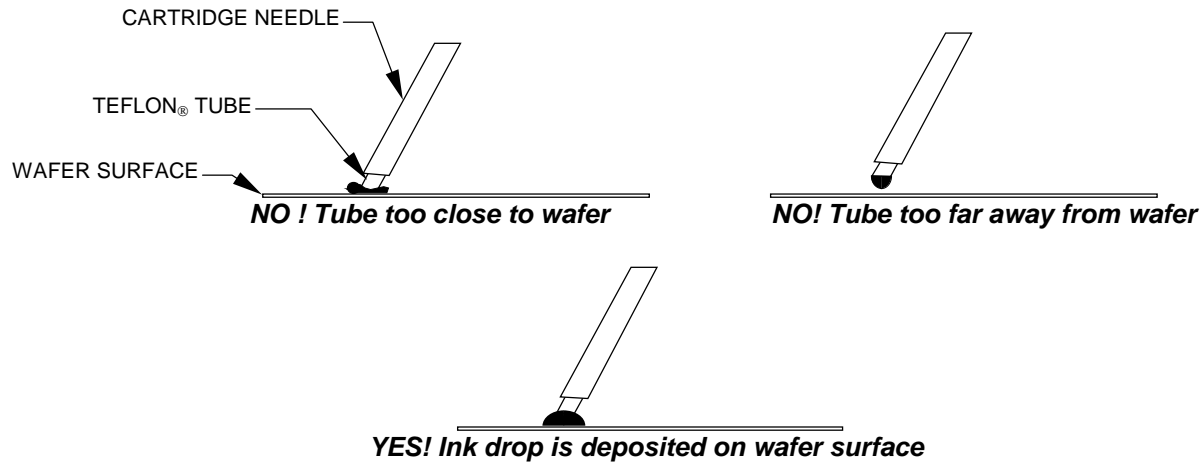

CAUTION: Do not let the Teflon® cartridge tube contact the wafer surface. This may crush the tip preventing ink flow and damaging the cartridge!

- Set the toggle switch to "RUN" to retract the shuttle. Index and test fire the inker a few times and check the dots for size and roundness. Each time the inker fires, the "INK ON" LED flashes.
- Perform minor X,Y and Z adjustments as necessary for dot placement and adjust the "DOT SIZE" knob until the desired dot size is achieved.
- After initial set-up is completed, some additional adjustment of the Z height may be required to achieve round dots. If you have problems, refer to **Section 6 "Maintenance & Troubleshooting."**

This page is intentionally left blank.

Section 6. Maintenance & Troubleshooting

This Troubleshooting section for the X6110 Pneumatic Inker is divided into three parts. The first part covers ink and the DM-2 ink cartridge. The second part covers the Inker Assembly, and the third part covers the Pneumatic Controller.

Ink Troubleshooting

Problem	Solution
Some ink dots tend to crack after baking using Xandex recommended cure cycles.	This occurrence is related to the ink surface tension, the wafer surface conditions and too long a delay time between inking and curing. To remedy this situation, the curing cycle has to be modified (reduce time and temperature). See Section 5 “Ink Curing.”
Runny, blobbing ink or skipping dots.	<ol style="list-style-type: none"> 1. Check ink shelf life. Markem[®] 6990, 6993, 6997 inks should be used within 4 months or 5 days of cartridge opening. Xandex 8103 and 8104 air dry glycol free inks should be used within 4 months or 3 days of cartridge opening. Xandex 7824 and Xandex 7824T air-dry ink within 2 months or 3 days after cartridge opening. 2. Check for exposure to extreme temperatures. Cartridges should be stored at 25°C. DO NOT refrigerate the cartridges. Occasionally, ink is subjected to much higher temperatures (40-50° C) for an extended time during transport. This could break down the ink such that its viscosity and surface tension are altered permanently. Contact Xandex Customer Service. 3. Improper Z Height set-up. Review proper procedures detailed in Section 4 “Cartridge Setup and Alignment” and re-adjust inker Z Height. 4. Chuck top or wafer surface not planar. Verify planarity of both.
After changing the controller dot size settings, the dots are too small or the ink blobs at the tip of the needle.	<ol style="list-style-type: none"> 1. The cartridge tip may be damaged. Examine cartridge and replace if necessary. 2. Whenever dot size is changed there may be minor Z height adjustments required. The inker should be set so that just the bottom of the ink drop touches the wafer.

Problem	Solution
Small, inconsistent or no ink dots.	<ol style="list-style-type: none">1. Soft Teflon® tip of the cartridge tube is clogged or damaged. Change cartridge.2. The dot size setting may be too low. Increase dot size setting.3. Wrong cartridge type. Change cartridge type.4. Air pressure too low, verify setting is 70 ± 10 PSI.5. Z height adjustment is incorrect. Adjust Z Height. See Section 4 “System Operation.”6. Verify that the mounting screws are not loose and that the inker is flush against the insert ring.7. Shuttle mechanism may be binding. See “Shuttle Maintenance” in this section.

Inker Assembly Troubleshooting

Problem	Solution
Dots too large.	<ol style="list-style-type: none"> 1. Dot size setting too high. Decrease dot size setting. 2. Main Air pressure too high, verify setting at 70 ± 10 PSI. 3. Wrong cartridge type. Change cartridge type. 4. Dot size potentiometer defective. Run diagnostic test B, described in “Controller Diagnostics” later in this section (6). If test results are not within parameters, consult Xandex Customer Service.
Cartridge tip does not reach wafer surface.	<ol style="list-style-type: none"> 1. Check Z height by switching the controller into "SETUP" mode, which will extend the shuttle downward into the "inking position". 2. Adjust Z height per "Setup and Alignment" in Section 4 “System Operation” of this manual.
Unit functions normally, no dots, no shuttle movement.	<ol style="list-style-type: none"> 1. Verify that the Controller-shuttle air hose connector is plugged into the controller. 2. Verify that the Controller-shuttle air hose is not kinked, clogged or pinched closed. 3. Check Main Air pressure setting (verify 70 ± 10 PSI air input).
Unit functions normally, shuttle moves, no dots.	<ol style="list-style-type: none"> 1. Check air hose to top of cartridge to be sure it is connected and not kinked, clogged or pinched. 2. Verify cartridge preparation, insuring Needle Collar is flush with the Cartridge Neck and the internal membrane is broken. See Section 4 “Ink Cartridge.” 3. Check the Teflon[®] tip of cartridge tube to confirm that it is not clogged or damaged. 4. Verify that the rubber washer on the cartridge air hose connector is installed.

Problem	Solution
Inker produces dots during “puff pulse” or ink flows out of cartridge with toggle switch in “SETUP”.	<ol style="list-style-type: none"><li data-bbox="646 233 1422 646">1. Verify that the air hoses from the controller to the inker are connected properly:<ul style="list-style-type: none"><li data-bbox="737 348 1422 422">◆ SHORT RED AIR HOSE connects to the ink cartridge.<li data-bbox="737 464 1422 537">◆ BLUE AIR HOSE connects to the TOP barbed fitting on the shuttle mechanism.<li data-bbox="737 579 1422 653">◆ RED AIR HOSE connects to the BOTTOM barbed fitting on the shuttle mechanism.

Shuttle Maintenance Schedule

Periodic preventive maintenance of the shuttle mechanism is recommended to insure continued, trouble free operation of your Xandex pneumatic inking system. The recommended maintenance schedule is as follows;

- Off-line use = 6 month intervals
- In-Line / Post Probe use = Once per year

Shuttle preventive maintenance kits are available, which include all parts necessary for one normal shuttle maintenance procedure. These kits may be ordered direct from Xandex or through your local Xandex distributor. The X6110 inker requires kit number 370-0002. The following describes the procedure for disassembly and re-assembly of the Pneumatic Shuttle for maintenance purposes. Reference Drawing 316-0001 in **Appendix B** for part identification and associated part numbers.

Shuttle Removal

1. Remove the ink cartridge (if installed). See **Section 4 “Changing the Cartridge.”**
2. Disconnect the *twin pneumatic hose* at the shuttle connections (grasp, do not crush, the air hose with needle nose pliers over the fitting point and pull gently to disconnect, being careful not to damage hose).
3. Remove the two Allen screws securing the *shuttle assembly* to the *manipulator base* and remove the shuttle assembly for maintenance.

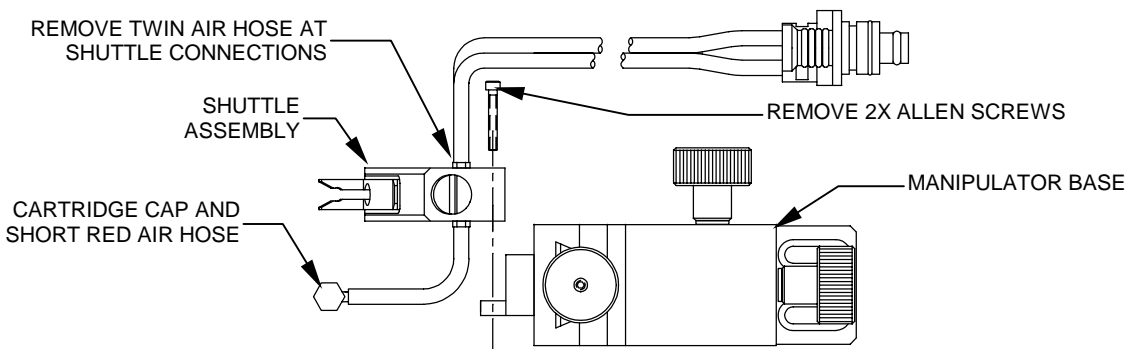

Shuttle Disassembly

1. Loosen the Allen Screw (Item 6) at the rear of the *shuttle assembly*, then unscrew the *cylinder/adaptor assembly* (Items 3 & 4) from the *shuttle assembly* and remove.
2. Carefully lift and remove the *pneumatic holder* (Item 2) from the *pneumatic holder bracket* (Item 1), paying close attention to the *spring* (Item 9) located in the bottom of the *pneumatic holder* (Item 2).

Shuttle Maintenance

With the Shuttle removed and disassembled, perform the following checks to verify condition/operation.

1. Connect a 1/8" pneumatic hose to each of the barbed *air hose fittings* (Item 5) on the *pneumatic holder bracket* (Item 1) and apply 40-80 PSI. Verify that there are no obstructions in the *pneumatic holder bracket* (Item 1) affecting the air signal.
2. Inspect the *pneumatic holder* (Item 2), *pneumatic holder bracket* (Item 1) and *spring clip* (Item 7) for wear or physical deformation. Replace as necessary.
3. Inspect the *cylinder/adaptor assembly* (Items 3 & 4). Remove and replace the two *O-rings* (Item 18). A lubricant (Parker O-lube or equivalent) applied to each *O-ring* prior to re-assembly will ease installation.
4. Install the *cylinder/adaptor assembly* (Items 3 & 4) in the *pneumatic holder bracket* (Item 1) and apply/remove 40-80 PSI air signal a few times. Verify that the shaft of the cylinder extends and retracts properly without hesitation or binding.
5. Remove the *cylinder/adaptor assembly* (Items 3 & 4) from *pneumatic holder bracket* (Item 1). If problems were noted in operation (air leak, cylinder sticking, etc.), separate the *cylinder* (Item 4) from the *adapter* (Item 3) and replace as necessary. Use pipe sealant (Loctite 567 or equivalent) or Teflon® tape on the *cylinder* (Item 4) threads to insure proper seal.
6. Inspect the *spring* (Item 9) for fatigue or physical deformation. Free length of the *spring* is 0.250" nominal. Replace as needed.
7. Remove the nylon tipped *Allen screw* (Item 6) that locks the *cylinder/adaptor assembly* (Items 3 & 4) in place in the *pneumatic holder bracket* (Item 1) and replace with a new screw.
8. Inspect the *cartridge fitting* and *short red air hose* for ink contamination. Clean fitting as necessary and replace the *washer*, on the *cartridge fitting*. Replace the *short red air hose* if necessary.

Shuttle Assembly

1. Apply lubrication (Item 17, MagnaLube-G, supplied with maintenance kit) to the *pneumatic holder* (Item 2) and *pneumatic holder bracket* (Item 1) as detailed in Note 4. on drawing 316-0001 in **Appendix B**.

2. Install the *spring* (Item 9) in the bottom of the *pneumatic holder* (Item 2), then carefully install the *pneumatic holder* (Item 2) in the *pneumatic holder bracket* (Item 1). Verify that the *spring* (Item 9) is in the proper position and the *pneumatic holder* (Item 2) moves freely in the *pneumatic holder bracket* (Item 1).

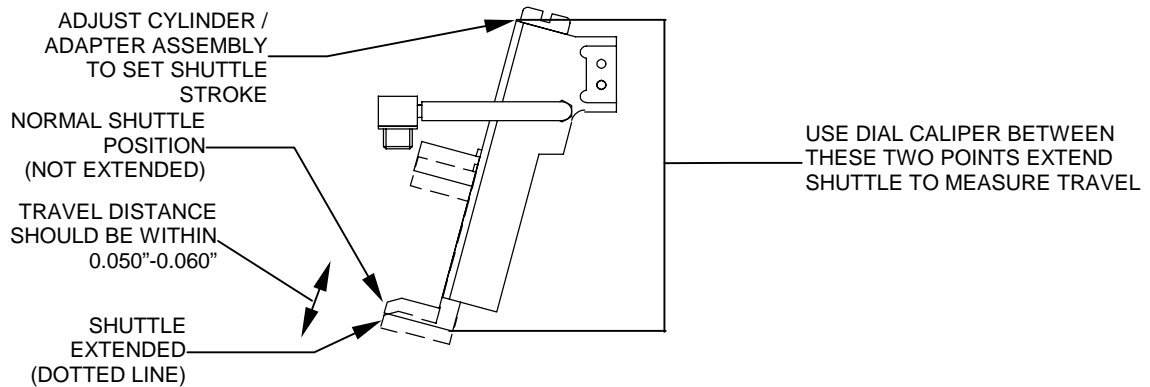

3. Install the *cylinder/adapter assembly* (Items 3 & 4) into the *pneumatic holder bracket* (Item 1), turning the *adapter* (Item 3) screw a maximum of 6 turns. Using a Dial Caliper, measure the stroke of the *pneumatic holder* (Item 2) from normal to extended position. Adjust the *adapter* (Item 3) screw until the stroke is between 0.050" and 0.060".
4. Tighten the *Allen screw* (Item 6) in the *pneumatic holder bracket* (Item 1) to lock down the *cylinder/adapter assembly* (Items 3 & 4). Apply 40-80 PSI air signal to the lower pneumatic connection on *shuttle assembly* and verify operation of *shuttle*.
5. Re-install the *shuttle assembly* on the *manipulator base* using the two *Allen screws* previously removed. Reconnect the *twin pneumatic hose* to the shuttle assembly. The red side of the twin air hose connects to the bottom barbed air fitting on the shuttle. The blue side connects to the top fitting. Install a cartridge, and test to verify operation.

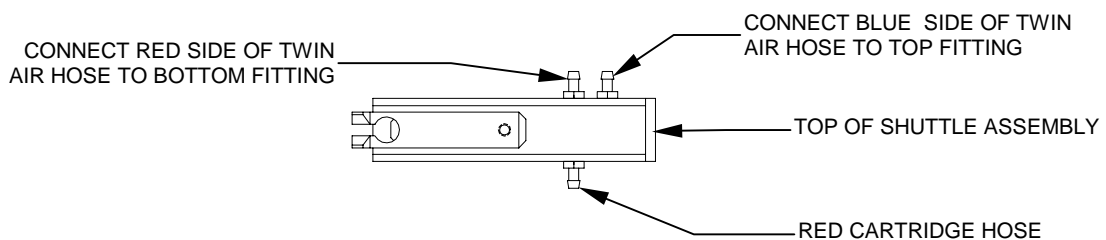

Controller Maintenance and Diagnostics**Controller Sequence of Operation**

To initiate an ink dot, the Prober sends a 12-60 V (AC/DC unregulated) active-low signal to the Controller. After receipt of the signal, the microcontroller performs various checks of system status prior to firing the pneumatic valves.

Upon completion of the status checks, a 22.47ms pulse is sent to the Shuttle Valve (V2), while at the same time a 6.4-24.8ms pulse (depending on position of Dot Size knob) is sent to the Cartridge Valve (V1).

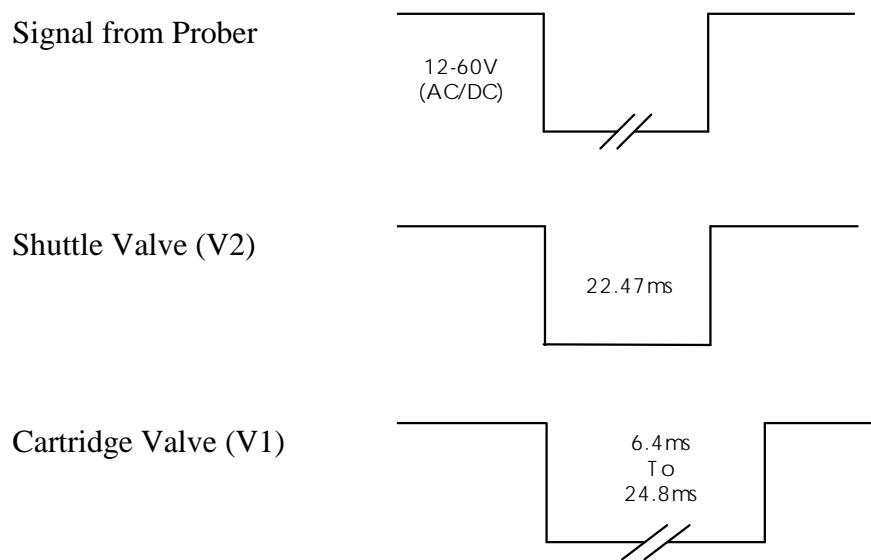

As the shuttle extends to the lower position, the air pulse from Valve 1 forces ink out of the cartridge barrel and forms a drop at the end of the needle tip. When the shuttle is at its lowest position, the drop makes contact with the wafer surface and forms a dot. The shuttle then returns to the normal position.

At the completion of each dot, a small amount of vacuum is developed in the cartridge by the closure of the valve, preventing dripping. If another dot sequence is not initiated within 10 seconds, a short “puff” pulse equal to 1/2 the dot size duration (10-20ms) is sent to the cartridge to displace a small amount of ink back into the Teflon® tube to aid in maintaining proper dot size after a long delay between dots.

Controller Diagnostics

There are a few internal diagnostic tests available for testing the Controller. To enter the Diagnostics mode, apply power to the Controller with the “RESET” button to the right of the thumbwheels depressed.

The following tests are available:

A. Test Thumbwheels

1. Place the toggle switch on the front panel to SET-UP, set the thumbwheels to 12345, then reset the LCD Counter.
2. Press the RESET button and verify that the counter increments 15 counts.
3. Place the toggle switch to RUN, set the thumbwheels to all 1's, reset the LCD Counter, and press RESET. The counter should increment one count.
4. Repeat the procedure for the rest of the digits (2 through 9). With the thumbwheels set for 00000, the counter increments 10 counts.

B. Test Dot Size Potentiometer

1. Place the toggle switch to DISABLE, set the HOURS thumbwheels to 01, then reset the LCD Counter.
2. With the Dot Size knob set at the minimum position, press the RESET button and verify that the LCD Counter does not increment.
3. Set the knob to 50% and press RESET. The Counter should display approximately 130 counts. (Variations in Dot Size knob alignment to scale may occur. An increment of ± 10 is not significant in this case.)
4. Reset the LCD Counter, adjust the knob to maximum, and press RESET. The Counter should display 255 counts.

C. Test Cartridge Valve

To test fire the Cartridge Valve 20 times:

1. Set the HOURS thumbwheels to 02
2. Place the toggle switch to DISABLE
3. Reset the LCD Counter
4. Press RESET.

The cartridge valve fires 20 times, each time incrementing the LCD Counter.

D. Test Shuttle Valve

To test fire the Shuttle Valve 20 times:

1. Set the HOURS thumbwheels to 03
2. Place the toggle switch to DISABLE
3. Reset the LCD Counter
4. Press RESET.

The shuttle valve fires 20 times, each time incrementing the LCD Counter.

E. Life Test

This test will continuously fire the Cartridge and Shuttle valves for a predetermined number of cycles as set on the thumbwheels.

1. Place the toggle switch to DISABLE.
2. Set the HOURS thumbwheels to 10.
3. Set the DOTS X1000 thumbwheels for the desired number of cycles X1000 (i.e.: 250 Equals 250,000 cycles).
4. Reset the LCD Counter.
5. Press RESET.

The Controller begins continuous firing, incrementing the Counter each cycle. To discontinue the Life Test prior to reaching the set amount, remove power.

Controller Troubleshooting

Problem	Solution
The Unit is plugged in but the "POWER" LED is off.	Make sure that the outlet has power. The requirement is 100/120/220/240 volts. Check controller fuse to be sure it is still good. See Section 3 "Fuse Replacement."
Unit powers up okay but will not respond to prober signal.	<ol style="list-style-type: none"> 1. Verify input cable is plugged into the proper input on the Controller. 2. Verify input cable is plugged into inker jack on prober. 3. Check continuity of cable. 4. Perform system diagnostics checks to verify Controller operation. See Section 6 "Controller Diagnostics."
Unit powers up okay, responds to prober input but the shuttle does not move.	<ol style="list-style-type: none"> 1. Check that shuttle toggle switch on the front of the controller is in the RUN position. 2. Check that the air hose "quick disconnects" are correctly oriented. 3. Perform Shuttle Valve diagnostic test to verify operation. See Section 6 "Controller Diagnostics."
Dot size does not change with adjustment of Dot Size Knob	<ol style="list-style-type: none"> 1. Verify that the air hoses from the controller to the inker are connected properly: <ul style="list-style-type: none"> ◆ BLUE AIR HOSE connects to the TOP barbed fitting on the shuttle mechanism. ◆ RED AIR HOSE connects to the BOTTOM barbed fitting on the shuttle mechanism. 2. Run diagnostic test "B." Dot Size Potentiometer Test described in "Controller Diagnostics" above in this section (6). If test results are not within parameters, consult Xandex Customer Service. 3. Wrong ink cartridge type. Replace ink cartridge with larger (or smaller) type dot size rating. See "Dot Size Parameters" table in Section 4. "Operation."

Controller Internal Maintenance**Controller Logic Board Removal**

CAUTION: Use appropriate ESD precautions when working inside of the controller!

With Power and Main Air removed:

1. Remove the cover of the *controller*.
2. Disconnect the *connectors* from J2-J5 on the *controller logic board*. (See wiring diagram 260-0019 in **Appendix B**)
3. Push back both locking devices on the card guides to unlock position, then lift the *logic board* from the mounting location.
4. Disconnect *connector* from J1 on the *logic board*.
5. Place the *logic board* on ESD protective surface or store in ESD protective anti-static bag.

Reverse this procedure for installation of *logic board*.

Removal/Replacement of Microcontroller**With the Logic Board removed:**

1. Carefully remove the Motorola 68705R3 *microcontroller* from the socket (U7) using the appropriate IC removal tool or flat blade screwdriver. Reference Drawing 250-1001 in **Appendix B**.
2. *Use caution when removing the Microcontroller to prevent damage to the leads.*
3. Place the *microcontroller* on anti-static foam, then in ESD protective anti-static bag for storage.

To re-install:

1. Match pin one markings on *microcontroller* and *logic board*, line up component leads with socket (verify correct orientation of *microcontroller* per Drawing 250-1001 in **Appendix B**) and gently press to install, using caution to prevent bending or damage to the leads.
2. Visually inspect the socket and *microcontroller* to insure the integrity of the installation prior to re-installation of *logic board*.

3. After installing the *microcontroller*, re-install the *logic board* by reversing the procedure outlined in the “Controller Logic Board Removal” above.
4. Install the cover, apply power and main air, and test to verify operation. If problems are noted, review the installation of the *microcontroller* to insure none of the component leads are bent, and verify connection of J1 through J5 connectors on the *logic board*.

Pneumatic Controller Preventive Maintenance Schedule

The two solenoid driven air valves used in Xandex pneumatic controllers to drive the Pneumatic Shuttle and Ink Cartridge are identical. Valve one (V1) supplies air to the ink cartridge, and is also referred to as the Cartridge Valve. Valve two (V2) supplies air to the pneumatic shuttle and is also called the Shuttle Valve.

Xandex Auto Z and Motorized Z controllers contain a third valve (V3) that is identical to the Shuttle and Cartridge valves. The Auto Z controller uses this valve only when the Auto Z function is engaged. The Motorized Z uses this valve to change the air pressure supplied to the cartridge valve when inking in small dot mode. In normal operation, the third valve (V3) in either the Auto Z or Motorized Z controller will not need replacement for the life of the unit.

Preventive maintenance for Xandex pneumatic controllers requires replacement of just the Cartridge Valve, or of both the Cartridge and Shuttle valves at the intervals specified below.

Controller Model	Replace	Interval
All Models	Cartridge Valve	12 million cycles
All Models	Cartridge Valve, Shuttle Valve and internal tubing	Every 24 months

Two valve replacement kits are available from Xandex to facilitate controller preventive maintenance.

- Cartridge Valve Kit, containing a single valve assembly, electrical connectors and replacement instructions. This kit is used for the 12 million cycle controller preventive maintenance. Order part number 370-0100.
- Dual Valve Kit containing two valve assemblies, electrical connectors, adequate tubing to replace all internal controller pneumatic routes in all Xandex pneumatic controllers and replacement instructions. Replacement of the polyurethane tubing is recommended as the internal operating temperature within the controller enclosure can cause the tubing to shrink slightly over time. This can result in leaking connections at the valve and coupling connections. This kit is used for the 24 month controller preventive maintenance. Order part number 370-0101.

For more information or to order pneumatic controller PM kits, contact Xandex Customer Service at (707) 763-7799, (800) 767-9543 (toll free in the US), FAX (707) 763-2631; email info@xandex.com or order online at www.xandex.com.

Cartridge (V1) or Shuttle (V2) Valve Replacement

 *This procedure is to be used for replacement of either valve, as they are identical.*

Note: *Controller units manufactured before June, 1999 used a soldered wire splice covered by heat shrink tubing for valve electrical connections, instead of the snap plug connectors used in the current build. The replacement valve assembly P/N 240-0261 is shipped with post-end snap plug connectors. To order crimp on receptacle connectors to retrofit an older controller unit, contact Xandex Customer Service and order snap on receptacle connector P/N 519-0031. Four receptacle connectors are required for each controller (two per valve).*

With Power and Main Air removed:

1. Remove the four (4) cover screws from each side of the controller and remove the controller cover.
2. Disconnect the input and output pneumatic hoses from the defective valve by depressing the colored fitting collar and pulling on the pneumatic hose simultaneously.
3. Disconnect the two snap in connectors that connect the valve wires to the controller.
4. Remove the two Phillips mounting screws securing the valve to the Controller base and remove the valve.

Installation:

1. Install the replacement valve assembly (P/N 240-0261) in the *controller base*, securing with the two Phillips screws previously removed.
2. Connect the two snap in connectors on the valve wires to the receptacle connectors on the controller. Polarity does not matter.
3. Install the pneumatic lines accordingly, insuring that each hose is firmly seated in the valve fitting.
4. Apply power and main air.
5. Refer to “**Controller Diagnostics**” in this section and perform appropriate valve functional and diagnostic tests.
6. Re-install the controller cover.

Intentionally left blank.

Section 7. Software Options

Optional Software Programs

Optional software programs are available to modify the standard operation of the Controller. The options are:

- ◆ “No Puff” Kit Part Number 355-1024
- ◆ “HRS X 10” MCU Part Number 255-1019

The following describes each option:

“No Puff” Kit:

In normal operation, after completion of each dot a small amount of vacuum is developed in the cartridge due to the closure of the air valve in the Controller, causing the ink to back up into the cartridge reservoir, preventing dripping.

If another dot sequence is not initiated within 10 seconds, a “puff pulse” of air equal to 1/2 the dot size setting duration will displace a small amount of ink back into the Teflon tube to aid in maintaining proper dot size after long delays between dots. The 255-1024 Microcontroller contained in the kit removes the “puff pulse” from the normal operation.

“HRS X 10” MCU

In normal operation, the HOURS thumbwheels on the front of the Controller are used to set a limit for the number of hours of operation/use of each cartridge, with a maximum setting of 99 hours. Upon exceeding the limit, the red STATUS LED on the front of the Controller is illuminated.

Each time a new ink cartridge is installed, the RESET button is pressed twice to load the thumbwheel value into the Microcontroller. The 255-1019 Microcontroller changes the thumbwheel value to HRS X 10, for a maximum setting up to 990 hours of operation.

For installation procedures see **Section 6 “Controller Internal Maintenance”**, of this manual.

This page is intentionally left blank.

Section 8. System Specifications

Controller Specifications

Size:	6" x 6" x 4" (152mm x 152mm x 102mm)
Weight:	5.5 lbs (2.5 kg)
Power Requirement:	100/120/220/240 volts AC @ 50/60 Hz
Peak Power Consumption:	30W
Air Consumption:	70 PSI \pm 10 PSI Instrument Air per ISA 7.3 specification <0.5 cfm @ 750 cycles/minute
Cycle Rate:	Exceeds 750 cycles/minute
On-Time Range:	Cartridge Air Feed - Continuously Variable Pulse(Dot Size)(10-25 ms) Shuttle Air Feed - Fixed @ 22.5 ms
Control Circuits:	Motorola 68705 Microprocessor (On-Time Accurate to + 0.5%)
Shuttle Travel:	0.050" - 0.060" Fixed
Shuttle repeatability:	\pm .0005" (13 μ m)
Counters:	Six Digit with External Reset (Independent of Microprocessor)
External Regulator/Filter:	5.0 micron Air Filtration
Prober Input:	12 - 59 volts @ minimum 30 ms pulse width. Input circuit presents approximately 1 K Ω input resistance in parallel with a constant current source which sinks an additional 25 mA when input voltage exceeds the threshold voltage of approximately 15 volts. Typical current as a function of input voltage is listed in the following table:

10 V	10 mA
15 V	25 mA
20 V	45 mA
40 V	65 mA
59 V	85 mA (Maximum input)



On our sole responsibility we declare this product is in conformity to the following EU directives;

- EMC Directive 89 / 336 / EEC
- Low Voltage Directive 73 / 23 / EEC

Standards to which conformity is declared:

EN50081-2, EN50082-2, EN61010-1

- Environmental Range:
- Indoor use
 - Altitude up to 2,000 m
 - Temperature range 5° C to 40° C
 - Maximum relative humidity 80 % for temperatures up to 31°C decreasing linearly to 50 % relative humidity at 40 °C
 - Mains supply voltage fluctuations not to exceed ±10 % of the nominal values
 - Transient overvoltages according to INSTALLATION CATEGORY II
 - POLLUTION DEGREE 2

Ink Cartridge Specifications

Models:	DM-2, DM-2.3 / Type A5, A6, A8
Teflon Tube I.D.:	A5 - 0.005" / A6 - 0.006" / A8 - 0.008"
Reservoir Capacity:	1.0 grams (± 0.050 grams) nominal
Available Inks:	6990, 6993, 6997, 7824, 7824T, 8103, 8104
Dot Sizes:	Dot sizes (±10%) consistent for speeds of 12 dots/second to 1 dot/2 minutes

Seller warrants as follows:

All material supplied will conform to the description stated.

All products will be free of defects in materials and workmanship under normal use for the following periods:

Stated shelf life of DM-2 Ink Cartridges:

- ◆ Markem® 6990, 6993, 6997 = Four (4) months. Five (5) days after cartridge opening
- ◆ Xandex 8103 and 8104 = Four (4) months. Three (3) days after cartridge opening.
- ◆ Xandex 7824 and 7824T = Two (2) months. Three (3) days after cartridge opening.

Pneumatic Controller = One (1) year only when clean, dry, filtered air is used, and when product is installed and operated per manufacturer's recommendations and instructions.

Ninety (90) days from the date of delivery to the customer for all other products.

Xandex makes no other warranty, express or implied, including without limitation any warranty of merchantability or of fitness for a particular purpose. Customer, OEM or Distributor's exclusive warranty shall be, at Xandex's option, to have defective product repaired or replaced, or to receive a refund of purchase price.

Xandex may, upon request, furnish to buyer such technical advice, as it may be able to supply with reference to the use by buyer of any materials delivered. Xandex assumes no liability for the advice given or results obtained. Buyer expressly agrees that it will implement any advice thus given at its own risk and agrees to indemnify and hold Xandex harmless against any liabilities, costs or expense resulting therefrom.

Xandex makes no warranty for performance, service or support of any products purchased into the following territories unless purchased directly through a Xandex authorized Distributor: Austria, Belgium, Denmark, England, Finland, France, Germany, Ireland, Italy, Hong Kong, Japan, Korea, Malaysia, Netherlands, Norway, Philippines, Scotland, Singapore, Sweden, Switzerland, Taiwan, Thailand, and Wales.

Exclusions: This warranty shall not apply to defects or damage resulting from;

- Improper or inadequate maintenance by customer, including failure to perform preventive maintenance per manufacturer's specified schedule
- Misuse or unauthorized modification
- Operation outside the environmental specifications for the product
- Improper site preparation and maintenance

Some states and provinces do not allow limitations on how long an implied warranty lasts, so the limitation or exclusion contained in this warranty may not apply to you. However, any implied warranty of merchantability or fitness is limited to the duration period of this written warranty.

If you have any questions or need further assistance please contact your authorized Xandex distributor or contact our Customer Service Group.



Customer Service

1125 N. McDowell Blvd.

Petaluma, California 94954 U.S.A.

Toll Free in the United States (800) 767-9543

or (707) 763-7799 FAX (707) 763-2631

www.xandex.com

email; info@xandex.com

Description	Drawing Number
Inker Assembly, Model X6110	900-0185 1 of 2 2 of 2
Inker Kit X6110 (EG) Bill of Materials	340-6110 2 of 2
Inker Assembly, X6110	320-6110 1 of 2
Bill of Materials	2 of 2
Pneumatic Shuttle 36" Air Hose	316-0001 1 of 2
Bill of Materials	2 of 2
Pneumatic Controller Assy	350-0002 1 of 2
Bill of Materials	2 of 2
Pneumatic Controller Subassy.	260-0019 1 of 3 2 of 3
Bill of Materials	3 of 3
Controller Logic Board PC Assy	250-1001 1 of 1
Schematic, Inker	950-1001 1 of 1